

Environmental Impact Assessment for Wan Chai Development Phase II and Central-Wan Chai Bypass

Updated Environmental Monitoring and Audit Manual

For

- (i) Permanent and temporary reclamation works including associated dredging works in Wan Chai Development Phase II (WDII) area (referred to as “DP3” in the EIA report);
- (ii) Wan Chai East Sewage Outfall (referred to as “DP5” in the EIA Report); and
- (iii) Dredging for the Cross-harbour Water Mains from Wan Chai to Tsim Sha Tsui (referred to as “DP6” in the EIA Report)

under Environmental Permit No. EP-356/2009

(March 2011)



Environmental Impact Assessment for Wan Chai Development Phase II and Central-Wan Chai Bypass

Updated Environmental Monitoring and Audit Manual

For

- (iv) Permanent and temporary reclamation works including associated dredging works in Wan Chai Development Phase II (WDII) area (referred to as "DP3" in the EIA report);
- (v) Wan Chai East Sewage Outfall (referred to as "DP5" in the EIA Report); and
- (vi) Dredging for the Cross-harbour Water Mains from Wan Chai to Tsim Sha Tsui (referred to as "DP6" in the EIA Report)

under Environmental Permit No. EP-356/2009

		Name	Signature
Certified by:	Environmental Team Leader	RAYMOND DAI	
Verified by:	Independent Environmental Checker	David Yeung	

CONTENTS

		Page
1	INTRODUCTION	1-1
1.1	Purpose of the Manual.....	1-1
1.2	Project Description	1-1
1.3	Environmental Monitoring and Audit Requirements.....	1-3
1.4	Project Organisation.....	1-6
1.5	Latest Project Information.....	1-9
2	AIR QUALITY.....	2-1
2.1	Introduction	2-1
2.2	Air Quality Parameters.....	2-1
2.3	Monitoring Equipment.....	2-2
2.4	Laboratory Measurement / Analysis.....	2-3
2.5	Monitoring Locations.....	2-3
2.6	Baseline Monitoring	2-4
2.7	Impact Monitoring of Construction Air Quality Impact	2-5
2.8	Impact Monitoring of Odour Patrol	2-6
2.9	Impact Monitoring of Operation Air Quality Impact.....	2-6
2.10	Environmental Quality Performance Limits.....	2-7
2.11	Event and Action Plan	2-7
2.12	Mitigation Measures	2-11
3	NOISE	3-1
3.1	Introduction	3-1
3.2	Noise Parameters.....	3-1
3.3	Monitoring Equipment.....	3-1
3.4	Monitoring Locations.....	3-2
3.5	Baseline Monitoring	3-3
3.6	Impact Monitoring	3-3
3.7	Event and Action Plan	3-5
3.8	Noise Mitigation Measures.....	3-5
4	WATER QUALITY	4-1
4.1	Water Quality Parameters.....	4-1
4.2	Monitoring Equipment.....	4-1
4.3	Laboratory Measurement / Analysis.....	4-2
4.4	Monitoring Locations.....	4-3
4.5	Baseline Monitoring	4-4
4.6	Impact Monitoring.....	4-5
4.7	Post-construction Monitoring.....	4-7
4.8	Field Log	4-7
4.9	Construction Site Audits	4-7
4.10	Event and Action Plan for Construction Water Quality	4-8
4.11	Mitigation of Adverse Environmental Impacts.....	4-10
5	WASTE MANAGEMENT	5-1
5.1	Introduction	5-1
5.2	Waste Control and Mitigation Measures.....	5-1
6	(NOT USED)	
7	MARINE ECOLOGY	7-1
7.1	Introduction	7-1
7.2	Mitigation measures for corals	7-1
7.3	Monitoring requirement.....	7-2

8	LANDSCAPE AND VISUAL	8-1
8.1	Introduction	8-1
8.2	Monitoring Details.....	8-1
8.3	Baseline Monitoring	8-2
8.4	Event/Action Plan for Landscape and Visual Works	8-2
8.5	Mitigation Measures	8-4
9	SITE ENVIRONMENTAL AUDIT.....	9-1
9.1	Site Inspection.....	9-1
9.2	Compliance with Legal and Contractual Requirements.....	9-2
9.3	Environmental Complaints.....	9-2
10	REPORTING	10-1
10.1	General	10-1
10.2	Baseline Monitoring Report.....	10-1
10.3	Monthly EM&A Reports	10-2
10.4	Quarterly EM&A Summary Reports.....	10-7
10.5	Final EM&A Review Reports.....	10-8
10.6	Reporting for Post-construction / Post-Translocation Monitoring of Coral.....	10-10
10.7	Operation Phase EM&A Report	10-10
10.8	Data Keeping.....	10-10
10.9	Interim Notifications of Environmental Quality Limit Exceedances	10-10

LIST OF FIGURES

Figure 1.2c	Designated Project 3: Reclamation works including associated Dredging Works
Figure 1.2e	Designated Project 5: Wan Chai East Sewage Outfall
Figure 1.2f	Designated Project 6: Dredging for the Cross-Harbour Water Mains from Wan Chai to Tsim Sha Tsui
Figure 1.3	Project Organisation
Figure 2.1	Locations of Representative Air Sensitive Receivers
Figure 2.2	Proposed Monitoring Locations During Construction Phase
Figure 2.3	Proposed Odour Monitoring Route During Operation Phase
Figure 3.1	Locations of Representative Noise Sensitive Receivers
Figure 3.2	Locations of Construction Noise Monitoring Stations
Figure 4.1a	Locations of Water Quality Monitoring Stations (Sheet 1 of 2)
Figure 4.1b	Locations of Water Quality Monitoring Stations (Sheet 2 of 2)
Figure 4.1c	Layout plan for Scope of Works for each of the Contracts and Water Quality Monitoring Stations
Figure 7.1	Spot-check Dive Sites and REA Transects (Sheet 1 of 2)
Figure 7.2	Spot-check Dive Sites and REA Transects (Sheet 2 of 2)
Figure 7.3	Proposed Coral Recipient Site at Junk Bay
Figure 8.1a	Baseline Landscape Resources During Construction
Figure 8.1b	Baseline Landscape Resources During Operation
Figure 8.2a	Baseline Landscape Character Areas During Construction
Figure 8.2b	Baseline Landscape Character Areas During Operation
Figure 8.3a	Key VSRs and Primary Zone of Visual Influence During Construction
Figure 8.3b	Key VSRs and Primary Zone of Visual Influence During Operation
Figure 8.3c	Key VSRs and Secondary Zone of Visual Influence

LIST OF APPENDICES

Appendix A	Implementation Schedule
Appendix B	Sample Data Sheets for Air Quality, Noise and Water Quality Monitoring
Appendix C	Sample Template for the Interim Notifications
Appendix D	Establishment of Seasonal Action and Limit Levels
Appendix K	Terms of Reference and Details for the ENPC and CLG
Appendix L	Sketch A for Enhanced Water Quality Monitoring and Audit Programme
Appendix M	Details of Real-time Noise Monitoring System
Appendix N	Construction Programmes of Works Contracts

CONTENTS

1	INTRODUCTION.....	1-1
1.1	Purpose of the Manual.....	1-1
1.2	Project Description.....	1-1
1.3	Environmental Monitoring and Audit Requirements.....	1-3
1.4	Project Organisation.....	1-6
1.5	Latest Project Information.....	1-9

LIST OF FIGURES

Figure 1.2c	Designated Project 3 – Reclamation Works Including Associated Dredging Works
Figure 1.2e	Designated Project 5 – Wan Chai East Sewage Outfall
Figure 1.2f	Designated Project 6 – Dredging for the Cross – Harbour Water Mains from Wan Chai to Tsim Sha Tsui
Figure 1.3	Project Organization

LIST OF APPENDICES

Appendix K	Terms of Reference and Details for the ENPC and CLG
Appendix N	Construction Programmes of Works Contracts

1 INTRODUCTION

1.1 Purpose of the Manual

1.1.1 The purpose of this Environmental Monitoring and Audit (EM&A) Manual is to guide the set up of an EM&A programme for the Designated Projects (DPs) covered by the Environmental Permit (EP) No. EP-356/2009 to ensure compliance with the Environmental Impact Assessment (EIA) study recommendations, to assess the effectiveness of the recommended mitigation measures and to identify any further need for additional mitigation measures or remedial action. This Manual outlines the monitoring and audit programme for the construction and operation of parts of the works under the proposed Wan Chai Development Phase II (WDII) and for the construction of the Central-Wan Chai Bypass (CWB). It aims to provide systematic procedures for monitoring, auditing and minimising environmental impacts associated with construction works and operational activities.

1.1.2 Hong Kong environmental regulations and the Hong Kong Planning Standards and Guidelines have served as environmental standards and guidelines in the preparation of this Manual. In addition, the EM&A Manual has been prepared in accordance with the requirements stipulated in Annex 21 of the Technical Memorandum on the EIA Process (EIAO-TM).

1.1.3 This Manual contains the following information:

- responsibilities of the Contractor, the Engineer or Engineer's Representative (ER), Environmental Team (ET), and the Independent Environmental Checker (IEC) with respect to the environmental monitoring and audit requirements during the course of the project;
- project organisation for the project;
- the basis for, and description of the broad approach underlying the EM&A programme;
- requirements with respect to the construction programme (as stated in Volume 5, Appendix 2.5 of the EIA Report) schedule and the necessary environmental monitoring and audit programme to track the varying environmental impact;
- details of the methodologies to be adopted, including all field laboratories and analytical procedures, and details on quality assurance and quality control programme;
- the rationale on which the environmental monitoring data will be evaluated and interpreted;
- definition of Action and Limit levels;
- establishment of Event and Action plans;
- requirements for reviewing pollution sources and working procedures required in the event of non-compliance with the environmental criteria and complaints;
- requirements for presentation of environmental monitoring and audit data and appropriate reporting procedures; and
- requirements for review of EIA predictions and the effectiveness of the mitigation measures / environmental management systems and the EM&A programme.

1.1.4 For the purpose of this manual, the ET leader, who shall be responsible for and in charge of the ET, shall refer to the person delegated the role of executing the EM&A requirements.

1.2 Project Description

Site Location

1.2.1 The DPs covered by the EP No. EP-356/2009 are located mainly in Wan Chai North, Causeway Bay and North Point, and is demarcated by Gloucester Road and Victoria Park Road to the south, Fenwick Pier Street to the west and Tong Shui Road Interchange to the east.

1.2.2 Three DPs are covered by the EP No. EP-356/2009, and for the purposes of this updated EM&A manual, the "Project" will include all these three DPs under the EP No. EP-356/2009. The description of these three DPs are given below:

- DP3 - Reclamation works including associated dredging works

The project is driven by the need for the implementation of the Trunk Road (CWB), which will form an east-west strategic route through Central and Wan Chai to the existing Island Eastern Corridor (IEC). Construction of this Trunk Road will, though, require permanent reclamation in the areas to the west of Hong Kong Convention and Exhibition Centre (HKCEC), through the HKCEC water channel, along the Wan Chai shoreline and along the North Point shoreline. Permanent reclamation is not required in the ex-Public Cargo Working Area (PCWA) basin or in the CBTS.

During the Trunk Road construction, temporary reclamation will be required in the ex-PCWA basin and the CBTS to facilitate cut-and-cover tunnel construction of the Trunk Road. After construction of the Trunk Road, the temporary reclamation will be removed and the ex-PCWA basin and the CBTS will be reinstated.

The total volume of sediments to be dredged and disposed is estimated to be approximately 1.15 Mm³.

The minimum area of permanent reclamation required is summarised as follows:

(i)	HKCEC West:	3.7 ha
(ii)	HKCEC Water Channel:	1.6 ha
(iii)	Wan Chai Shoreline:	4.1 ha
(iv)	North Point Shoreline:	3.3 ha

The total reclamation area is 12.7 ha. Since the reclamation is more than 5 ha in size, it is classified as a DP under Schedule 2, Part I, C1.

For the mitigation of odour, dredging to remove the polluted sediments at the south-west corner of the CBTS will be carried out during the implementation of harbour-front enhancement and forms part of DP3.

Further, as dredging will be carried out less than 100m from a seawater intake, it would also be classified as a DP under Schedule 2, Part I, C.12.

The location of DP3 is shown in **Figure 1.2c**.

- DP5 – Wan Chai East Sewage Outfall

The Wan Chai West Sewage Screening Plant will be decommissioned once flows have been diverted to the Wan Chai East Sewage Screening Plant. The Wan Chai East Sewage Screening Plant will have adequate capacity to handle these flows. However, in the longer term, the existing sewage outfall will need to be upgraded to handle the future design flows. A new sewage outfall will be constructed to replace and upgrade the existing Wan Chai East sewage outfall. The configuration of the new sewage outfall will comprise a landfall section of 2,250mm diameter pipe with approximate length of 180m, and a marine section of twin 1,600mm diameter submarine pipelines of about 550m length. As the twin submarine sewage pipelines comprise a total diameter more than 1,200mm and include submarine sewage outfall, it is classified as DP under Schedule 2 Part I, F.5 and F.6. The location of this DP5 is shown in **Figure 1.2e**.

- DP6 – Dredging for the Cross-harbour Water Mains from Wan Chai to Tsim Sha Tsui

An existing cross harbour fresh water mains of about 1.1 km length and comprising twin 1,000 mm diameter steel submarine pipelines runs from Tsim Sha Tsui, along the west

of the MTR Tsuen Wan Line to a landfall at the seafrontage north of the Wan Chai West Sewage Screening Plant, near Lung King Street. The reclamation works could potentially damage the watermains and diversion of these mains will be necessary. The total dredged volume for the construction of the cross-harbour watermain is estimated to be approximately 0.06Mm³. As dredging for the installation of the new cross harbour watermains will be carried out less than 100m from a seawater intake, it is classified as DP under Schedule 2, Part I, C.12. The location of this DP6 is shown in **Figure 1.2f**.

Construction Programme

- 1.2.3 The construction works of the DPs have commenced in early 2010 and will be completed by 2017. The construction programmes in **Appendix N** refer.

1.3 Environmental Monitoring and Audit Requirements

- 1.3.1 The following sub-sections summarise the EM&A requirements recommended in the approved Wan Chai Development Phase II and Central – Wan Chai Bypass Environmental Impact Assessment Report (December 2007) (Register No. AEIAR-125/2008).

Air Quality Impact

Construction Phase

- 1.3.2 The construction work will inevitably lead to dust (Total Suspended Particulates, TSP) emissions, mainly from excavation, truck haulage and material handling. It is predicted that the dust generated will exceed the hourly and daily criteria of 500 µg m⁻³ and 260 µg m⁻³, respectively, at ASRs from Wan Chai to Causeway Bay.
- 1.3.3 Mitigation measures, including vehicle speed limit and a watering programme within the site, have been proposed and presented in the EIA Report. With implementation of the proposed dust suppression measures, good site practices and comprehensive dust monitoring and audit, the TSP levels at all ASRs will comply with the dust criteria. Dust monitoring requirements are recommended in Section 2 of this EM&A Manual to ensure the efficacy of the control measures.

Operational Phase

- 1.3.4 As presented in Volume 1, Section 3.7 of the EIA Report, the predicted air quality due to traffic emission in the study area complies with the AQO. The DP3, DP5 and DP6 will not generate traffic in the operational phase and hence will not create air quality impact due to traffic emission. No mitigation measures or environmental monitoring are considered necessary during the operational phase of the Project. Regarding the odour issue, this Project will not create any new odour source during operational phase. However, odour nuisance associated with the Causeway Bay Typhoon Shelter is an existing environmental problem. In order to improve the environment, this Project will take the opportunities to mitigate the potential sources of odour nuisance within the Project area so as to alleviate this existing environmental problem as well as to provide an acceptable environment for the future land uses within the project area. Enhancement measures have been formulated to alleviate this existing odour problem. To ascertain the effectiveness of the Enhancement Package over time, and to monitor any on-going odour impacts at the ASRs, annual monitoring of odour impacts is proposed during the operational phase of the Project.

Noise Impact

Construction Phase

- 1.3.5 Construction noise impacts from this Project, in addition to the concurrent construction tasks of other projects such as CR11, are predicted at the NSRs identified in this EIA. Appropriate mitigation measures, including movable noise barriers and reducing the percentage of on-time operation of the powered mechanical equipment, are required in order to alleviate the impacts to meet the EIAO-TM criteria. Noise monitoring during construction phase will have to be carried out to ensure that such mitigation measures have been implemented properly. Details are provided in Section 3 of this EM&A Manual.
- 1.3.6 A real-time on-site monitoring system of the noise level around the works sites at North Point and Tin Hau areas shall be carried out during the construction phase. The methodology is also presented in Section 3 of this EM&A Manual.

Operational Phase

- 1.3.7 The DP3, DP5 and DP6 will not generate vehicular traffic in the operational phase and hence traffic noise monitoring is not required in this EM&A Manual..

Water Quality Impact

Construction Phase

- 1.3.8 A water quality monitoring and audit programme will be conducted during dredging and filling operations to verify whether or not impact predictions are representative, and to ensure that the dredging and filling operations do not result in unacceptable impacts. When monitoring shows unacceptable water quality impact, appropriate mitigation measures, such as changes in the operation of marine works, will be introduced.
- 1.3.9 Water quality monitoring should be carried out at selected potentially affected sensitive receivers, to assess whether or not impacts follow the predictions made in this EIA. Section 4 of this EM&A Manual includes site-specific monitoring and auditing protocols for baseline and all stages of the dredging operations. Such protocols include but are not limited to the locations of monitoring stations, parameters and frequencies for monitoring, monitoring equipment, data management procedures, and reporting of monitoring results.
- 1.3.10 In order to avoid aggravation of odour nuisance from seawater arising from temporary reclamation in the ex-Wan Chai Public Cargo Working Area and the Causeway Bay Typhoon Shelter, odour patrol shall be conducted by independent trained personnel / competent persons patrolling and sniffing along the ex-Wan Chai Public Cargo Working Area and the Causeway Bay Typhoon Shelter during the reclamation work. The odour patrol methodology is presented in Section 4 of this EM&A Manual.
- 1.3.11 Environmental audit specifications should be developed for all phases of the works, including procedures to ensure compliance with mitigation measures, environmental quality performance limits, and procedures for reviewing results and auditing compliance with specified performance limits.

Operational Phase

- 1.3.12 As adverse water quality impact will not be generated from the operation of the Project, operational water quality monitoring and audit is not considered necessary.

Waste Management

- 1.3.13 Waste management will be the contractor's responsibility to ensure that all wastes produced during the construction of the Project are handled, stored and disposed of in accordance with EPD's good waste management practices, and regulations and requirements. The mitigation measures recommended include special procedures in handling contaminated sediment during disposal and transportation, good site management and reuse and recycling of construction and demolition material, should form the basis of the site Waste Management Plan to be developed

by the Contractor at the construction stage. These measures include special handling procedures in dredged marine sediment transportation and disposal, good site practices and waste reduction measures, reuse and recycling of construction and demolition materials.

- 1.3.14 It is recommended that the waste arisings generated during the construction activities should be audited periodically to determine if wastes are being managed in accordance with approved procedures and the site Waste Management Plan. The audits should look at all aspects of waste management including waste generation, storage, recycling, transport and disposal. An appropriate audit programme would be to undertake a first audit near the commencement of the construction works, and then to audit quarterly thereafter. Details are presented in Section 5 of this EM&A Manual.

Land Contamination

Construction Phase

- 1.3.15 As there will be no adverse land contamination impact arising from the construction of the DP3, DP5 and DP6, construction phase land contamination monitoring and audit is considered not necessary and will not be covered in this updated EM&A Manual.

Operational Phase

- 1.3.16 As adverse land contamination impact is not anticipated from the operation of the Project, operational land contamination monitoring and audit is considered not necessary and will not be covered in this EM&A Manual.

Marine Ecology

- 1.3.17 Translocation of all 21 coral colonies found within the proposed reclamation area to other suitable locations such as Junk Bay is recommended. Detailed translocation plan (including the translocation methodology and monitoring of transplanted corals) should be drafted during the detailed design phase of the Project. The translocation works should be completed before the commencement of construction phase of the Project.
- 1.3.18 It is recommended to implement monitoring of the transplanted corals after translocation. The health status of each transplanted coral colony should be carefully recorded. For hard corals, this should include information on surface area with partial mortality and blanched / bleached area. For gorgonian coral, the percentage of branches affected by partial mortality should be recorded. The translocation methodology, monitoring proposal and the ecologist involved in this coral translocation exercise should be approved by the AFCD prior to the commencement of this exercise.

Landscape and Visual Impact

Construction Phase

- 1.3.19 Construction activities would give rise to landscape and visual impacts varying from slight to substantial significance.
- 1.3.20 The landscape and visual mitigation measures for the construction phase are described in Volume 1, Section 10 of the EIA Report. The measures are on-site management measures to be undertaken by the contractor. Monitoring of the Contractor to ensure that the measures are carried out properly should be undertaken by the resident site staff.

Operational Phase

- 1.3.21 The operation of the Project would give rise to landscape and visual impacts of varying from moderate negative to moderate beneficial. Overall, it is considered that the residual landscape and visual impacts of the proposed development and the associated designated projects are considered **acceptable with mitigation measures** during operation up to 10 years and **beneficial with mitigation** in the long run after 20 to 30 years.
- 1.3.22 The proposed landscape and visual mitigation measures are described in Volume 1, Section 10 of the EIA Report. The measures are design measures to be incorporated in the detailed planning and design of the reclamation, infrastructure and open space works.

1.4 Project Organisation

- 1.4.1 The construction of the Project will involve several construction contracts and hence multiple contractors may be employed at the work site. In view of this, an ET should be employed (or an Environmental Project Offices (ENPO) be established) by the Project Proponent to maintain impartially. The proposed project organisation and lines of communication with respect to environmental protection works are shown in Figure 1.3.

Figure 1.3 Project Organisation

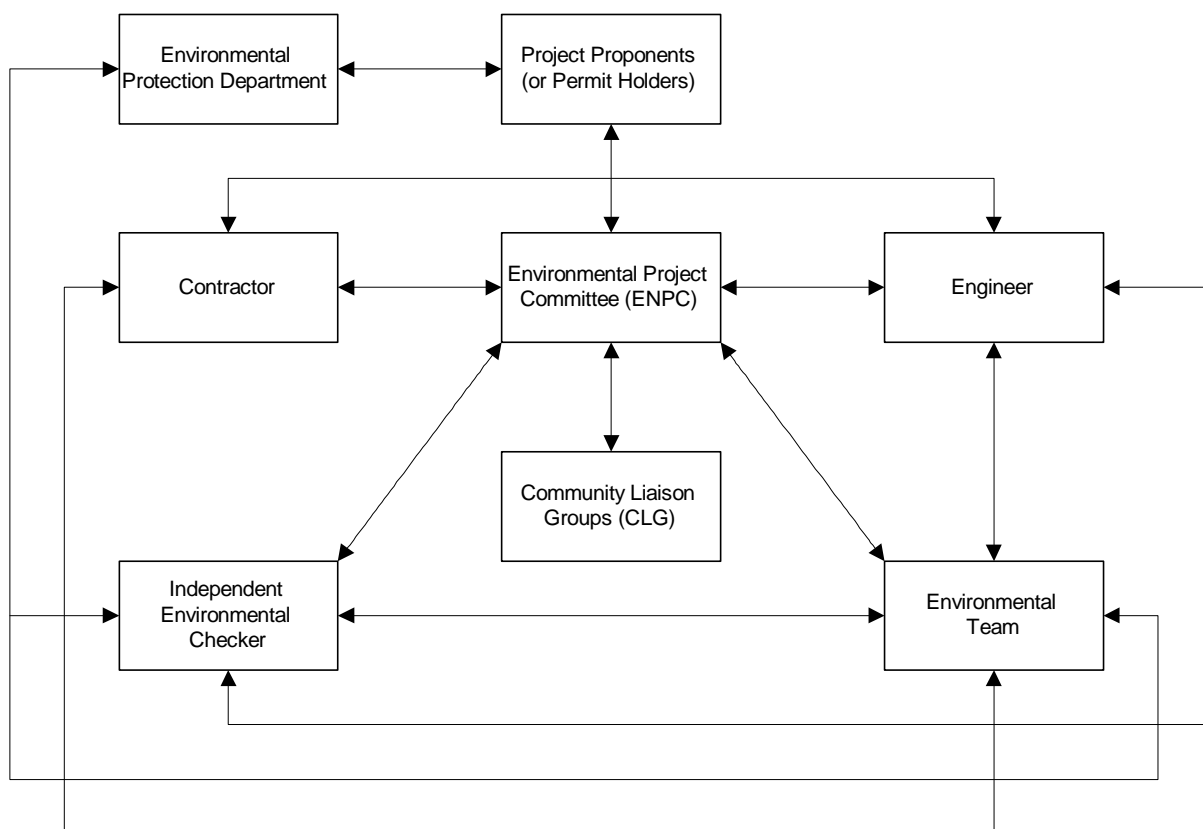

The Contractor

- 1.4.2 The Contractor shall report to the Engineer. The duties and responsibilities of the Contractor are:
- provide assistance to ET in carrying out monitoring;
 - submit proposals on mitigation measures in case of exceedances of Action and Limit levels in accordance with the Event and Action Plans;
 - implement measures to reduce impact where Action and Limit levels are exceeded; and
 - adhere to the procedures for carrying out complaint investigation in accordance with Section 9.3 of this EM&A Manual.

Environmental Team

- 1.4.3 The ET Leader and the ET shall be employed to conduct the EM&A programme and ensure the Contractor's compliance with the project's environmental performance requirements during construction. The ET Leader shall be an independent party from the Contractor and have relevant professional qualifications, or have sufficient relevant EM&A experience subject to approval of the Environmental Protection Department (EPD). The ET shall be led and managed by the ET leader. The ET leader shall possess at least 7 years experience in EM&A. The ET team shall include a landscape auditor to audit the mitigation measures implemented by the Contractor on a regular basis to ensure compliance with the intended aims of the measures. The duties and responsibilities of the ET are:

- monitor various environmental parameters as required in the EM&A Manual;
- analyse the environmental monitoring and audit data and review the success of EM&A programme to cost-effectively confirm the adequacy of mitigation measures implemented and the validity of the EIA predictions and to identify any adverse environmental impacts arising;
- carry out site inspection to investigate and audit the Contractors' site practice, equipment and work methodologies with respect to pollution control and environmental mitigation, and effect proactive action to pre-empt problems;
- audit and prepare audit reports on the environmental monitoring data and site environmental conditions;
- report on the environmental monitoring and audit results to the IEC, Contractor, the ER and EPD or its delegated representative;
- recommend suitable mitigation measures to the Contractor in the case of exceedance of Action and Limit levels in accordance with the Event and Action Plans; and
- adhere to the procedures for carrying out complaint investigation in accordance with Section 9.3 of this EM&A Manual.

Engineer or Engineer's Representative

- 1.4.4 The Engineer is responsible for overseeing the construction works and for ensuring that the works undertaken by the Contractor in accordance with the specification and contractual requirements. The duties and responsibilities of the Engineer with respect to EM&A may include:
- supervise the Contractor's activities and ensure that the requirements in the EM&A Manual are fully complied with;
 - inform the Contractor when action is required to reduce impacts in accordance with the Event and Action Plans; and
 - adhere to the procedures for carrying out complaint investigation in accordance with Section 9.3 of this EM&A Manual.

Independent Environmental Checker (IEC)

- 1.4.5 The IEC shall advise the Engineer's Representative on environmental issues related to the project. The IEC shall possess at least 7 years experience in EM&A. The duties and responsibilities of the IEC are:
- review the EM&A works performed by the ET (at not less than monthly intervals);
 - audit the monitoring activities and results (at not less than monthly intervals);
 - report the audit results to the ER and EPD in parallel;
 - review the EM&A reports (monthly and quarterly summary reports) submitted by the ET;
 - review the proposal on mitigation measures submitted by the Contractor in accordance with the Event and Action Plans; and
 - adhere to the procedures for carrying out complaint investigation in accordance with Section 9.3 of this EM&A Manual.
- 1.4.6 Sufficient and suitably qualified professional and technical staff shall be employed by the respective parties to ensure full compliance with their duties and responsibilities, as required under the EM&A programme for the duration of the Project.

Environmental Project Committee (ENPC)

- 1.4.7 To oversee and facilitate effective control of the cumulative environmental impacts arising from potential multiple contracts for the construction of the entire Wan Chai Development Phase II (WDII) and Central-Wan Chai Bypass (CWB) (hereafter referred to as the whole Project), the Permit Holder shall set up an Environmental Project Committee (ENPC) before the commencement of construction of the earliest components of the whole Project. Regular members of the ENPC will include:
- (a) the ET Leader;
 - (b) the IEC; and
 - (c) the permit holders of any environmental permit(s) and further environmental permit(s) for the whole Project.

The Community Liaison Group formed shall also work under the ENPC set-up to facilitate any necessary liaison works to address potential cumulative environmental impact issues arising from the whole Project. The ENPC shall make recommendation and update on how to enhance the monitoring and audit of the environmental performance of the whole Project on top of requirements as set out in Conditions 3.1 to 4.3 of the Environmental Permit No. EP-356/2009 or corresponding requirements set out under subsequent Environmental Permits issued for the whole Project.

In order to enhance the monitoring and audit environmental performance of the project, ENPC will be required to set up regular meeting on monthly basis in association with environmental site inspection for the entire Wan Chai Development Phase II (WDII) and Central-Wan Chai Bypass (CWB) to undertake the latest cumulative environmental impacts. The frequency of the meeting will be reviewed subject to the environmental performance of the whole Project and ad-hoc meeting will be required if necessary.

The proposed terms of reference and details for the ENPC is presented in **Appendix K**.

Community Liaison Group (CLG)

Community Liaison Group will comprise representatives from the relevant concerned and affected parties, including owners' corporation, management offices, local committee and schools of affected areas, including the North Point and Tin Hau areas, to facilitate

communication, enquires and complaint handling on all environmental issues, including the follow up on the implementation of remedial mitigation measures. Regular meeting on monthly basis will be setup for the Community Liaison Group to update the latest cumulative environmental impacts due to the project. The frequency of the meeting will be reviewed subject to the environmental performance of the whole Project and ad-hoc meeting will be required if necessary.

- 1.4.8 The Permit Holder shall set up the CLG before the commencement of construction of the relevant component(s) of the WDII and CWB Project. The Permit Holder shall notify the Director the actual date of setting up the CLG, the membership, the terms of reference and the contact details. A designated complaint hotline shall also be set up for the Project to address such concerns and complaints in an efficient manner. The detailed arrangements of the CLG shall be reported to the ENPC and its activities be reflected as update under Condition 2.5(a) of the Environmental Permit No. EP-356/2009.

The proposed terms of reference and details for the CLG is presented in **Appendix K**.

1.5 Latest Project Information

- 1.5.1 The latest works programmes of the works contracts covered by EP-356/2009 are provided in **Appendix N**.

CONTENTS

2	AIR QUALITY.....	2-1
2.1	Introduction.....	2-1
2.2	Air Quality Parameters.....	2-1
2.3	Monitoring Equipment.....	2-2
2.4	Laboratory Measurement / Analysis.....	2-3
2.5	Monitoring Locations.....	2-3
2.6	Baseline Monitoring.....	2-4
2.7	Impact Monitoring of Construction Air Quality Impact.....	2-5
2.8	Impact Monitoring for Odour Patrol.....	2-6
2.9	Impact Monitoring of Operation Air Quality Impact.....	2-6
2.10	Environmental Quality Performance Limits.....	2-7
2.11	Event and Action Plan.....	2-7
2.12	Mitigation Measures.....	2-11

LIST OF TABLES

Table 2.1	Locations of Dust Monitoring Locations
Table 2.2	Division of Dust Monitoring Stations for contracts with construction work commenced/to be commenced in 2010
Table 2.3	Action / Limit Levels for Odour Patrol
Table 2.4	Action / Limit Levels for Air Quality
Table 2.5	Event / Action Plan for Construction Air Quality
Table 2.6	Event/Action Plan for Odour Patrol
Table 2.7	Event/Action Plan for Operation Air Quality Monitoring

LIST OF FIGURES

Figure 2.1	Locations of Representative Air Sensitive Receivers
Figure 2.2	Proposed Dust Monitoring Locations During Construction Phase
Figure 2.3	Proposed Odour Monitoring Location During Operation Phase

LIST OF APPENDICES

Appendix A	Implementation Schedule of Recommended Mitigation Measures
Appendix B	Data Record Sheet

2 AIR QUALITY

2.1 Introduction

- 2.1.1 In this section, the general requirements, methodology, equipment, monitoring locations, criteria and protocols for the monitoring and audit of air quality impacts during the construction phase of all WDII and CWB works, including entrustment works from HyD, are presented. As the construction dust is the prime concern, TSP levels shall be monitored to evaluate the dust impact during the construction phase.
- 2.1.2 The findings of the EIA also indicated that the existing odour sources at CBTS would have potential odour impact on the planned Air Sensitive Receivers (ASR) under WDII Project during operation phase of the Project. Odour monitoring would be required to determine the effectiveness of mitigation measures and monitor the residual odour impact on the planned ASR.
- 2.1.3 There will be no exceedance of AQOs at the sensitive receivers and hence air quality monitoring is considered not necessary during the operation phase of the Project.
- 2.1.4 During operational phase, this Project will not create any new odour source. However, odour nuisance associated with the Causeway Bay Typhoon Shelter (CBTS) is an existing environmental problem. In order to improve the environment, this Project will take the opportunities to mitigate the potential sources of odour nuisance within the Project area so as to alleviate this existing environmental problem as well as to provide an acceptable environment for the future land uses within the project area (including the proposed open space at the northern breakwater). Enhancement measures have been formulated to alleviate this existing odour problem. With the implementation of the enhancement measures, the predicted odour levels in the vicinity of CBTS would be reduced significantly. In other words, this Project will alleviate the existing odour problems in the vicinity of CBTS to a large extent by implementing the proposed enhancement measures. To ascertain the effectiveness of the Enhancement Package over time, and to monitor any on-going odour impacts at the ASRs, regular monitoring of odour impacts in the first five years upon commissioning of the Project is proposed during the operational phase.

2.2 Air Quality Parameters

Construction Phase

- 2.2.1 Monitoring and audit of the TSP levels shall be carried out by the ET to ensure that any deteriorating air quality could be readily detected and timely action taken to rectify the situation.
- 2.2.2 One-hour and 24-hour TSP levels should be measured to indicate the impacts of construction dust on air quality. The 24-hour TSP levels shall be measured by following the standard high volume sampling method as set out in the Title 40 of the Code of Federal Regulations, Chapter 1 (Part 50), Appendix B.
- 2.2.3 All relevant data including temperature, pressure, weather conditions, elapsed-time meter reading for the start and stop of the sampler, identification and weight of the filter paper, and any other local atmospheric factors affecting or affected by site conditions, etc., shall be recorded down in detail. A sample data sheet is shown in **Appendix B1**.
- 2.2.4 The locations of air sensitive receivers (ASRs) within and adjacent to the Project work site are shown in **Figure 2.1**.

Operation Phase

- 2.2.5 Odour patrol should be conducted by independent trained personnel / competent persons patrolling and sniffing at the planned ASR to indicate the operational odour impacts.

2.3 Monitoring Equipment

Construction Phase

- 2.3.1 High volume samplers (HVSs) in compliance with the following specifications shall be used for carrying out the 1-hour and 24-hour TSP monitoring:
- a) 0.6 - 1.7 m³ per minute adjustable flow range;
 - b) equipped with a timing / control device with +/- 5 minutes accuracy for 24 hours operation;
 - c) installed with elapsed-time meter with +/- 2 minutes accuracy for 24 hours operation;
 - d) capable of providing a minimum exposed area of 406 cm²;
 - e) flow control accuracy: +/- 2.5% deviation over 24-hour sampling period;
 - f) equipped with a shelter to protect the filter and sampler;
 - g) incorporated with an electronic mass flow rate controller or other equivalent devices;
 - h) equipped with a flow recorder for continuous monitoring;
 - i) provided with a peaked roof inlet;
 - j) incorporated with a manometer;
 - k) able to hold and seal the filter paper to the sampler housing at horizontal position;
 - l) easily changeable filter; and
 - m) capable of operating continuously for a 24-hour period.
- 2.3.2 The ET is responsible for provision of the monitoring equipment. They shall ensure that sufficient number of HVSs with an appropriate calibration kit are available for carrying out the baseline monitoring, regular impact monitoring and *ad hoc* monitoring. The HVSs shall be equipped with an electronic mass flow controller and be calibrated against a traceable standard at regular intervals. All the equipment, calibration kit, filter papers, etc., shall be clearly labelled.
- 2.3.3 Initial calibration of dust monitoring equipment shall be conducted upon installation and thereafter at bi-monthly intervals. The transfer standard shall be traceable to the internationally recognised primary standard and be calibrated annually. The concern parties such as IEC shall properly document the calibration data for future reference. All the data should be converted into standard temperature and pressure condition.
- 2.3.4 The flow-rate of the sampler before and after the sampling exercise with the filter in position shall be verified to be constant and be recorded in the data sheet as mentioned in **Appendix B1**.
- 2.3.5 If the ET proposes to use a direct reading dust meter to measure 1-hour TSP levels, he shall submit sufficient information to the IEC to prove that the instrument is capable of achieving a comparable result to the HVS. The instrument should also be calibrated regularly, and the 1-hour sampling shall be determined periodically by the HVS to check the validity and accuracy of the results measured by direct reading method.
- 2.3.6 Wind data monitoring equipment shall also be provided and set up set up for logging wind speed and wind direction near the dust monitoring locations. The equipment installation location shall be proposed by the ET and agreed with the IEC. For installation and operation of wind data monitoring equipment, the following points shall be observed:
- a) The wind sensors should be installed 10 m above ground so that they are clear of obstructions or turbulence caused by buildings.
 - b) The wind data should be captured by a data logger. The data shall be downloaded for analysis at least once a month.
 - c) The wind data monitoring equipment should be re-calibrated at least once every six months.
 - d) Wind direction should be divided into 16 sectors of 22.5 degrees each.
- 2.3.7 In exceptional situations, the ET may propose alternative methods to obtain representative wind data upon approval from the ER and agreement from the IEC.

2.4 Laboratory Measurement / Analysis

Construction Phase

- 2.4.1 A clean laboratory with constant temperature and humidity control, and equipped with necessary measuring and conditioning instruments to handle the dust samples collected, shall be available for sample analysis, and equipment calibration and maintenance. The laboratory should be HOKLAS accredited.
- 2.4.2 If a site laboratory is set up or a non-HOKLAS accredited laboratory is hired for carrying out the laboratory analysis, the laboratory equipment shall be approved by the ER and the measurement procedures shall be witnessed by the IEC. Any measurement performed by the laboratory shall be demonstrated to the satisfaction of the ER and IEC. IEC shall regularly audit to the measurement performed by the laboratory to ensure the accuracy of measurement results. The ET Leader shall provide the ER with one copy of the Title 40 of the Code of Federal Regulations, Chapter 1 (Part 50), Appendix B for his reference.
- 2.4.3 Filter paper of size 8" x 10" shall be labelled before sampling. It shall be a clean filter paper with no pinholes, and shall be conditioned in a humidity-controlled chamber for over 24-hours and be pre-weighed before use for the sampling.
- 2.4.4 After sampling, the filter paper loaded with dust shall be kept in a clean and tightly sealed plastic bag. The filter paper shall then be returned to the laboratory for reconditioning in the humidity-controlled chamber followed by accurate weighing by an electronic balance with readout down to 0.1 mg. The balance shall be regularly calibrated against a traceable standard.
- 2.4.5 All the collected samples shall be kept in a good condition for 6 months before disposal.

2.5 Monitoring Locations

- 2.5.1 Based on the findings of the EIA report, 5 representative locations which would be the worst affected locations in different area are designated for construction dust monitoring. As per the consent obtained from appropriate sensitive receiver for provision of location for monitoring, the latest status of dust monitoring stations for construction phase are presented in **Table 2.1** and shown in **Figure 2.2** proposed after seeking approval from ER and agreement from the IEC. The status and locations of dust sensitive receivers may change after issuing this manual. If such cases exist, the ET Leader shall propose updated monitoring locations and seek approval from ER and IEC and agreement from EPD on the proposal. The odour monitoring route for construction and operation phases are shown in the **Sketch A** in **Appendix L** and in **Figure 2.3**.

Table 2.1 Locations of Dust Monitoring Locations

Identification No.	Location	Level (in terms of no. of floor)
CMA1b	North Point – Oil Street Community Liaison Centre	G/F
CMA2a	Causeway Bay – Causeway Bay Community Centre	4
CMA3a	Causeway Bay – CWB site office at Wanchai Waterfront Promenade	G/F
CMA4a	Wanchai – Society for the Prevention of Cruelty to Animals (SPCA)	6 (roof-top)
CMA5a	Wanchai – Children Playgrounds opposite to Pedestrian Plaza	G/F
CMA6a	Wanchai – WDII site office at Wanchai North	1/F

The status and locations of the air sensitive receivers may change after issuing this Manual. If such cases exist, the ET Leader shall propose updated monitoring locations and seek approval from the ER and agreement from the IEC.

Commencement of Dust Monitoring Programme in Stages

- 2.5.2 As per the condition 2.5(d) under EP-356/2009, environmental monitoring and the execution of Event & Action Plan (EAP) are considered based on taken into account of the latest works schedules, division of responsibilities among different contracts in the Project, and latest project information. Division of work areas under different contracts will be managed under separate FEPs applied by individual contractors.
- 2.5.3 In terms of division of work areas, the proposed division of dust monitoring stations and its commencement in stages are summarized in Table 2.2.

Table 2.2 Division of Dust Monitoring Stations for contracts with construction work commenced/to be commenced in 2010

Contract No.	Associated DP(s)	Relevant Dust Monitoring Stations¹	Commencement of monitoring w.r.t construction commencement
HY/2009/11	DP3	CMA1b, CMA2a	Site formation work within the reclaimed area ¹
HK/2009/01	DP3, DP6	CMA5a, CMA6a	Site formation work within the reclaimed area ¹
HK/2009/02	DP3, DP5	CMA4a	Site formation work within the reclaimed area ¹
HY/2009/15	DP3	CMA3a	Site formation work within the reclaimed area ¹

Note 1: Subject to actual commencement date to be confirmed.

2.6 Baseline Monitoring

Construction Phase

- 2.6.1 Baseline monitoring shall be carried out at all of the designated monitoring locations for at least 14 consecutive days prior to the commissioning of the construction works to obtain daily 24-hour TSP samples. The selected baseline monitoring stations should reflect baseline conditions at the impact stations. One-hour sampling should also be done at least 3 times per day while the highest dust impact is expected.
- 2.6.2 During the baseline monitoring, there should not be any construction or dust generation activities in the vicinity of the monitoring stations. Before commencing baseline monitoring, the ET shall inform the IEC of the baseline monitoring programme such that the ER can conduct on-site audit to ensure accuracy of the baseline monitoring results.
- 2.6.3 In case the baseline monitoring cannot be carried out at the designated monitoring locations during the baseline monitoring period, the ET Leader shall carry out the monitoring at alternative

locations that can effectively represent the baseline conditions at the impact monitoring locations. The alternative baseline monitoring locations shall be approved by the ER and agreed with the IEC.

- 2.6.4 In exceptional cases, when insufficient baseline monitoring data or questionable results are obtained, the ET shall liaise with the IEC and EPD to agree on an appropriate set of data to be used as a baseline reference and submit to ER for approval.
- 2.6.5 Ambient conditions may vary seasonally and shall be reviewed once every three months. When the ambient conditions have changed and a repeat of the baseline monitoring is required to be carried out for obtaining the updated baseline levels, the monitoring should be at times when the Contractor's activities are not generating dust, at least in the proximity of the monitoring stations. Should change in ambient conditions be determined, the baseline levels and, in turn, the air quality criteria, should be revised. The revised baseline levels and air quality criteria should be agreed with the IEC and EPD.

Operation Phase

- 2.6.6 One year prior to the commissioning of the Project, a programme to monitor odour intensity / odour patrol along the monitoring route as shown in **Figure 2.3** shall be undertaken. The odour patrol will be carried out at low tide condition for capturing the potential worst odour level of that day.
- 2.6.7 The measured results at ASR will serve as the baseline data set prior to the commissioning of the Project. These will be compared with the results obtained during the impact monitoring stage.
- 2.6.8 In addition, the following information shall be obtained:
- Meteorological conditions from the nearest Hong Kong Observatory's Weather Station (including temperature, wind speed, relative humidity) during the monitoring;
 - Whether any abnormal operations were being carried out at the CBTS during the monitoring.
- 2.6.9 The baseline monitoring events shall be carried out every three months at the same location within the year before the Project commissioned. The odour record during any of low tide, hot or dry condition will be included to capture the worst case situations.

2.7 Impact Monitoring of Construction Air Quality Impact

- 2.7.1 The ET shall carry out impact monitoring during the course of the Works. For regular impact monitoring, the sampling frequency of at least once in every six-days, shall be strictly observed at all the monitoring stations for 24-hour TSP monitoring. For 1-hour TSP monitoring, the sampling frequency of at least three times in every six-days should be undertaken when the highest dust impact occurs. Before commencing baseline monitoring, the ET shall inform the IEC of the impact monitoring programme such that the IEC can conduct on-site audit to ensure accuracy of the impact monitoring results.
- 2.7.2 The specific time to start and stop the 24-hour TSP monitoring shall be clearly defined for each location and be strictly followed by the operator.
- 2.7.3 In case of non-compliance with the air quality criteria, more frequent monitoring, as specified in the Action Plan in the following section, shall be conducted within 24 hours after the result is obtained. This additional monitoring shall be continued until the excessive dust emission or the deterioration in air quality is rectified.

2.8 Impact Monitoring for Odour Patrol

2.8.1 Odour patrols along the shorelines of Causeway Bay Typhoon Shelter and ex-Wan Chai Public Cargo Working Area when there is temporary reclamation in Causeway Bay Typhoon Shelter and/or in the ex-Wan Chai Public Cargo Working Area, or when there is dredging of the odorous sediment and slime at the south-western corner of the Causeway Bay Typhoon Shelter. Odour patrols will be carried out at bi-weekly intervals during July, August and September by a qualified person of the ET who shall:

- be at least 16 years of age ;
- be free from any respiratory illnesses; and
- not be allowed to smoke, eat, drink (except water) or use chewing gum or sweets 30 min before and during odour patrol;

2.8.2 Odour patrol shall be conducted by independent trained personnel / competent persons patrolling and sniffing around the shore as shown in **Sketch A** in **Appendix L** to detect any odour at the concerned hours (afternoon is preferred for higher daily temperature).

2.8.3 The qualified person will use the nose (olfactory sensor) to sniff odours at different locations. The main odour emission sources and the areas to be affected by the odour nuisance will be identified.

2.8.4 The perceived odour intensity is to be divided into 5 levels which are ranked in the descending order as follows:

- 0 - Not detected. No odour perceived or an odour so weak that it cannot be easily characterised or described;
- 1 - Slight Identifiable odour, and slight chance to have odour nuisance;
- 2 - Moderate Identifiable odour, and moderate chance to have odour nuisance;
- 3 - Strong Identifiable, likely to have odour nuisance;
- 4 - Extreme Severe odour, and unacceptable odour level.

2.8.5 The findings including odour intensity, odour nature and possible odour sources, and also the local wind speed and direction at each location will be recorded. In addition, some relevant meteorological and tidal data such as daily average temperature, and daily average humidity, on that surveyed day will be obtained from the Hong Kong Observatory Station for reference.

2.8.6 The Action and Limit levels for odour patrol are shown in **Table 2.3**.

Table 2.3 Action / Limit Levels for Odour Patrol

Parameters	Action	Limit
Odour Nuisance (from odour intensity analysis or odour patrol)	<ul style="list-style-type: none"> • When two documented complaint are received; or • Odour Intensity of 2 is measured from odour intensity analysis. 	<ul style="list-style-type: none"> • Five or more consecutive genuine documented complaints within a week; or • Odour Intensity of 3 or above is measured from odour intensity analysis.

2.9 Impact Monitoring of Operation Air Quality Impact

- 2.9.1 Odour monitoring in the form of odour patrol shall be conducted by the CEDD¹ at the proposed monitoring route as shown in **Figure 2.3**.
- 2.9.2 The monitoring events shall be carried out during daytime and during the period of July to September on a monthly basis for two days in order to capture the likely worst case scenario of a year. The operational odour monitoring shall be carried out for a minimum of 3 years period.
- 2.9.3 The monitoring shall be carried out at low tide condition for capturing the potential worst odour level of that day and shall not be conducted on rainy days. Hourly meteorological conditions (temperature, wind speed & direction, humidity) shall be recorded throughout the monitoring period.

2.10 Environmental Quality Performance Limits

- 2.10.1 The baseline monitoring results form the basis for determining the air quality criteria for the impact monitoring. The ET shall compare the impact monitoring results with air quality criteria set up for 24-hour TSP and 1-hour TSP and odour criteria. **Table 2.4** shows the air quality criteria, namely Action and Limit levels to be used.

Table 2.4 Action / Limit Levels for Air Quality

Parameters	Action	Limit
24-hour TSP Level in $\mu\text{g m}^{-3}$	For baseline level $\leq 200 \mu\text{g m}^{-3}$, Action level = (baseline level * 1.3 + Limit level)/2; For baseline level $> 200 \mu\text{g m}^{-3}$ Action level = Limit level	$260 \mu\text{g m}^{-3}$
1-hour TSP Level in $\mu\text{g m}^{-3}$	For baseline level $\leq 384 \mu\text{g m}^{-3}$, Action level = (baseline level * 1.3 + Limit level)/2; For baseline level $> 384 \mu\text{g m}^{-3}$, Action level = Limit level	$500 \mu\text{g m}^{-3}$
Odour Nuisance (from odour intensity analysis or odour patrol)	<ul style="list-style-type: none"> When two documented complaint are received; or Odour Intensity of 2 is measured from odour intensity analysis. 	<ul style="list-style-type: none"> Five or more consecutive genuine documented complaints within a week; or Odour Intensity of 3 or above is measured from odour intensity analysis.

2.11 Event and Action Plan

- 2.11.1 Should non-compliance of the air quality criteria occur, actions in accordance with the Action Plan in **Tables 2.5, 2.6** and **2.7** shall be carried out.

¹ CEDD will identify an implementation agent.

Table 2.5 Event / Action Plan for Construction Air Quality

EVENT	ACTION			
	ET	IEC	ER	CONTRACTOR
ACTION LEVEL				
1. Exceedance for one sample	<ol style="list-style-type: none"> Identify source, investigate the causes of exceedance and propose remedial measures; Inform IEC and ER; Repeat measurement to confirm finding; Increase monitoring frequency to daily. <p>(The above actions should be taken within 2 working days after the exceedance is identified)</p>	<ol style="list-style-type: none"> Check monitoring data submitted by ET; Check Contractor's working method. <p>(The above actions should be taken within 2 working days after the exceedance is identified)</p>	<ol style="list-style-type: none"> Notify Contractor. <p>(The above actions should be taken within 2 working days after the exceedance is identified)</p>	<ol style="list-style-type: none"> Rectify any unacceptable practice; Amend working methods if appropriate. <p>(The above actions should be taken within 2 working days after the exceedance is identified)</p>
2. Exceedance for two or more consecutive samples	<ol style="list-style-type: none"> Identify source; Inform IEC and ER; Advise the ER on the effectiveness of the proposed remedial measures; Repeat measurements to confirm findings; Increase monitoring frequency to daily; Discuss with IEC and Contractor on remedial actions required; If exceedance continues, arrange meeting with IEC and ER; If exceedance stops, cease additional monitoring. <p>(The above actions should be taken within 2 working days after the exceedance is identified)</p>	<ol style="list-style-type: none"> Check monitoring data submitted by ET; Check Contractor's working method; Discuss with ET and Contractor on possible remedial measures; Advise the ET on the effectiveness of the proposed remedial measures; Supervise Implementation of remedial measures. <p>(The above actions should be taken within 2 working days after the exceedance is identified)</p>	<ol style="list-style-type: none"> Confirm receipt of notification of failure in writing; Notify Contractor; Ensure remedial measures properly implemented. <p>(The above actions should be taken within 2 working days after the exceedance is identified)</p>	<ol style="list-style-type: none"> Submit proposals for remedial to ER within 3 working days of notification; Implement the agreed proposals; Amend proposal if appropriate. <p>(The above actions should be taken within 2 working days after the exceedance is identified)</p>
LIMIT LEVEL				
1. Exceedance for one sample	<ol style="list-style-type: none"> Identify source, investigate the causes of exceedance and propose remedial measures; Inform ER, Contractor and EPD; Repeat measurement to confirm finding; Increase monitoring frequency to daily; Assess effectiveness of Contractor's remedial actions and keep IEC, EPD and ER informed of the results. <p>(The above actions should be taken within 2 working days after the exceedance is identified)</p>	<ol style="list-style-type: none"> Check monitoring data submitted by ET; Check Contractor's working method; Discuss with ET and Contractor on possible remedial measures; Advise the ER on the effectiveness of the proposed remedial measures; Supervise implementation of remedial measures. <p>(The above actions should be taken within 2 working days after the exceedance is identified)</p>	<ol style="list-style-type: none"> Confirm receipt of notification of failure in writing; Notify Contractor; Ensure remedial measures properly implemented. <p>(The above actions should be taken within 2 working days after the exceedance is identified)</p>	<ol style="list-style-type: none"> Take immediate action to avoid further exceedance; Submit proposals for remedial actions to IEC within 3 working days of notification; Implement the agreed proposals; Amend proposal if appropriate. <p>(The above actions should be taken within 2 working days after the exceedance is identified)</p>
2. Exceedance for two or more consecutive samples	<ol style="list-style-type: none"> Notify IEC, ER, Contractor and EPD; Identify source; Repeat measurement to confirm findings; Increase monitoring frequency to daily; Carry out analysis of Contractor's working procedures to determine possible mitigation to be implemented; Arrange meeting with IEC and ER to discuss the remedial actions to be taken; Assess effectiveness of Contractor's remedial actions and keep IEC, EPD and ER informed of the results; If exceedance stops, cease additional monitoring. <p>(The above actions should be taken within 2 working days after the exceedance is identified)</p>	<ol style="list-style-type: none"> Discuss amongst ER, ET, and Contractor on the potential remedial actions; Review Contractor's remedial actions whenever necessary to assure their effectiveness and advise the ER accordingly; Supervise the implementation of remedial measures. 	<ol style="list-style-type: none"> Confirm receipt of notification of failure in writing; Notify Contractor; In consolidation with the IEC, agree with the Contractor on the remedial measures to be implemented; Ensure remedial measures properly implemented; If exceedance continues, consider what portion of the work is responsible and instruct the Contractor to stop that portion of work until the exceedance is abated. <p>(The above actions should be taken within 2 working days after the exceedance is identified)</p>	<ol style="list-style-type: none"> Take immediate action to avoid further exceedance; Submit proposals for remedial actions to IEC within 3 working days of notification; Implement the agreed proposals; Resubmit proposals if problem still not under control; Stop the relevant portion of works as determined by the ER until the exceedance is abated. <p>(The above actions should be taken within 2 working days after the exceedance is identified)</p>

Table 2.6 Event/Action Plan for Odour Patrol

Event	ACTION	
	Person-in-charge of Odour Monitoring	Implementation Agent Identified by CEDD
ACTION LEVEL		
Exceedance of Action Level	<ol style="list-style-type: none"> 1. Identify source/reason of exceedance; 2. Repeat odour patrol to confirm finding. 	<ol style="list-style-type: none"> 1. Carry out investigation to identify the source/reason of exceedance; 2. Rectify any unacceptable practice 3. Implement more mitigation measures if necessary; 4. Inform EPD or MD if exceedance is considered to be caused by expedient connections or floating debris.
LIMIT LEVEL		
Exceedance of Limit Level	<ol style="list-style-type: none"> 1. Identify source / reason of exceedance; 2. Repeat odour patrol to confirm findings; 3. Increase odour patrol frequency; 4. If exceedance stops, cease additional odour patrol. 	<ol style="list-style-type: none"> 1. Carry out investigation to identify the source/reason of exceedance. Investigation shall be completed within 2 weeks; 2. Rectify any unacceptable practice; 3. Formulate remedial actions; 4. Ensure remedial actions properly implemented; 5. If exceedance continues, consider what more/enhanced mitigation measures shall be implemented; 6. Inform EPD or MD if exceedance is considered to be caused by expedient connections or floating debris.

Table 2.7 Event/Action Plan for Operation Air Quality Monitoring

EVENT	ACTION	
	Person-in-charge of Odour Monitoring	CEDD ²
ACTION LEVEL		
Exceedance of action level	<ol style="list-style-type: none"> 1. Identify source/reason of exceedance; 2. Repeat odour patrol to confirm finding. 	<ol style="list-style-type: none"> 1. Carry out investigation to identify the source/reason of exceedance. Investigation shall be completed within 2 week; 2. Rectify any unacceptable practice; 3. Implement more mitigation measures if necessary; 4. Inform EPD or MD if exceedance is considered to be caused by expedient connections or floating debris.

² CEDD will identify an implementation agent.

EVENT	ACTION	
	Person-in-charge of Odour Monitoring	CEDD ²
LIMIT LEVEL		
Exceedance of Limit level	<ol style="list-style-type: none"> 1. Identify source / reason of exceedance; 2. Repeat odour patrol to confirm findings; 3. Increase odour patrol frequency to bi-weekly; 4. If exceedance stops, cease additional odour patrol. 	<ol style="list-style-type: none"> 1. Carry out investigation to identify the source/reason of exceedance. Investigation shall be completed within 2 week; 2. Rectify any unacceptable practice; 3. Formulate remedial actions; 4. Ensure remedial actions properly implemented; 5. If exceedance continues, consider what more/enhanced mitigation measures shall be implemented; 6. Inform EPD or MD if exceedance is considered to be caused by expedient connections or floating debris.

2.12 Mitigation Measures

Construction Phase

- 2.12.1 As described in the EIA Report, the ASRs from Central to Causeway Bay would comply with AQO and EIAO-TM criteria during construction phase of each Designated Projects.
- 2.12.2 The findings of the EIA also indicated that potential odour impacts from contaminated sediment would be expected when the dredging activities carrying out in the vicinity of Police Officers' Club. For the dredging activities carrying out in the vicinity of Police Officers' Club, the dredging operation will be restricted to only 1 small close grab dredger to minimise the odour impact during the dredging activity. The dredging rate should be reduced as much as practicable for area in close proximity to the Police Officers' Club. Grab dredger has to be used for filling up the geosynthetic containers on barges. As there is no constraint on the programme for the removal of the sediments at the south-west corner of the typhoon shelter in the vicinity of Police Officers' Club, the dredging rate can be slowed down or restricted to specific non-popular hours in weekdays when it is necessary during construction.
- 2.12.3 If the above measures are not sufficient to restore the air quality to acceptable levels upon the advice of ET Leader, the Contractor shall liaise with the ET Leader on some other mitigation measures, propose to ER for approval, and implement the mitigation measures.

Operation Phase

- 2.12.4 Existing odour pollution sources would have potential odour impact on the planned ASR. The following mitigation measures are recommended to be implemented to reduce the odour impact in future.
- Carry out dredging at the corner of CBTS to remove the contaminated sediment
 - Clean the slime attached on the shoreline seawall during the construction of the Project
 - Implementation of "Enhancement Package for Existing Odour Sources Identified at Causeway Bay Typhoon Shelter" including rectification of expedient connection to stormwater outfalls P and Q
- 2.12.5 The implementation schedule for the mitigation measures during construction phase and operation phase is presented in **Appendix A**.

CONTENTS

3	NOISE	3-1
3.1	Introduction	3-1
3.2	Noise Parameters.....	3-1
3.3	Monitoring Equipment	3-1
3.4	Monitoring Locations.....	3-2
3.5	Baseline Monitoring.....	3-3
3.6	Impact Monitoring.....	3-3
3.7	Event and Action Plan.....	3-5
3.8	Noise Mitigation Measures	3-5

LIST OF TABLES

Table 3.1	Locations of Noise Monitoring Stations during Construction Phase
Table 3.2	Division of Noise Monitoring Stations for contracts with construction work commenced/to be commenced in 2010
Table 3.2a	Locations of Real-time Noise Monitoring Stations during Construction Phase
Table 3.3	Action and Limit Levels for Construction Noise
Table 3.4	Event/Action Plan for Construction Noise

LIST OF FIGURES

Figure 3.1	Locations of Representative Noise Sensitive Receivers
Figure 3.2	Locations of Construction Noise Monitoring Stations

LIST OF APPENDICES

Appendix A	Implementation Schedule of Recommended Mitigation Measures
Appendix B	Data Record Sheet
Appendix M	Details of real-time noise monitoring system

3 NOISE

3.1 Introduction

- 3.1.1 In this section, the general requirements, methodology, equipment, and mitigation measures for the monitoring and audit of noise impacts associated with the construction and operation phase of the Designated Projects are described below.
- 3.1.2 Construction noise impacts arising from DP3 and DP5 are predicted at the identified NSRs. Noise mitigation measures would be required to reduce noise levels to the stipulated standard. A noise monitoring programme shall be undertaken to ensure such mitigation measures would be implemented properly.
- 3.1.3 The proposed cross harbour water mains will extend from Wan Chai near the HKCEC Extension to connect to the existing system near the Museum of Arts at the Tsim Sha Tsui promenade. The noise sensitive receivers located within 300m of construction sites at Wan Chai and Tsim Sha Tsui are basically the buildings equipped with central air-conditioning system. The first layer of NSRs near Tsim Sha Tsui site, which are centrally air-conditioned, would provide considerable acoustic shielding to those receivers at further distance behind. No adverse noise impact would be anticipated and therefore noise monitoring would not be required for DP6. However, weekly site inspection shall be carried out throughout the construction phase to ensure that appropriate noise control measures would be properly implemented with a view to minimizing the construction noise impact.

3.2 Noise Parameters

Construction Phase

- 3.2.1 The construction noise level shall be measured in terms of the A-weighted equivalent continuous sound pressure level (L_{eq}). $L_{eq(30\text{ minutes})}$ shall be used as the monitoring parameter for the time period between 0700 and 1900 hours on normal weekdays. For all other time periods, $L_{eq(5\text{ minutes})}$ shall be employed for comparison with the Noise Control Ordinance (NCO) criteria.
- 3.2.2 Supplementary information for data auditing, statistical results such as L_{10} and L_{90} shall also be obtained for reference. A sample data record sheet based on the one presented in the *EM&A Guidelines for Development Projects in Hong Kong* is shown in **Appendix B**. The ET Leader may modify the data record sheet for this EM&A programme, of which the format should be agreed by the ER and the IEC.
- 3.2.3 The locations of representative noise sensitive receivers within the Study Area of the Designated Projects are shown in **Figure 3.1**.

Operation Phase

- 3.2.4 The DP3, DP5 and DP6 will not generate vehicular traffic in the operation phase and hence traffic noise monitoring for the operation phase is not required in this EM&A Manual.

3.3 Monitoring Equipment

- 3.3.1 As referred to in the Technical Memorandum (TM) issued under the NCO, sound level meters in compliance with the International Electrotechnical Commission Publications 651: 1979 (Type 1) and 804: 1985 (Type 1) specifications shall be used for carrying out the noise monitoring. Immediately prior to and following each noise measurement the accuracy of the sound level meter shall be checked using an acoustic calibrator generating a known sound pressure level at a known frequency. Measurements may be accepted as valid only if the calibration level from before and after the noise measurement agree to within 1.0 dB.

- 3.3.2 Noise measurements shall not be made in fog, rain, wind with a steady speed exceeding 5 m s^{-1} or wind with gusts exceeding 10 m s^{-1} . The wind speed shall be checked with a portable wind speed meter capable of measuring the wind speed in m s^{-1} .
- 3.3.3 The ET is responsible for the provision of the monitoring equipment. He shall ensure that sufficient noise measuring equipment and associated instrumentation are available for carrying out the baseline monitoring, regular impact monitoring and ad hoc monitoring. All the equipment and associated instrumentation shall be clearly labelled.

3.4 Monitoring Locations

- 3.4.1 The locations of noise monitoring stations during construction phase of the Designated Projects are presented in **Table 3.1** and only the proposed locations are shown in **Figure 3.2**.

Table 3.1 Locations of Noise Monitoring Stations during Construction Phase

Noise Monitoring Station	Noise Monitoring Location	Level (in terms of no. of floor)
M1a	Harbour Road Sports Centre	3/F (roof-top)
M2b	Noon Gun Area	G/F
M3a	Tung Lo Wan Fire Station	3/F (roof-top)
M4b	Victoria Centre	2/F
M5b	Between Block 6 and 7, City Garden	G/F

The status and locations of the noise sensitive receivers may change after issuing this Manual. If such cases exist, the ET Leader shall propose updated monitoring locations and seek approval from the ER and agreement from the IEC

Commencement of Noise Monitoring Programme in Stages

- 3.4.2 As per the condition 2.5(d) under EP-356/2009, environmental monitoring and the execution of Event & Action Plan (EAP) are considered based on taken into account of the latest works schedules, division of responsibilities among different contracts in the Project, and latest project information. Division of work areas under different contracts will be managed under separate FEPs applied by individual contractors.
- 3.4.3 In terms of division of work areas, the proposed division of noise monitoring stations and its commencement in stages are summarized in **Table 3.2**.

Table 3.2 Division of Noise Monitoring Stations for contracts with construction work commenced/to be commenced in 2010 and 2011

Contract No.	Associated DP(s)	Relevant Noise Monitoring Stations ¹	Commencement of monitoring w.r.t construction commencement
HY/2009/11	DP3	M4b, M5b	Mar 2010
HK/2009/01	DP3, DP6	M1a	Jul 2010

Contract No.	Associated DP(s)	Relevant Noise Monitoring Stations¹	Commencement of monitoring w.r.t construction commencement
HK/2009/02	DP3, DP5	M1a	Jul 2010
HY/2009/15	DP3	M2b, M3a	Sep 2010
HK/2010/06	DP3	M1a	Apr 2011

3.5 Baseline Monitoring

Construction Phase

- 3.5.1 The ET shall carry out baseline noise monitoring prior to the commencement of the construction works. The baseline monitoring shall be carried out daily for a period of at least two weeks. Before commencing the baseline monitoring, the ET shall develop and submit to the IEC the baseline monitoring programme such that the IEC can conduct on-site audit to ensure accuracy of the baseline monitoring results.
- 3.5.2 There shall not be any construction activities in the vicinity of the stations during the baseline monitoring.
- 3.5.3 In exceptional cases, when insufficient baseline monitoring data or questionable results are obtained, the ET Leader shall liaise with the ER, EPD and IEC to agree on an appropriate set of data to be used as a baseline reference and submit to the ER and IEC for agreement and EPD for approval.

Operation Phase

- 3.5.4 No baseline operation noise monitoring is generally required.

3.6 Impact Monitoring

Construction Phase

- 3.6.1 Noise monitoring shall be carried out at all the designated monitoring stations. The monitoring frequency shall depend on the scale of the construction activities. The following is an initial guide on the regular monitoring frequency for each station on a weekly basis when noise generating activities are underway:
- (a) one set of measurements between 0700 and 1900 hours on normal weekdays.
- 3.6.2 A real-time on-site monitoring system of the noise level around the works sites at North Point and Tin Hau areas should be carried out during the construction phase. The detailed monitoring system is presented as follows and **Appendix M**.

- (a) Instrumentation
- Sound level meter in compliance with the International Electrotechnical Commission Publications 651: 1979 (Type 1) and 804: 1985 (Type 1) specifications shall be used for carrying out the noise monitoring.
 - Capable of giving continuous readout of the noise level readings including equivalent continuous sound pressure level (L_{eq}) and 10th and 90th percentile of sound level pressure level (L_{10} & L_{90}).
- (b) Methodology
- A weatherproof enclosure shall be installed to protect the sound level meter and the communications hardware from sunlight and rain. This enclosure shall be mounted against the handrail and bolted on the wall if necessary.
 - Noise monitoring shall be automatically conducted for 24 hours a day. Data will be instantaneously transmitted to a central office through the use of communication hardware and software.
 - Power supply shall be provided for the real-time noise monitoring system.
- (c) Measurement Location

Table 3.2a Locations of Real-time Noise Monitoring Stations during Construction Phase

Real-time Noise Monitoring Station	Noise Monitoring Location (District)	Level (in terms of no. of floor)
RTN1	Tung Lo Wan Fireboat Station (Tin Hau)	3/F (roof-top)
RTN2	Oil Street Community Liaison Centre (North Point)	1/F (roof-top)

- (d) Calibration of equipment
- The sound level meter shall be checked using an acoustic calibrator generating a known sound pressure level at a known frequency before deployment to the site and during each site visit. Measurements may be accepted as valid only if the calibration level from before and after the noise measurement agree to within 1.0 dB.
- (e) Data Reporting
- An electronic system shall be set-up to track, manage and data reporting, as well as automatic compliance assessment.
 - The electronic system shall also report the instantaneous monitoring results on a dedicated website.
 - The current practice on the noise screening is via adjustment by ET and IEC. This will be the additional measures to avoid erroneous noise data.

3.6.3 If construction works are extended to include works during the hours of 1900 – 0700 as well as public holidays and Sundays, additional weekly impact monitoring shall be carried out during respective restricted hours periods. Applicable permits under NCO shall be obtained by the Contractor.

3.6.4 If a school exists near the construction activity, noise monitoring shall be carried out at the monitoring stations for the schools during the school examination periods. The ET Leader shall liaise with the school's personnel and the Examination Authority to ascertain the exact dates and times of all examination periods during the course of the contract.

- 3.6.5 In case of non-compliance with the construction noise criteria, more frequent monitoring, as specified in the Action Plan in **Table 3.2**, shall be carried out. This additional monitoring shall be continued until the recorded noise levels are rectified or demonstrated to be unrelated to the construction activities.

Operation Phase

- 3.6.6 The DP3, DP5 and DP6 will not generate vehicular traffic in the operation phase and hence traffic noise monitoring for the operation phase is not required under this EM&A Manual.

3.7 Event and Action Plan

Construction Phase

- 3.7.1 The Action and Limit levels for construction noise are defined in **Table 3.3**. Should non-compliance of the criteria occur, action in accordance with the Event and Action Plan in **Table 3.4** shall be implemented.

Table 3.3 Action and Limit Levels for Construction Noise

Time Period	Action Level	Limit Level
0700 – 1900 hours on normal weekdays	When one documented complaint is received	75 dB(A) *

Notes: If works are to be carried out during restricted hours, the conditions stipulated in the Construction Noise Permit (CNP) issued by the Noise Control Authority have to be followed.

* : 70 dB(A) and 65 dB(A) for schools during normal teaching periods and school examination periods, respectively.

Operation Phase

- 3.7.2 The DP3, DP5 and DP6 will not generate vehicular traffic in the operation phase and hence traffic noise monitoring for the operation phase is not required under this EM&A Manual.

3.8 Noise Mitigation Measures

Construction Phase

- 3.8.1 The EIA has recommended noise control and mitigation measures during the construction and operation phases of the Project. In the event of exceedances or complaints, the Contractor shall be responsible for the design and implementation of these measures which are outlined in Implementation Schedule in **Appendix A**.

- 3.8.2 The Contractor is recommended to adopt quiet powered mechanical equipment (PME) for the following construction tasks of the Designated Projects DP3, DP5 and DP6:

- Temporary seawall construction, filling behind seawall, for whole project construction
- Temporary diversion of cooling water pipeline at CBTS 4
- Demolition of structure
- Drainage culverts construction

- Ferry pier reprovisioning, including construction of new ferry pier and demolition of existing structure
- WSD's salt water pumping station construction
- Construction of Wan Chai East sewage outfall
- Road works construction
- MTR Tunnel crossing
- Cross harbour watermains

3.8.3 To alleviate the construction noise impact on the affected NSRs, two types of noise barriers (movable and temporary noise barriers during construction) are proposed to be provided for particular items of plant and construction works. The Contractor is recommended to adopt movable noise barriers with a cantilevered upper portion for the following items of plant:

- Excavator
- Bentonite Plants
- Poker Vibrator
- Diaphragm Wall Rigs
- Generator
- Air Compressor
- Concrete Pump
- Hand-held Breaker
- Breaker

3.8.4 There are also many good site practices recommended as follows:

- Only well-maintained plant shall be operated on-site and plant shall be serviced regularly during the construction program.
- Silencers or mufflers on construction equipment shall be utilised and shall be properly maintained during the construction program.
- Mobile plant, if any, shall be sited as far away from NSRs as possible.
- Machines and plant (such as trucks) that may be in intermittent use shall be shut down between works periods or shall be throttled down to a minimum.
- Plant known to emit noise strongly in one direction shall, wherever possible, be orientated so that the noise is directed away from the nearby NSRs.
- Material stockpiles and other structures shall be effectively utilised, wherever practicable, in screening noise from on-site construction activities.

3.8.5 If the above measures are not sufficient to restore the construction noise quality to acceptable levels upon the advice of ET Leader, the contractor shall liaise with the ET Leader to identify further mitigation measures. They shall be proposed to ER for approval, and the contractor shall then implement these additional mitigation measures.

Operation Phase

3.8.6 The DP3, DP5 and DP6 will not generate vehicular traffic in the operation phase and hence operation phase noise mitigation measures are not required under this EM&A Manual.

Table 3.4 Event/Action Plan for Construction Noise

EVENT	ACTION			
	ET	IEC	ER	CONTRACTOR
<p>Action Level being exceeded</p>	<ol style="list-style-type: none"> 1. Notify ER, IEC and Contractor; 2. Carry out investigation; 3. Report the results of investigation to the IEC, ER and Contractor; 4. Discuss with the IEC and Contractor on remedial measures required; 5. Increase monitoring frequency to check mitigation effectiveness. <p>(The above actions should be taken within 2 working days after the exceedance is identified)</p>	<ol style="list-style-type: none"> 1. Review the investigation results submitted by the ET; 2. Review the proposed remedial measures by the Contractor and advise the ER accordingly; 3. Advise the ER on the effectiveness of the proposed remedial measures. <p>(The above actions should be taken within 2 working days after the exceedance is identified)</p>	<ol style="list-style-type: none"> 1. Confirm receipt of notification of failure in writing; 2. Notify Contractor; 3. In consolidation with the IEC, agree with the Contractor on the remedial measures to be implemented; 4. Supervise the implementation of remedial measures. <p>(The above actions should be taken within 2 working days after the exceedance is identified)</p>	<ol style="list-style-type: none"> 1. Submit noise mitigation proposals to IEC and ER; 2. Implement noise mitigation proposals. <p>(The above actions should be taken within 2 working days after the exceedance is identified)</p>

EVENT	ACTION			
	ET	IEC	ER	CONTRACTOR
Limit Level being exceeded	<ol style="list-style-type: none"> 1. Inform IEC, ER, Contractor and EPD; 2. Repeat measurements to confirm findings; 3. Increase monitoring frequency; 4. Identify source and investigate the cause of exceedance; 5. Carry out analysis of Contractor's working procedures; 6. Discuss with the IEC, Contractor and ER on remedial measures required; 7. Assess effectiveness of Contractor's remedial actions and keep IEC, EPD and ER informed of the results; 8. If exceedance stops, cease additional monitoring. <p>(The above actions should be taken within 2 working days after the exceedance is identified)</p>	<ol style="list-style-type: none"> 1. Discuss amongst ER, ET, and Contractor on the potential remedial actions; 2. Review Contractor's remedial actions whenever necessary to assure their effectiveness and advise the ER accordingly. <p>(The above actions should be taken within 2 working days after the exceedance is identified)</p>	<ol style="list-style-type: none"> 1. Confirm receipt of notification of failure in writing; 2. Notify Contractor; 3. In consolidation with the IEC, agree with the Contractor on the remedial measures to be implemented; 4. Supervise the implementation of remedial measures; 5. If exceedance continues, consider stopping the Contractor to continue working on that portion of work which causes the exceedance until the exceedance is abated. <p>(The above actions should be taken within 2 working days after the exceedance is identified)</p>	<ol style="list-style-type: none"> 1. Take immediate action to avoid further exceedance; 2. Submit proposals for remedial actions to IEC and ER within 3 working days of notification; 3. Implement the agreed proposals; 4. Submit further proposal if problem still not under control; 5. Stop the relevant portion of works as instructed by the ER until the exceedance is abated. <p>(The above actions should be taken within 2 working days after the exceedance is identified)</p>

CONTENTS

4	WATER QUALITY	4-1
4.1	Water Quality Parameters.....	4-1
4.2	Monitoring Equipment.....	4-1
4.3	Laboratory Measurement / Analysis	4-2
4.4	Monitoring Locations.....	4-3
4.5	Baseline Monitoring	4-4
4.6	Impact Monitoring	4-5
4.7	Post-construction Monitoring.....	4-7
4.8	Field Log	4-7
4.9	Construction Site Audits.....	4-7
4.10	Event and Action Plan for Construction Water Quality	4-8
4.11	Mitigation of Adverse Environmental Impacts.....	4-10

LIST OF TABLES

Table 4.1	Analytical Methods to be applied to Marine Water Quality Samples
Table 4.1a	Division of Water Monitoring Stations for contracts with construction work commenced/to be commenced in 2010
Table 4.2	Proposed Marine Water Quality Monitoring Frequency and Parameters
Table 4.3	Action / Limit Levels for Dissolved Oxygen
Table 4.4	Action and Limit Levels for Marine Water Quality at Seawater Intakes
Table 4.5	The Proposed Action and Limit Levels (Dry Seasons) and Calculated Action and Limit Levels (Wet Seasons) for water quality monitoring
Table 4.6	Event and Action Plan for Marine Water Quality

LIST OF FIGURES

Figure 4.1a	Locations of Water Quality Monitoring Stations (Sheet 1 of 2)
Figure 4.1b	Locations of Water Quality Monitoring Stations (Sheet 2 of 2)
Figure 4.1c	Layout plan for Scope of Works for each of the Contracts and Water Quality Monitoring Stations

LIST OF APPENDICES

Appendix A	Implementation Schedule of Recommended Mitigation Measures
Appendix B	Data Record Sheet
Appendix D	Establishment of Seasonal Action and Limit Levels

4 WATER QUALITY

4.1 Water Quality Parameters

- 4.1.1 As identified in the EIA Report, the key water quality impacts caused by the Project would be associated with the dredging works during the construction phase. The EIA report has identified that suspended sediment is the most critical water quality parameter caused by the dredging works. Marine water quality monitoring shall be carried out during the construction phase to ensure that any unacceptable increase in suspended solids / turbidity and decrease in dissolved oxygen due to dredging activities could be readily detected and timely action be taken to rectify the situation. As presented in the EIA Report, adverse impacts associated with the potential release of contaminants (such as heavy metal and nutrients) from the marine mud during dredging activities is not expected as demonstrated by the elutriate tests and mathematical modelling. Thus, monitoring for other parameters such as heavy metal and nutrients are not considered necessary.
- 4.1.2 Dissolved oxygen (DO), turbidity and suspended solids (SS) levels shall be monitored at designated marine water quality monitoring stations during the construction phase. DO and turbidity should be measured *in situ* whereas SS should be determined by laboratory.

4.2 Monitoring Equipment

Dissolved Oxygen and Temperature Measuring Equipment

- (i) The instrument should be a portable and weatherproof dissolved oxygen (DO) measuring instrument complete with cable and sensor, and use a DC power source. The equipment should be capable of measuring:
- a DO level in the range of 0 - 20 mg L⁻¹ and 0 - 200% saturation; and
 - a temperature of 0 - 45 degree Celsius.
- (ii) It should have a membrane electrode with automatic temperature compensation complete with a cable.
- (iii) Should salinity compensation not be built-in to the DO equipment, *in-situ* salinity should be measured to calibrate the DO equipment prior to each DO measurement.

Turbidity Measurement Instrument

- 4.2.1 The instrument should be a portable and weatherproof turbidity measuring instrument using a DC power source. It should have a photoelectric sensor capable of measuring turbidity between 0 - 1000 NTU (for example, Hach model 2100P or an approved similar instrument).

Sampler

- 4.2.2 A water sampler is required. It should comprise a transparent PVC cylinder, with a capacity of not less than 2 litres, which can be effectively sealed with latex cups at both ends. The sampler should have a positive latching system to keep it open and prevent premature closure until released by a messenger when the sampler is at the selected water depth (for example, Kahlsico Water Sampler or an approved similar instrument).

Water Depth Detector

- 4.2.3 A portable, battery-operated echo sounder should be used for the determination of water depth at each designated monitoring station. This unit can either be hand held or affixed to the bottom of the work boat, if the same vessel is to be used throughout the monitoring programme.

Salinity

- 4.2.4 A portable salinometer capable of measuring salinity in the range of 0 - 40 parts per thousand (ppt) should be provided for measuring salinity of the water at each monitoring location.

Sample Containers and Storage

- 4.2.5 Water samples for SS should be stored in high density polythene bottles with no preservative added, packed in ice (cooled to 4°C without being frozen) and delivered to the laboratory and analysed as soon as possible after collection. Sufficient volume of samples should be collected to achieve the detection limit stated in **Table 4.1**.

Monitoring Position Equipment

- 4.2.6 A hand-held or boat-fixed type digital Differential Global Positioning System (DGPS) with way point bearing indication and Radio Technical Commission for maritime (RTCM) Type 16 error message 'screen pop-up' facilities (for real-time auto-display of error messages and DGPS corrections from the Hong Kong Hydrographic Office), or other equipment instrument of similar accuracy, should be provided and used during marine water monitoring to ensure the monitoring vessel is at the correct location before taking measurements.

Calibration of In-Situ Instruments

- 4.2.7 The pH meter, DO meter and turbidimeter shall be checked and calibrated before use. DO meter and turbidimeter shall be certified by a laboratory accredited under HOKLAS or any other international accreditation scheme, and subsequently re-calibrated at 3 monthly intervals throughout all stages of the water quality monitoring. Responses of sensors and electrodes should be checked with certified standard solutions before each use. Wet bulb calibration for a DO meter shall be carried out before measurement at each monitoring location.
- 4.2.8 Sufficient stocks of spare parts shall be maintained for replacements when necessary. Backup monitoring equipment shall also be made available so that monitoring can proceed uninterrupted even when some equipment is under maintenance, calibration, etc.

4.3 Laboratory Measurement / Analysis

- 4.3.1 Duplicate samples from each independent sampling event are required by EPD for all parameters. Analysis of suspended solids shall be carried out in a HOKLAS or other international accredited laboratory. Sufficient water samples shall be collected at the monitoring stations for carrying out the laboratory SS determinations, with detection limit shown in **Table 4.1**. The SS determination work shall start within 24 hours after collection of the water samples. The analyses shall follow the standard methods according to **Table 4.1** and as described in American Public Health Association (APHA) Standard Methods for the Examination of Water and Wastewater, 19th edition, unless otherwise specified.

Table 4.1 Analytical Methods to be applied to Marine Water Quality Samples

Determinant	Standard Method	Detection Limit
Suspended solids (mg L ⁻¹)	APHA 2540 D	0.1 mg L ⁻¹

- 4.3.2 If a site laboratory is set up or a non-HOKLAS and non-international accredited laboratory is hired for carrying out the laboratory analysis, the laboratory equipment, analytical procedures, and quality control shall be approved by EPD. All the analysis shall be witnessed by the ER. The ET Leader shall provide the ER with one copy of the relevant chapters of the “APHA Standard Methods for the Examination of Water and Wastewater” 19th edition and any other relevant document for his reference.
- 4.3.3 For the test methods of other parameters as recommended by EIA or required by DEP, detailed testing methods, pre-treatment procedures, instruments use, QA/QC details (such as blank, spike recovery, number of duplicate samples per batch, etc.), detection limit and accuracy shall be submitted to EPD for approval prior to the commencement of monitoring programme. The QA/QC shall be in accordance with the requirements of HOKLAS or international accredited scheme. The QA/QC results shall be reported. EPD may also request the laboratory to carry out analysis of known standards provided by EPD for quality assurance. Additional duplicate samples may be required by EPD for inter laboratory calibration. Remaining samples after analysis shall be kept by the laboratory for 3 months in case repeat analysis is required. If in-house or non-standard methods are proposed, details of the method verification may also be required to submit to EPD. In any circumstance, the sample testing shall have comprehensive quality assurance and quality control programmes. The laboratory shall prepare to demonstrate the programme to DEP or his representatives when requested.

4.4 Monitoring Locations

- 4.4.1 The locations of water monitoring stations during construction phases of the Designated Projects are shown in **Figure 4.1a** and **Figure 4.1b**. The status and locations of the water sensitive receivers may change after issuing this Manual. If such cases exist, the ET Leader shall propose updated monitoring locations and seek approval from the ER and agreement from the IEC.

Commencement of Water Quality Monitoring Programme in Stages

- 4.4.2 As per the condition 2.5(d) under EP-356/2009, water quality monitoring and the execution of Event & Action Plan (EAP) are considered based on taken into account of the latest works schedules, division of responsibilities among different contracts in the Project, and latest project information. Division of work areas under different contracts will be managed under separate FEPs applied by individual contractors.
- 4.4.3 In terms of division of work areas, the proposed division of water quality monitoring stations and its commencement in stages are summarized in **Table 4.1a**. The scope of work of each Contracts with the water monitoring stations are shown in **Figure 4.1c**

Table 4.1a Division of Water Monitoring Stations for contracts with construction work commenced/to be commenced in 2010 and 2011

Contract No.	Associated DP(s)	Relevant Water Monitoring Stations¹	Commencement of WQM w.r.t construction commencement
HY/2009/11	DP3	WSD9, WSD10, WSD15, WSD17, C8, C9	Mar 2010
HK/2009/01	DP3, DP6	WSD7, WSD19, WSD20, C1, C2, C3, C4	Jul 2010 (DP3 only)
HK/2009/02	DP3, DP5	WSD21, C5	Jun 2010 (DP3 only)
HY/2009/15	DP3	C6, C7	Nov 2010
HK/2010/06	DP3	C2	Apr 2011

Note 1: The water monitoring stations for the dredging works under Contract No. HK/2009/01 should also include WSD9, WSD17, WSD21 and C5 if water quality monitoring at these locations have not been carried out by others. Similarly, the water monitoring stations for the dredging works under Contract No. HK/2009/02 should also include WSD7, WSD9, WSD17, WSD19, C1, C2, C3 and C4 if water quality monitoring at these locations have not been carried out by others.

- 4.4.4 Based on the review of the early stage of dredging commencement (i.e. prior to commencement of DP5 & DP6), it is anticipated that only coastal dredging activities (referred as DP3) will commence and localized impact is predicted rather than the worst case scenario as indicated in the EIA report. As such, commencement of water quality monitoring in phase with respect to individual contracts will be a reasonable approach for the early commencement of water quality monitoring according to paragraph 5.6.73 of the EIA Report.

4.5 Baseline Monitoring

- 4.5.1 Baseline conditions for marine water quality should be established and agreed with EPD prior to the commencement of marine works. The purpose of the baseline monitoring is to establish ambient conditions prior to the commencement of the dredging works and to demonstrate the suitability of the proposed monitoring stations.
- 4.5.2 The baseline conditions should be established by measuring dissolved oxygen, turbidity and suspended solids levels at the selected monitoring stations as shown in **Figure 4.1a** and **Figure 4.1b** respectively. The baseline monitoring schedule should be submitted to EPD at least 2 weeks before commencement of monitoring for agreement. EPD should also be notified immediately for any changes in schedule.
- 4.5.3 The measurements should be taken at all designated monitoring stations, 3 days per week, at mid-flood and mid-ebb tides, for at least 4 weeks prior to the commencement of dredging works. Any marine construction works should be avoided in the vicinity of the stations during the baseline monitoring. The interval between 2 sets of monitoring should not be less than 36 hours. Duplicate in-situ measurements and water sampling should be carried out in each sampling event. For selection of tides for in-situ measurement and water sampling, tidal range of individual flood and ebb tides should be not less than 0.5 m.

4.6 Impact Monitoring

- 4.6.1 During the period of marine construction works, monitoring should be undertaken three days per week, at mid-flood and mid-ebb tides, with sampling/measurement at the designated monitoring stations as shown in **Table 4.2**. The interval between two sets of monitoring should not be less than 36 hours except where there are exceedances of Action and/or Limit levels, in which case the monitoring frequency will be increased. **Table 4.2** shows the proposed monitoring frequency and water quality parameters. Duplicate in-situ measurements and water sampling should be carried out in each sampling event. For selection of tides for *in-situ* measurement and water sampling, tidal range of individual flood and ebb tides should be not less than 0.5 m.

Table 4.2 Proposed Marine Water Quality Monitoring Frequency and Parameters

Activities	Monitoring Frequency ^{Note 1}	Key Parameters ^{Note 2}
During the 4-week baseline monitoring period	Three days per week, at mid-flood and mid-ebb tides	Turbidity, Suspended Solids (SS), Dissolved Oxygen (DO), pH, temperature, salinity
During marine construction works	Three days per week, at mid-flood and mid-ebb tides	Turbidity, Suspended Solids (SS), Dissolved Oxygen (DO), pH, temperature, salinity
After completion of marine construction works	Three days per week, at mid-flood and mid-ebb tides	Turbidity, Suspended Solids (SS), Dissolved Oxygen (DO), pH, temperature, salinity

Notes:

1. For selection of tides for in-situ measurement and water sampling, tidal range of individual flood and ebb tides should be not less than 0.5 m.
 2. Turbidity should be measured in situ whereas SS should be determined by laboratory.
- 4.6.2 The proposed water quality monitoring schedule should be passed to EPD at least 1 week before the first day of the monitoring. EPD should also be notified immediately for any changes in schedule. If the monitoring data collected at the flushing water intakes indicate that the Action or Limit levels as shown in **Table 4.4** are exceeded, appropriate actions should be taken to stop the dredging works and mitigation measures such as slowing down, or rescheduling of works should be implemented as necessary. A turbidity meter should be installed at the intake of Wan Chai Salt Water Pumping Station so that WSD can check the turbidity any time and take remedial measures if the limits as shown in **Table 4.4** are exceeded.

Enhanced water quality monitoring and audit programme

- 4.6.3 The enhanced water quality monitoring and audit programme to avoid aggravation of odour nuisance from seawater arising from temporary reclamation in the ex-Wan Chai Public Cargo Working Area and the Causeway Bay Typhoon Shelter will include the following (refer to **Sketch A** in **Appendix L** for locations of monitoring stations):
- monitoring of the dissolved oxygen at the two seawater intakes C6 and C7 in Causeway Bay Typhoon Shelter when there is temporary reclamation in Causeway Bay Typhoon Shelter.
 - monitoring of the dissolved oxygen at the south-western and south-eastern corners of the ex-Wan Chai Public Cargo Working Area (station ref.: Ex-WPCWA-SW & Ex-WPCWA-SE) when there is temporary reclamation in the ex-Wan Chai Public Cargo Working Area.
 - monitoring of dissolved oxygen in (a) and (b) above are to be carried out 3 days per week, at mid-flood and mid-ebb tides for 3 water depths (1m below water surface, mid-depth and 1m above sea bed, except where the water depth less than 6m, the mid-depth may be omitted. If the water depth be less than 3m, only the mid-depth will be monitored).
 - Odour patrols along the shorelines of Causeway Bay Typhoon Shelter and ex-Wan Chai Public Cargo Working Area when there is temporary reclamation in Causeway Bay Typhoon Shelter and/or in the ex-Wan Chai Public Cargo Working Area, or when there is dredging of the odorous sediment and slime at the south-western corner of the Causeway Bay Typhoon Shelter (odour patrol routes as illustrated in the **Sketch A** in **Appendix L**). The details of requirements for the odour patrol can be referred to the Section 2.8.
- 4.6.4 The Action and Limit levels for dissolved oxygen are shown in **Table 4.3**.

Table 4.3 Action / Limit Levels for Dissolved Oxygen

Parameters	Action Level	Limit Level
Dissolved Oxygen (DO) in mg/L	5 percentile of baseline data or < 2.1 mg/L	1 percentage of baseline data or < 2 mg/L

Remarks: The baseline data refer to the data obtained from the supplementary baseline DO monitoring conducted in May 2010 to June 2010. The Event/Action Plan for the monitoring of DO under the enhanced water quality monitoring and audit programme can be referred to Table 4.6.

Suspended Solids and Turbidity Monitoring during Dredging

- 4.6.5 During dredging of the sediment at the south-western corner of the Causeway Bay Typhoon Shelter, daily monitoring of suspended solids and 24 hour monitoring of turbidity at the cooling water intakes (C6 and C7) will be carried out (Sketch A in **Appendix L** for locations of C6 and C7). The 24 hours monitoring of turbidity at the cooling water intakes (C6 and C7) can be established by setting up a continuous water quality monitoring station in front of the intakes during the dredging activities. The monitoring system will include the turbidity sensor and data logger which is capable of data capturing at every 5 minutes. The data will be downloaded daily and compared with the Action and Limit level determined during the baseline water quality monitoring at the cooling water intake locations.

Regular Maintenance of Silt Screens

4.6.6 Silt screens are recommended to be deployed at selected WSD flushing water intakes during the marine works period. The operation of the flushing water intakes would not be adversely affected by the silt screens provided that the silt screens are properly designed and maintained. Installation of silt screens at the selected flushing water intake points shall be implemented by the contractor for the marine works. The contractor shall demonstrate and ensure that the design of the silt screen will not affect the normal operation of flushing water intake. The contractor shall obtain consensus from all relevant parties, including WSD and Marine Department, on the design of the silt screen at each of the selected flushing water intake points before installation of the silt screen and commencement of the proposed marine works. The proposed water quality monitoring and audit shall be implemented by the contractor to ensure that the proposed works do not result in unacceptable impacts at the WSD flushing water intakes. As a mitigation measure to avoid the pollutant and refuse entrapment problems and to ensure that the impact monitoring results are representative, regular maintenance of the silt screens and refuse collection should be performed by the contractor at the silt screens at regular intervals on a daily basis. The Contractor should be responsible for keeping the water behind the silt screen free from floating rubbish and debris during the impact monitoring period. The contractor should be responsible for keeping the water behind the silt screen from floating rubbish and debris before the silt screens are removed.

4.7 Post-construction Monitoring

4.7.1 Upon completion of all marine-based construction activities, a post-project monitoring exercise on water quality shall be carried out for four weeks in the same manner as the impact monitoring as described in Section 4.6.

4.8 Field Log

4.8.1 Other relevant data should also be recorded, including monitoring location / position, time, water depth, sampling depth, pH, salinity, DO saturation, water temperature, tidal stages, weather conditions and any special phenomena or work underway nearby.

4.8.2 A sample data record sheet is shown in **Appendix B4** for reference.

4.9 Construction Site Audits

4.9.1 Implementation of regular site audits is to ensure that the recommended mitigation measures are to be properly undertaken during proposed marine construction works. It can also provide an effective control of any malpractices and therefore achieve continual improvement of environmental performance on site.

Site Inspection

4.9.2 Site inspections shall be carried out by the ET and shall be based on the mitigation measures for water pollution control recommended in the implementation schedule as attached in **Appendix A**. In the event that the recommended mitigation measures are not fully or properly implemented, deficiency shall be recorded and reported to the site management. Suitable actions are to be carried out to:

- Record the problems and investigate the causes;
- Issue action notes to the Contractor who is responsible for the works;
- Implement remedial and corrective actions immediately;
- Re-inspect the site conditions upon completion of the remedial and corrective actions; and
- Record the event and discuss with the Contractor for preventive actions.

Compliance Audits

4.9.3 Compliance audits are to be undertaken to ensure that a valid discharge license has been issued by EPD prior to the discharge of effluent from the Project site. If monitoring of the treated effluent quality from the Works Areas is required during the construction phase of the Project, the monitoring should be carried out in accordance with the WPCO license which is under the ambit of regional office (RO) of EPD. The audit results reflect whether the effluent quality is in compliance with the discharge license requirements. In case of non-compliance, suitable actions by the relevant parties should be undertaken to:

- Notify the site management on the non-compliance;
- Identify the sources of pollution;
- Check the implementation status of the recommended mitigation measures;
- Investigate the operating conditions of the on-site treatment systems;
- Implement corrective and remedial actions to improve the effluent quality;
- Increase monitoring frequency until the effluent quality is in compliance with the discharge licence requirements; and
- Record the non-compliance and propose preventive measures.

4.10 Event and Action Plan for Construction Water Quality

4.10.1 The water quality assessment criteria, namely Action and Limit levels are shown in **Table 4.4**. When exceedances of water quality assessment criteria are detected at any designated monitoring stations, carry out the actions in accordance with the Action Plan in **Table 4.6** is recommended.

4.10.2 The ET Leader should assess the potential impacts caused by dredging or filling works on the seawater intakes based on the monitoring data. The performance of the environmental management system (i.e. of the overall EM&A programme) should be reviewed by the ET Leader on a quarterly basis. The findings of this review should be included in the quarterly EM&A summary reports, together with any recommendations to improve the performance of the EM&A programme.

Table 4.4 Action and Limit Levels for Marine Water Quality at Seawater Intakes

Parameters	Action	Limit
WSD Salt Water Intake		
SS in mg L ⁻¹	95 percentile of baseline data or >9.5 mg/l	99 percentile of baseline data or >10 mg/l
Turbidity in NTU	95 percentile of baseline data or >9.5 NTU	99 percentile of baseline data or >10 NTU
DO in mg/L	5 percentile of baseline data or <2.1 mg/l	1 percentile of baseline data or <2 mg/l
Cooling Water Intake		
SS in mg L ⁻¹	95 percentile of baseline data	99 percentile of baseline data
Turbidity in NTU	95 percentile of baseline data	99 percentile of baseline data
DO in mg/L	5 percentile of baseline data	1 percentile of baseline data

Notes:

1. It is recommended to conduct the monitoring behind the silt screens and at the appropriate vertical levels of the abstraction points of these intakes
2. For turbidity and SS, non-compliance of the water quality limits occurs when monitoring result is higher than the limits.
3. For DO, non-compliance of the water quality limits occurs when monitoring result is lower than the limits.
4. All the figures given in the table are used for reference only and the EPD may amend the figures whenever it is considered as necessary.

4.10.3 If monitoring results indicate that the dredging or filling works have caused an adverse impact on water quality at the WSD saltwater intakes or cooling water intakes, it is recommended that the contractor should inform WSD and the owners of cooling water intakes. The contractor, the ET and the IEC should inform WSD immediately if an adverse impact on water quality has been caused or the monitoring results reach the action level at the WSD saltwater intakes. Additional mitigation measures should be recommended to rectify the non-compliance or the construction programme should be carefully reviewed to slow down the rate of dredging or filling. A turbidity meter should be installed at the intake of Wan Chai Salt Water Pumping Station so that WSD can check the turbidity any time and take remedial measures if the limits are exceeded.

4.10.4 Where necessary, EPD routine marine water quality monitoring data at the relevant station(s), dry and wet seasons inclusive, could be used to account for the variation of the data between dry season and wet season. The variation percentage between two seasons is then applied to the baseline monitoring data (Oct-Nov 2009) for dry season to derive the action and limit levels for impact monitoring in the wet season. To better represent the seasonal variation, it is suggested to establish Action and Limit levels for both dry and wet seasons for impact monitoring. The proposed Action and Limit Levels (Dry Seasons) and calculated Action and Limit Levels (Wet Seasons) for water quality monitoring are shown in **Table 4.5**. Details of establishing Action and Limit levels shall be referred to **Appendix D**.

Table 4.5 The Proposed Action and Limit Levels (Dry Seasons) and Calculated Action and Limit Levels (Wet Seasons) for water quality monitoring

Parameters	Dry Season		Wet Season	
	Action	Limit	Action	Limit
WSD Salt Water Intake				
SS in mg L ⁻¹	13.00	14.43	16.26	19.74
Turbidity in NTU	8.04	9.49	10.01	11.54
DO in mg/L	3.66	3.28	3.17	2.63
Cooling Water Intake				
SS in mg L ⁻¹	15.00	22.13	18.42	27.54
Turbidity in NTU	9.10	10.25	11.35	12.71
DO in mg/L	3.36	2.73	3.02	2.44

4.11 Mitigation of Adverse Environmental Impacts

- 4.11.1 Mitigation measures for water quality control have been recommended in the EIA Report. The Contractor should be responsible for the design and implementation of these measures.
- 4.11.2 Recommended mitigation measures to minimize the adverse impacts on water quality during the proposed dredging are listed in the implementation schedule given in **Appendix A**.

Table 4.6 Event and Action Plan for Marine Water Quality

EVENT	ACTION			
	ET	IEC	ER	CONTRACTOR
Action level being exceeded by one sampling day	Repeat in-situ measurement to confirm findings; Identify source(s) of impact; Inform IEC and Contractor; Check monitoring data, all plant, equipment and Contractor's working methods; Discuss mitigation measures with IEC and Contractor; (The above actions should be taken within 1 working day after the exceedance is identified) Repeat measurement on next day of exceedance.	Discuss with ET and Contractor on the mitigation measures; Review proposals on mitigation measures submitted by Contractor and advise the ER accordingly; Assess the effectiveness of the implemented mitigation measures. (The above actions should be taken within 1 working day after the exceedance is identified)	Discuss with IEC on the proposed mitigation measures; Make agreement on the mitigation measures to be implemented. (The above actions should be taken within 1 working day after the exceedance is identified)	Inform the ER and confirm notification of the non-compliance in writing; Rectify unacceptable practice; Check all plant and equipment; Consider changes of working methods; Discuss with ET and IEC and propose mitigation measures to IEC and ER; Implement the agreed mitigation measures. (The above actions should be taken within 1 working day after the exceedance is identified)
Action level being exceeded by more than one consecutive sampling days	Identify source(s) of impact; Inform IEC and Contractor; Check monitoring data, all plant, equipment and Contractor's working methods; Discuss mitigation measures with IEC and Contractor; Ensure mitigation measures are implemented; Prepare to increase the monitoring frequency to daily; (The above actions should be taken within 1 working day after the exceedance is identified) Repeat measurement on next working day of exceedance.	Discuss with ET and Contractor on the mitigation measures; Review proposals on mitigation measures submitted by Contractor and advise the ER accordingly; Assess the effectiveness of the implemented mitigation measures. (The above actions should be taken within 1 working day after the exceedance is identified)	Discuss with IEC on the proposed mitigation measures; Make agreement on the mitigation measures to be implemented; Assess the effectiveness of the implemented mitigation measures. (The above actions should be taken within 1 working day after the exceedance is identified)	Inform the Engineer and confirm notification of the non-compliance in writing; Rectify unacceptable practice; Check all plant and equipment; Consider changes of working methods; Discuss with ET and IEC and propose mitigation measures to IEC and ER within 3 working days; Implement the agreed mitigation measures. (The above actions should be taken within 1 working day after the exceedance is identified)

EVENT	ACTION			
	ET	IEC	ER	CONTRACTOR
Limit level being exceeded by one sampling day	<p>Repeat in-situ measurement to confirm findings; Identify source(s) of impact; Inform IEC, contractor and EPD; Check monitoring data, all plant, equipment and Contractor's working methods; Discuss mitigation measures with IEC, ER and Contractor; Ensure mitigation measures are implemented; Increase the monitoring frequency to daily until no exceedance of Limit level. (The above actions should be taken within 1 working day after the exceedance is identified)</p>	<p>Discuss with ET and Contractor on the mitigation measures; Review proposals on mitigation measures submitted by Contractor and advise the ER accordingly; Assess the effectiveness of the implemented mitigation measures. (The above actions should be taken within 1 working day after the exceedance is identified)</p>	<p>Discuss with IEC, ET and Contractor on the proposed mitigation measures; Request Contractor to critically review the working methods; Make agreement on the mitigation measures to be implemented; Assess the effectiveness of the implemented mitigation measures. (The above actions should be taken within 1 working day after the exceedance is identified)</p>	<p>Inform the Engineer and confirm notification of the non-compliance in writing; Rectify unacceptable practice; Check all plant and equipment; Consider changes of working methods; Discuss with ET , IEC and ER and propose mitigation measures to IEC and ER within 3 working days; Implement the agreed mitigation measures. (The above actions should be taken within 1 working day after the exceedance is identified)</p>
Limit level being exceeded by more than one consecutive sampling days	<p>Identify source(s) of impact; Inform IEC, contractor and EPD; Check monitoring data, all plant, equipment and Contractor's working methods; Discuss mitigation measures with IEC, ER and Contractor; Ensure mitigation measures are implemented; Increase the monitoring frequency to daily until no exceedance of Limit level for two consecutive days. (The above actions should be taken within 1 working day after the exceedance is identified)</p>	<p>Discuss with ET and Contractor on the mitigation measures; Review proposals on mitigation measures submitted by Contractor and advise the ER accordingly; Assess the effectiveness of the implemented mitigation measures. (The above actions should be taken within 1 working day after the exceedance is identified)</p>	<p>Discuss with IEC, ET and Contractor on the proposed mitigation measures; Request Contractor to critically review the working methods; Make agreement on the mitigation measures to be implemented; Assess the effectiveness of the implemented mitigation measures; Consider and instruct, if necessary, the Contractor to slow down or to stop all or part of the marine work until no exceedance of Limit level. (The above actions should be taken within 1 working day after the exceedance is identified)</p>	<p>Inform the ER and confirm notification of the non-compliance in writing; Rectify unacceptable practice; Check all plant and equipment; Consider changes of working methods; Discuss with ET , IEC and ER and propose mitigation measures to IEC and ER within 3 working days; Implement the agreed mitigation measures; As directed by the Engineer, to slow down or to stop all or part of the marine work or construction activities. (The above actions should be taken within 1 working day after the exceedance is identified)</p>

CONTENTS

5 WASTE MANAGEMENT 5-1
5.1 Introduction..... 5-1
5.2 Waste Control and Mitigation Measures 5-1

5 WASTE MANAGEMENT

5.1 Introduction

- 5.1.1 Waste management will be the contractor's responsibility to ensure that all wastes produced during the construction of the Project are handled, stored and disposed of in accordance with the recommended good waste management practices and EPD's regulations and requirements. The contractor will be required to ensure that loss of dredged material does not take place during transportation of the material in barges to the designated marine disposal ground.
- 5.1.2 Other waste materials generated during the construction activities, such as construction and demolition (C&D) materials, chemical wastes and general refuse from the workforce, are recommended to be audited at regular intervals (at least quarterly) to ensure that proper storage, transportation and disposal practices are being implemented. This monitoring of waste management practices will ensure that these solid and liquid wastes generated during construction are not disposed of into the surrounding marine waters. The Contractor will be responsible for the implementation of any mitigation measures to minimise waste or redress problems arising from the waste materials.

5.2 Waste Control and Mitigation Measures

- 5.2.1 Mitigation measures for waste management of the Projects are summarised below. The Implementation Schedule of the recommended mitigation measures is presented in **Appendix A**. With the appropriate handling, storage and removal of waste arising during the construction of the Project as defined below, the potential to cause adverse environmental impacts will be minimised. In order to ensure that the mitigation measures are properly implemented by the Contractor, regular site inspections by the ET shall be carried out at least once per week. Details of the audit requirements are set out in Section 9 of this EM&A Manual.

Dredged Marine Sediments

- 5.2.2 The basic requirements and procedures for dredged mud disposal are specified under the ETWB TCW No. 34/2002. The MFC is responsible for the provision and management of disposal capacity for dredged/excavated sediment, and DEP is responsible for the issue of permits for marine disposal under the provisions of the Dumping at Sea Ordinance (Cap. 466).
- 5.2.3 The dredged marine sediments would be loaded onto barges and transported to and disposed of at the designated disposal sites at South of Cheung Chau, East of Ninepin, East of Tung Lung Chau, South of Tsing Yi and East of Sha Chau to be allocated by the Marine Fill Committee depending on their level of contamination after consultation with the MFC and EPD. Based on the chemical screening results, the majority of the marine sediment to be dredged was classified as contaminated and would require Type 2 confined marine disposal. In accordance with the ETWB TCW No. 34/2002, the contaminated material must be dredged and transported with great care, and the mitigation measures recommended in the EIA Report should be strictly followed. Furthermore, the dredged contaminated sediment must be effectively isolated from the environment upon final disposal and the project proponent will consult the Marine Fill Committee about the disposal requirement. The final disposal site will be determined by the Marine Fill Committee and a dumping licence will be obtained from EPD prior to the commencement of the dredging works.

- 5.2.4 Based on the biological screening results, the Category H (>10xLCEL) sediment which failed the biological testing would require Type 3 special disposal. The volume of Category H sediment from the Causeway Bay typhoon shelter which would require special disposal arrangements is estimated to be approximately 0.05 Mm³. It was agreed with EPD during the WDII Comprehensive Feasibility Study (CFS) that special disposal arrangements, rather than pre-treatment, would be appropriate provided there would be negligible loss of sediment to the marine environment during the dumping operations.⁽¹⁾ A detailed review of possible special disposal arrangements for the contaminated sediment was carried out in the WDII CFS with the objective of keeping the loss of sediment to the surrounding marine environment to a negligible extent. The method pursued as having the least potential for loss of contaminants to the marine environment is by containment of the sediments in geosynthetic containers. A feasible containment method is proposed whereby the dredged sediments are sealed in geosynthetic containers and, at the disposal site, the containers would be dropped into the designated contaminated mud pit where they would be covered by further mud disposal and later by the mud pit capping, thereby meeting the requirements for fully confined mud disposal. The technology is readily available for the manufacture of the geosynthetic containers to the project-specific requirements. Similar disposal methods have been used for projects in Europe, the USA and Japan (for example, geosynthetic fabric containers have been used to contain contaminated dredged sediment at Marina Del Rey in California and Yokohama Port in Japan) and the issues of fill retention by the geosynthetic fabrics, possible rupture of the containers and sediment loss due to impact of the container on the seabed have been addressed.⁽²⁾ The recommended field trials were undertaken during the WDII Design and Construction (D&C) consultancy (Agreement No. CE54/2001 (CE)) using uncontaminated mud to demonstrate the feasibility of the proposed method.
- 5.2.5 The ACE Report⁽³⁾ [to be endorsed by ACE] on the field trials of geosynthetic containers concluded that disposal by sealing the dredged sediments in geosynthetic containers and dropping these containers into the contaminated mud pits at East Sha Chau has been shown to be a successful and viable disposal method. The use of a geosynthetic container system for special disposal was considered to be an effective system with negligible loss of contaminants to the marine environment during disposal. The container design and handling method were refined through the field trials for the determination of the optimal design and handling method.
- 5.2.6 It will be the responsibility of the Contractor to satisfy the appropriate authorities that the contamination levels of the marine sediment to be dredged have been analysed and recorded. According to the ETWB TCW No. 34/2002, this will involve the submission of a formal Sediment Quality Report to the DEP, at least 3 months prior to the dredging contract being tendered.

⁽¹⁾ Agreement No. CE 74/98. Wan Chai Development Phase II Comprehensive Feasibility Study. EIA Report. July 2001.

⁽²⁾ (i) Young, H. M. et al. "The migration of contaminants through geosynthetic fabric containers utilized in dredging operation". *Engineering Geology*, 53 (1999), 167-176;
(ii) Fleischer, P., Bowles, F. A. "Turbidity currents generated by seafloor impact of geotextile fabric containers". *Applied Ocean Research*, 21 (1999) 215-217;
(iii) Valent, P. J. et al. "Engineering concepts for the placement of wastes on the abyssal seafloor". *Journal of Marine Systems*, 14 (1998) 273-288.

⁽³⁾ Agreement No. CE 54/2001 (CE). Wan Chai Development Phase II – Design & Construction. Field Trials of Geosynthetic Containers – ACE Report.

5.2.7 During transportation and disposal of the dredged marine sediments requiring Type 1 and Type 2 disposal, the following measures should be taken to minimise potential impacts on water quality:

- Bottom opening of barges shall be fitted with tight fitting seals to prevent leakage of material.
- Monitoring of the barge loading shall be conducted to ensure that loss of material does not take place during transportation. Transport barges or vessels shall be equipped with automatic self-monitoring devices as specified by the DEP.
- Barges or hopper barges shall not be filled to a level that would cause the overflow of materials or sediment laden water during loading or transportation.

Good Site Practices

5.2.8 Adverse impacts related to waste management are not expected to arise, provided that good site practices are strictly followed. Recommendations for good site practices during the construction activities include:

- Nomination of an approved person, such as a site manager, to be responsible for good site practices, arrangements for collection and effective disposal to an appropriate facility, of all wastes generated at the site.
- Training of site personnel in proper waste management and chemical waste handling procedures.
- Provision of sufficient waste disposal points and regular collection for disposal.
- Appropriate measures to minimise windblown litter and dust during transportation of waste by either covering trucks or by transporting wastes in enclosed containers.
- Regular cleaning and maintenance programme for drainage systems, sumps and oil interceptors.
- A recording system for the amount of wastes generated, recycled and disposed of (including the disposal sites).

Waste Reduction Measures

5.2.9 Good management and control can prevent the generation of a significant amount of waste. Waste reduction is best achieved at the planning and design stage, as well as by ensuring the implementation of good site practices. Recommendations to achieve waste reduction include:

- Sort C&D waste from demolition of the existing waterfront structures to recover recyclable portions such as metals.
- Segregation and storage of different types of waste in different containers, skips or stockpiles to enhance reuse or recycling of materials and their proper disposal.
- Encourage collection of aluminium cans, PET bottles and paper by providing separate labelled bins to enable these wastes to be segregated from other general refuse generated by the work force.
- Any unused chemicals or those with remaining functional capacity shall be recycled.
- Use of reusable non-timber formwork, such as in casting the tunnel box sections, to reduce the amount of C&D material.
- Proper storage and site practices to minimise the potential for damage or contamination of construction materials.
- Plan and stock construction materials carefully to minimise amount of waste generated and avoid unnecessary generation of waste.

- 5.2.10 In addition to the above measures, specific mitigation measures are recommended below for the identified waste arisings to minimise environmental impacts during handling, transportation and disposal of these wastes.

General Refuse

- 5.2.11 General refuse should be stored in enclosed bins or compaction units separate from C&D material. A licensed waste collector should be employed by the contractor to remove general refuse from the site, separately from C&D material. Preferably an enclosed and covered area should be provided to reduce the occurrence of 'wind blown' light material.

Chemical Wastes

- 5.2.12 After use, chemical wastes (for example, cleaning fluids, solvents, lubrication oil and fuel) should be handled according to the *Code of Practice on the Packaging, Labelling and Storage of Chemical Wastes*. Spent chemicals should be collected by a licensed collector for disposal at the CWTF or other licensed facility, in accordance with the Waste Disposal (Chemical Waste) (General) Regulation.

Construction and Demolition Material

- 5.2.13 The C&D material should be sorted on-site into inert C&D material (that is, public fill) and C&D waste. Considering that a large quantity of C&D material will be generated from the demolition works and excavation for the tunnel construction and in order to minimise the impact resulting from collection and transportation of material for off-site disposal, it is recommended that the inert C&D material should be re-used on-site in the reclamation works as far as practicable. All the suitable (inert) material should be broken down to 250 mm in size for reuse as public fill and surcharge in the WDII reclamation. C&D waste, such as wood, glass, plastic, steel and other metals should be reused or recycled and, as a last resort, disposed of to landfill. It is recommended that a suitable area be designated to facilitate the sorting process and a temporary stockpiling area will be required for the separated materials. The quantities of C&D materials generated is estimated to be approximately 2.915Mm³ and around 1.17Mm³ will be reused on-site and the remaining surplus of around 1.745Mm³ will be disposed off-site.
- 5.2.14 In order to monitor the disposal of public fill and C&D waste at public fill reception facilities and landfills, respectively, and to control fly tipping, a trip-ticket system should be included as one of the contractual requirements and implemented by an Environmental Team undertaking the Environmental Monitoring and Audit work. An Independent Environmental Checker should be responsible for auditing the results of the system.
- 5.2.15 Bentonite slurries used in diaphragm wall and bore-pile construction should be reconditioned and reused wherever practicable. The disposal of residual used bentonite slurry should follow the good practice guidelines stated in ProPECC PN 1/94 "Construction Site Drainage" and listed as follows:
- If the disposal of a certain residual quantity cannot be avoided, the used slurry may be disposed of at the marine spoil grounds subject to obtaining a marine dumping licence from EPD on a case-by-case basis.
 - If the used bentonite slurry is intended to be disposed of through the public drainage system, it should be treated to the respective effluent standards applicable to foul sewers, storm drains or the receiving waters as set out in the *Technical Memorandum of Standards for Effluents Discharged into Drainage and Sewerage Systems, Inland and Coastal Waters*.
 - If the used bentonite slurry is intended to be disposed to public fill reception facilities, it will be mixed with dry soil on site before disposal.

CONTENTS

7 MARINE ECOLOGY 7-1

7.1 Introduction..... 7-1

7.2 Mitigation measures for corals 7-1

7.3 Monitoring requirement..... 7-2

LIST OF FIGURES

Figure 7.1 Spot-check Dive Sites and REA Transects-1

Figure 7.2 Spot-check Dive Sites and REA Transects-2

Figure 7.3 Proposed Coral Recipient Site at Junk Bay

7 MARINE ECOLOGY

7.1 Introduction

- 7.1.1 The marine ecological impact assessment conducted concluded that impacts from the proposed Project were mainly associated with the direct loss of marine habitats due to dredging and reclamation works in the Victoria Harbour. In terms of ecological importance, the assessment indicated that the affected habitats were generally of very low ecological value and no adverse ecological impacts on marine ecological resources are expected to occur.
- 7.1.2 Nevertheless, it is recommended to avoid direct loss or damage of any species of conservation interest within the proposed reclamation areas as far as possible. Translocation of all the existing coral colonies found at the coastlines within ex-PCWA Basin and along seawall at North Point is recommended in the marine ecological impact assessment.
- 7.1.3 Other indirect impacts on marine ecology arising from the Project are considered temporary and minimal in nature. With the implementation of appropriate mitigation measures (e.g. water quality and noise control measures, coral translocation and re-construction of new artificial seawalls), it was concluded that adverse impact on marine life and other species of conservation interest such as corals would not occur during the construction and operation of the Project. Nevertheless, post-translocation coral monitoring is proposed as an additional measure to verify the effectiveness of the coral translocation measure.

7.2 Mitigation measures for corals

- 7.2.1 The dive surveys conducted during the environmental impacts assessment stage in July 2007 or earlier revealed that coral within subtidal habitat that would be directly affected by the proposed reclamation works was low in species diversity (only two species, *Oulastrea crispata* and *Echinomuricea* sp.) and coverage (1 – 5%), with only small colonies and common species recorded. The subtidal habitat was therefore considered as low ecological value. Nevertheless, those 19 coral colonies identified in these previous dive surveys were attached to small movable boulders and are practically feasible for translocation. In addition, the recorded corals are not competitive and aggressive species which are not expected to have any negative pressure on the other existing corals in the coral translocation recipient site and are therefore considered suitable for translocation. Coral translocation exercise has been successfully carried out in other part of Hong Kong water in the past project (Black & Veatch, 2005, Proposed Extension of Public Golf Course at Kau Sai Chau Island, Sai Kung.) and post-translocation monitoring showed that no adverse impacts on the transplanted coral were resulted from the translocation exercise.
- 7.2.2 In this Project, the assessment recommended to translocate all these potentially affected coral colonies found at coastlines within ex-PCWA Basin (Site 13) and along seawall at North Point (Site 27) (**Figure 7.1 & 7.2**) to the nearby suitable habitats. To maximize the successfulness of this translocation exercise, the coral recipient sites should be as near as possible to the existing coral site and with similar healthy coral communities of the same species as well as similar hydrographic condition. Three possible recipient sites are identified in the vicinity of the assessment area (Victoria Harbour, Junk Bay and Clearwater Bay) and Junk Bay is considered as the most suitable option and be suggested as marine waters of the Victoria Harbour might be subjected to potential impact from future development including some marine works in the Central and Kai Tak areas while Clearwater Bay is considered too far away from the Project site when compared with Junk Bay.

- 7.2.3 A 10 m x 10 m coastal area at Junk Bay is proposed as a practical and feasible recipient site (**Figure 7.3**). Coral translocation to this proposed recipient site should not engage any permitting application under the Dumping at Sea Ordinance (Cap. 466) nor the Foreshore and Seabed (Reclamation) Ordinance (Cap. 127). In addition, this proposed recipient site is unleased and unallocated government land with no specific marine use and are therefore considered practically suitable for coral translocation. The proposed area (100 m²) of coral recipient site will provide sufficient space for proper placement of translocated coral colonies in the field based on rough estimate of about 20 rocks / boulders with attached coral colonies (occupying the largest area of less than 0.25 m² each) would be translocated to this recipient site. The translocation exercise should be conducted before the commencement of construction phase of the Project.
- 7.2.4 General steps for the whole coral translocation exercise are suggested below and should be followed as far as practicable:
- Locate a suitable recipient site for transplanted corals before commencement of coral translocation works;
 - Collect baseline information (e.g. total number of coral colonies to be translocated, health status, attached boulder size, etc.) of transplanted coral colonies in pre-translocation survey before commencement of coral translocation works;
 - Tag the transplanted coral colonies one by one in the pre-translocation survey;
 - Record the size, depth and orientation of each tagged coral colonies in the pre-translocation survey;
 - Move boulders with translocated coral colonies from sea bottom to ship/boat with lifting bag;
 - Submerge translocated coral colonies in large plastic bucket filled with seawater with aeration onboard;
 - Transport coral colonies to recipient site as quick as possible;
 - Place the transplanted coral colonies in the recipient site in similar depth and orientation as the existing coral site;
 - Record information (e.g. health status, translocated location of tagged coral, etc) of transplanted coral colonies upon the completion of translocation works; and
 - Carry out post-translocation monitoring on transplanted coral colonies every three months for a year after completion of coral translocation works.
- 7.2.5 A detailed transplantation plan (including identification of recipient site, translocation methodology, monitoring of transplanted corals, etc.) should be drafted during the detailed design stage of the Project. The translocation plan should be proposed by the ET in agreement with the IEC and should be approved by AFCD prior to the commencement of coral translocation exercise and monitoring programme. Both coral translocation and monitoring exercise should be carried by qualified marine specialist who has suitable coral knowledge and sound experience in identifying corals in field situation, and to be approved by AFCD as well.

7.3 Monitoring requirement

Baseline Survey

- 7.3.1 Prior to the commencement of coral translocation, baseline survey of corals should be conducted at the ex-PWCA Basin (Site 13) and along seawall at North Point (Site 27) (**Figure 7.1 & 7.2**). All the potentially affected coral colonies should be tagged. For each tagged coral, specific detailed information should be collected including location, size, depth, attached rock/boulder size and general condition of their immediate surroundings. Tagged coral colonies should also be identified to the highest taxonomic resolution as far as practicable. The condition of each tagged coral colony should also be recorded by taking a photograph from an angle that best represents the entire colony.

- 7.3.2 Information on health condition of the tagged corals should be recorded. For gorgonian coral, the percentage of branches affected by partial mortality and secretion of mucus should be recorded. For hard corals, health condition should include information on surface area with partial mortality and blanched / bleached area. Two categories of bleached area should be recorded:
- Blanched (i.e. paled)
 - Bleached (i.e. bleached white)
- 7.3.3 Blanched coral tissue would appear pale due a loss of zooxanthallae or photosynthetic pigments. In contrast, bleached areas would appear white due to the white colouration of the skeleton visible through the transparent coral tissue. This bleaching would occur due to total loss of zooxanthellae. The coral tissue would still be present. It is possible that the lower portions of the coral tissue remain unbleached and would therefore help in differentiating bleached areas as opposed to partial mortality areas where the coral tissue would be absent.
- 7.3.4 For each tagged hard coral colony, sediment cover should be recorded including percentage cover, colouration, texture and approximate thickness of sediment on the colony itself and on adjacent hard substrate. Any contiguous patches of sediment cover >10% should be counted. To aid percentage cover estimates, a 50 cm x 50 cm quadrat equipped with 10cm spaced string grid should be used.

Coral monitoring after transplantation

- 7.3.5 After translocation, the transplanted coral colonies should be regularly checked by qualified marine ecologist(s) to be approved by AFCD quarterly for one year after transplantation. Detailed monitoring proposal should be drafted during the detailed design phase of the Project and be approved by AFCD prior to the commencement of coral translocation.
- 7.3.6 Dive surveys for post-translocation monitoring should collect the same information for tagged corals as the baseline survey. Information gathered during each post-translocation monitoring surveys should include observations on the presence, survival, and health conditions of the transplanted coral colonies. It should also include condition of the surrounding environment as well as weather, sea and tidal conditions. Each tagged coral should be photographed as far as possible maintaining the same aspect and orientation as photographs taken for the baseline survey.
- 7.3.7 All tags should be removed / retrieved after the monitoring programme is completed.

Reporting

- 7.3.8 A baseline survey report should be submitted to AFCD prior to the commencement of coral translocation exercise.
- 7.3.9 Post-translocation monitoring report should be submitted to AFCD within 2 weeks after the completion of coral translocation and each quarterly coral monitoring survey. The results of the post-translocation monitoring surveys should be reviewed with reference to the baseline survey results and findings of the condition of surrounding environment.

CONTENTS

8	LANDSCAPE AND VISUAL	8-1
8.1	Introduction.....	8-1
8.2	Monitoring Details.....	8-1
8.3	Baseline Monitoring	8-2
8.4	Event/Action Plan for Landscape and Visual Works	8-2
8.5	Mitigation Measures.....	8-4

LIST OF TABLES

Table 8.1	Monitoring Programme
Table 8.2	Construction & Establishment Periods
Table 8.3	Long Term Management

LIST OF FIGURES

Figure 8.1a	Baseline Landscape Resources During Construction
Figure 8.1b	Baseline Landscape Resources During Operation
Figure 8.2a	Baseline Landscape Character Areas During Construction
Figure 8.2b	Baseline Landscape Character Areas During Operation
Figure 8.3a	Key VSRs and Primary Zone of Visual Influence During Construction
Figure 8.3b	Key VSRs and Primary Zone of Visual Influence Operation
Figure 8.3c	Key VSRs and Secondary Zone of Visual Influence

8 LANDSCAPE AND VISUAL

8.1 Introduction

8.1.1 The EIA has recommended landscape and visual mitigation measures to be undertaken during both the construction and operational phases of the project. This section outlines the monitoring and audit of these measures.

8.1.2 The key landscape resources, landscape character areas and visual sensitive receivers are shown in **Figures 8.1a, 8.1b, 8.2a, 8.2b, 8.3a, 8.3b, 8.3c.**

8.2 Monitoring Details

8.2.1 The design, implementation and maintenance of landscape mitigation measures should be checked to ensure that they are fully realised and that potential conflicts between the proposed landscape measures and any other project works and operational requirements are resolved at the earliest possible date and without compromise to the intention of the mitigation measures.

Table 8.1 Monitoring Programme

Stage	Monitoring Task	Monitoring Report	Form of Approval	Frequency
Design	Monitoring of design works against the recommendations of the landscape and visual impact assessments within the EIA should be undertaken during detailed design and tender stages, to ensure that they fulfil the intentions of the mitigation measures. Any changes to the design, including design changes on site should also be checked.	Report by ER confirming that the design conforms to requirements of EP	Approved by Client	At Completion of Design Stage
Construction	Monitoring of the contractor's operations during the construction period.	Report on Contractor's compliance, by ET	Counter-signature of report by IEC	Weekly
Establishment Works	Monitoring of the planting works during the 24-month Establishment period after completion of the construction works.	Report on Contractor's compliance, by ET	Counter-signature of report by IEC	3 months
Long Term Operation (5 years)	Monitoring of the long-term management of the planting works in the period up to 5 years after completion of the construction works.	Report on compliance by ET or Maintenance Agency	Counter-signature of report by Management Agency	12 months

Design

- 8.2.2 The mitigation measures proposed within the EIA to mitigate the landscape and visual impacts of the scheme should be embodied into the detailed engineering design and landscape design drawings and contract documents. Designs should be checked to ensure that the measures are fully incorporated and that potential conflicts with civil engineering, geo-technical, structural, lighting, signage, drainage, underground utility and operational requirements are resolved prior to construction.
- 8.2.3 The Client should prepare a detailed 5-Year Management Programme for the long-term management and maintenance of the planting works following the Establishment periods. The Programme should include evaluation and objectives for management, details of the operations to be undertaken to achieve these objectives, and outline of work programmes.

Construction & Establishment Period

- 8.2.4 The implementation of landscape construction works and subsequent maintenance operations during the 12-month establishment period must be supervised by fully qualified Landscape Resident Site Staff (Registered Landscape Architect or Professional Member of the Hong Kong Institute of Landscape Architects).
- 8.2.5 Measures to mitigate landscape and visual impacts during construction should be checked to ensure compliance with the intended aims of the measures.
- 8.2.6 The progress of the engineering works shall be regularly reviewed on site to identify the earliest practical opportunities for the landscape works to be undertaken.

Long Term Management

- 8.2.7 The success or otherwise of all planting works intended to mitigate the visual and landscape impact of the roads, the noise barriers/screening/semi-enclosures and street lighting shall be monitored during the first ten years of the operational phase of the project. Any areas of vegetation which have failed to establish, should be corrected by the appropriate maintenance authorities at the earliest opportunity. Monitoring should include the long-term maintenance of the planting works under the detailed 5-Year Management Programme.

8.3 Baseline Monitoring

- 8.3.1 A photographic record of the site and a report recording the changes to each landscape resource, landscape character area and view condition of each visually sensitive receiver at the time of the contractor's possession of the site shall be prepared by the Contractor and approved by the ER. The approved photographic record and the report recording the changes shall be submitted to the Project proponent, ET, IEC and EPD for record.

8.4 Event/Action Plan for Landscape and Visual Works

- 8.4.1 Should non-compliance of the landscape and visual impacts occur, actions in accordance with the action plan stated in **Table 8.2 and 8.3** should be carried out.

Table 8.2 Construction & Establishment Periods

EVENT ACTION LEVEL	ACTION			
	ET	IEC	ER	CONTRACTOR
Design Check	<ul style="list-style-type: none"> Check final design conforms to the requirements of EP and prepare report. 	<ul style="list-style-type: none"> Check report. Recommend remedial design if necessary 	<ul style="list-style-type: none"> Undertake remedial design if necessary 	
Non-conformity on one occasion	<ul style="list-style-type: none"> Identify Source Inform IEC and ER Discuss remedial actions with IEC, ER and Contractor Monitor remedial actions until rectification has been completed 	<ul style="list-style-type: none"> Check report Check Contractor's working method Discuss with ET and Contractor on possible remedial measures Advise ER on effectiveness of proposed remedial measures. Check implementation of remedial measures. 	<ul style="list-style-type: none"> Notify Contractor Ensure remedial measures are properly implemented 	<ul style="list-style-type: none"> Amend working methods Rectify damage and undertake any necessary replacement
Repeated Non-conformity	<ul style="list-style-type: none"> Identify Source Inform IEC and ER Increase monitoring frequency Discuss remedial actions with IEC, ER and Contractor Monitor remedial actions until rectification has been completed If non-conformity stops, cease additional monitoring 	<ul style="list-style-type: none"> Check monitoring report Check Contractor's working method Discuss with ET and Contractor on possible remedial measures Advise ER on effectiveness of proposed remedial measures Supervise implementation of remedial measures. 	<ul style="list-style-type: none"> Notify Contractor Ensure remedial measures are properly implemented 	<ul style="list-style-type: none"> Amend working methods Rectify damage and undertake any necessary replacement

Table 8.3 Long Term Management

EVENT ACTION LEVEL	ACTION			
	MAINTENANCE AGENCY	MANAGEMENT AGENCY		
Non-conformity	<ul style="list-style-type: none"> Identify Source Discuss remedial actions with Management Agency Monitor remedial actions until rectification has been completed 	<ul style="list-style-type: none"> Check report Discuss with Maintenance Agency possible remedial measures Supervise implementation of remedial measures. 		

8.5 Mitigation Measures

8.5.1 The landscape and visual impact assessment of the EIA recommends a series on mitigation measures, as noted below:

Landscape and Visual Mitigation Measures during Construction Phase

For the Whole Project

- Topsoil, where identified, should be stripped and stored for re-use in the construction of the soft landscape works, where practical (CM1);
- Existing trees to be retained on site should be carefully protected during construction (CM2);
- Trees unavoidably affected by the works should be transplanted where practical (CM3);
- Compensatory tree planting should be provided to compensate for felled trees (CM4);
- Control of night-time lighting (CM5);
- Erection of decorative screen hoarding compatible with the surrounding setting (CM6).

For DP3 - Reclamation

- Control night-time lighting (CM5);
- Erection of decorative hoardings (CM6).

For DP5 – Wan Chai East Sewage Outfall (refer to EIA-058/2001, Table 10.13)

- Minimisation of works areas (CM2);
- Erection of decorative hoardings (CM3);
- Control night-time lighting (CM4);
- Minimisation of disruption to public by effective programming of the works (CM5).

For DP6 – Cross-Harbour Water Mains from Wan Chai to Tsim Sha Tsui (refer to EIA-058/2001, Table 10.13)

- Minimisation of works areas (CM2);
- Erection of decorative hoardings (CM3);
- Control night-time lighting (CM4);
- Minimisation of disruption to public by effective programming of the works (CM5).

Landscape and Visual Mitigation Measures during Operation Phase

8.5.2 The landscape and visual mitigation measures in the Operation Phase would be achieved principally through the realisation of a Master Landscape Plan encompassing the following principal objectives:

- the establishment of a network of open spaces providing for a range of functions including pedestrian circulation and as a venue for community events;
- the creation of major landscape spaces forming pedestrian arteries linking the waterfront with existing open spaces, proposed and existing adjacent developments and other areas of the city;
- the establishment of an integrated, pedestrian oriented streetscape which will enhance pedestrian movement, integrate the proposed and existing developments within an overall landscape framework and generally improve the quality of the public environment;
- the provision of green buffer areas to mitigate negative environmental conditions associated with transport corridors, especially for the proposed IECL;
- the development of an integrated, fully co-ordinated design, incorporating all foreseeable functional requirements such as utilities, drainage reserves, and pumping stations;

- the creation of a high quality Waterfront Park which will reflect and integrate with that proposed for the Central District Reclamation development;
- the provision of open space linkage between the Central Reclamation and HKCEC in the west, the RHKYC, Victoria Park and stretching to North Point to the east.

For the Whole Project

- Aesthetic design of buildings and road-related structures, including viaducts, vent buildings, subways, footbridges and noise barriers and enclosure (OM1);
- Shrub and Climbing Plants to soften proposed structures (OM2);
- Buffer Tree and Shrub Planting to screen proposed roads and associated structures (OM3);
- Aesthetic design of proposed waterfront promenade (OM4);
- Aesthetic streetscape design (OM5);
- Aesthetic design of roadside amenity areas (OM6).

For DP3 - Reclamation

- Aesthetic design of proposed waterfront promenade (OM4).

CONTENTS

9 SITE ENVIRONMENTAL AUDIT..... 9-1

9.1 Site Inspection..... 9-1

9.2 Compliance with Legal and Contractual Requirements..... 9-2

9.3 Environmental Complaints..... 9-2

9 SITE ENVIRONMENTAL AUDIT

9.1 Site Inspection

- 9.1.1 Site inspection provides a direct means to initiate and enforce specified environmental protection and pollution control measures. These shall be undertaken routinely to inspect construction activities in order to ensure that appropriate environmental protection and pollution control mitigation measures are properly implemented. The site inspection is one of the most effective tools to enforce the environmental protection requirements at the works area.
- 9.1.2 The ET Leader shall be responsible for formulating the environmental site inspection, the deficiency and action reporting system, and for carrying out the site inspection works. Within 21 days of the construction contract commencement, he shall submit a proposal for site inspection and deficiency and action reporting procedures to the Contractor for agreement, and to the ER for approval. The ET's proposal for rectification would be made known to the IEC.
- 9.1.3 Regular site inspections shall be carried out at least once per week. The areas of inspection shall not be limited to the environmental situation, pollution control and mitigation measures within the site; it should also review the environmental situation outside the works area which is likely to be affected, directly or indirectly, by the site activities. The ET Leader shall make reference to the following information in conducting the inspection:
- (i) EIA recommendations on environmental protection and pollution control mitigation measures;
 - (ii) works progress and programme;
 - (iii) individual works methodology proposals (which shall include proposal on associated pollution control measures);
 - (iv) contract specifications on environmental protection;
 - (v) relevant environmental protection and pollution control laws; and
 - (vi) previous site inspection results.
- 9.1.4 The Contractor shall keep the ET Leader updated with all relevant information on the construction contract necessary for him to carry out the site inspections. Inspection results and associated recommendations for improvements to the environmental protection and pollution control works shall be submitted to the IEC and the Contractor within 24 hours. The Contractor shall follow the procedures and time-frame as stipulated in the environmental site inspection, and the deficiency and action reporting system formulated by the ET Leader, to report on any remedial measures subsequent to the site inspections.
- 9.1.5 Ad hoc site inspections shall also be carried out if significant environmental problems are identified. Inspections may also be required subsequent to receipt of an environmental complaint, or as part of the investigation work, as specified in the Action Plan for environmental monitoring and audit.

9.2 Compliance with Legal and Contractual Requirements

- 9.2.1 There are contractual environmental protection and pollution control requirements as well as environmental protection and pollution control laws in Hong Kong with which construction activities must comply.
- 9.2.2 In order that the works are in compliance with the contractual requirements, all works method statements submitted by the Contractor to the ER for approval shall be sent to the ET Leader for vetting to see whether sufficient environmental protection and pollution control measures have been included. The implementation schedule of mitigation measures is summarised in **Appendix A**.
- 9.2.3 The ET Leader shall also review the progress and programme of the works to check that relevant environmental laws have not been violated, and that any foreseeable potential for violating laws can be prevented.
- 9.2.4 The Contractor shall regularly copy relevant documents to the ET Leader so that works checking can be carried out. The document shall at least include the updated Works Progress Reports, updated Works Programme, any application letters for different licence / permits under the environmental protection laws, and copies of all valid licences / permits. The site diary shall also be available for the ET Leader's inspection upon his request.
- 9.2.5 After reviewing the document, the ET Leader shall advise the IEC and Contractor of any non-compliance with contractual and legislative requirements on environmental protection and pollution control for them to take follow-up actions. If the ET Leader's review concludes that the current status on licence / permit application and any environmental protection and pollution control preparation works may result in potential violation of environmental protection and pollution control requirements, he shall also advise the Contractor and the ER accordingly.
- 9.2.6 Upon receipt of the advice, the Contractor shall undertake immediate action to correct the situation. The ER shall follow up to ensure that appropriate action has been taken in order to satisfy contractual and legal requirements.

9.3 Environmental Complaints

- 9.3.1 Complaints shall be referred to the ET Leader for action. The ET Leader shall undertake the following procedures upon receipt of any complaint:
- (i) log complaint and date of receipt onto the complaint database and inform the IEC immediately;
 - (ii) investigate the complaint to determine its validity, and assess whether the source of the problem is due to works activities;
 - (iii) identify mitigation measures in consultation with the IEC if a complaint is valid and due to works;
 - (iv) advise the Contractor if mitigation measures are required;
 - (v) review the Contractor's response to identified mitigation measures, and the updated situation;

-
- (vi) if the complaint is transferred from the EPD, submit interim report to the EPD on status of the complaint investigation and follow-up action within the time frame assigned by the EPD;
 - (vii) undertake additional monitoring and audit to verify the situation if necessary, and review that circumstances leading to the complaint do not recur;
 - (viii) report investigation results and subsequent actions to complainant (if the source of complaint is EPD, the results should be reported within the timeframe assigned by the EPD); and
 - (ix) record the complaint, investigation, the subsequent actions and the results in the monthly EM&A reports.

CONTENTS

10 REPORTING 10-1

- 10.1 General 10-1
- 10.2 Baseline Monitoring Report 10-1
- 10.3 Monthly EM&A Reports..... 10-2
- 10.4 Quarterly EM&A Summary Reports 10-7
- 10.5 Final EM&A Review Reports 10-8
- 10.6 Reporting for Post-construction / Post-Translocation Monitoring of Coral 10-10
- 10.7 Operation Phase EM&A Reporting 10-10
- 10.8 Data Keeping 10-10
- 10.9 Interim Notifications of Environmental Quality Limit Exceedances 10-10

10 REPORTING

10.1 General

- 10.1.1 Reports can be provided in an electronic medium upon agreeing the format with the ER and EPD. This would enable a transition from a paper / historic and reactive approach to an electronic / real time proactive approach. All the monitoring data (baseline and impact) shall also be submitted on diskettes. The formats for air quality, noise and water quality monitoring data to be submitted on diskette are shown in **Appendix B**.
- 10.1.2 Types of reports that the ET Leader shall prepare and submit include baseline monitoring report, monthly EM&A report, quarterly EM&A summary report and final EM&A review report. In accordance with Annex 21 of the EIAO-TM, a copy of the monthly, quarterly summary and final review EM&A reports shall be made available to the Director of Environmental Protection.

10.2 Baseline Monitoring Report

- 10.2.1 The ET Leader shall prepare and submit a Baseline Environmental Monitoring Report within 10 working days of completion of the baseline monitoring. Copies of the Baseline Environmental Monitoring Report shall be submitted to the Contractor, the IEC, the ER and the EPD. The ET Leader shall liaise with the relevant parties on the exact number of copies they require. The report format and baseline monitoring data format shall be agreed with the EPD prior to submission.
- 10.2.2 The baseline monitoring report shall include at least the following:
- (i) up to half a page executive summary;
 - (ii) brief project background information;
 - (iii) drawings showing locations of the baseline monitoring stations;
 - (iv) monitoring results (in both hard and diskette copies) together with the following information:
 - monitoring methodology;
 - name of laboratory and types of equipment used and calibration details;
 - parameters monitored;
 - monitoring locations;
 - monitoring date, time, frequency and duration; and
 - quality assurance (QA) / quality control (QC) results and detection limits;

- (v) details of influencing factors, including:
 - major activities, if any, being carried out on the site during the period;
 - weather conditions during the period; and
 - other factors which might affect results;
- (vi) determination of the Action and Limit Levels for each monitoring parameter and statistical analysis of the baseline data, the analysis shall conclude if there is any significant difference between control and impact stations for the parameters monitored;
- (vii) revisions for inclusion in the EM&A Manual; and
- (viii) comments, recommendations and conclusions.

10.3 Monthly EM&A Reports

- 10.3.1 The results and findings of all EM&A work required in the Manual shall be recorded in the monthly EM&A reports prepared by the ET Leader. The EM&A report shall be prepared and submitted within 10 working days of the end of each reporting month, with the first report due the month after construction commences. Each monthly EM&A report shall be submitted to the following parties: the Contractor, the IEC, the ER and the EPD. Before submission of the first EM&A report, the ET Leader shall liaise with the parties on the required number of copies and format of the monthly reports in both hard copy and electronic medium.
- 10.3.2 The ET leader shall review the number and location of monitoring stations and parameters every six months, or on as needed basis, in order to cater for any changes in the surrounding environment and the nature of works in progress.

First Monthly EM&A Report

- 10.3.3 The first monthly EM&A report shall include at least the following :

- (i) executive summary (1-2 pages):
 - breaches of Action and Limit levels;
 - complaint log;
 - notifications of any summons and successful prosecutions;
 - reporting changes; and
 - future key issues.

-
- (ii) basic project information:
- project organisation including key personnel contact names and telephone numbers;
 - programme;
 - management structure, and
 - works undertaken during the month;
- (iii) environmental status:
- Advice on the status of statutory environmental compliance, the status of compliance with environmental permit (EP) conditions under the EIA Ordinance, submission status under the EP and implementation status of mitigation measures.
 - works undertaken during the month with illustrations (such as location of works, daily excavation rate, etc); and
 - drawings showing the project area, any environmental sensitive receivers and the locations of the monitoring and control stations (with co-ordinates of the monitoring locations);
- (iv) a brief summary of EM&A requirements including:
- all monitoring parameters;
 - environmental quality performance limits (Action and Limit levels);
 - Event-Action Plans;
 - environmental mitigation measures, as recommended in the project EIA study final report; and
 - environmental requirements in contract documents;
- (v) implementation status:
- advice on the implementation status of environmental protection and pollution control / mitigation measures, as recommended in the project EIA;
- (vi) monitoring results (in both hard and diskette copies) together with the following information:
- monitoring methodology;
 - name of laboratory and types of equipment used and calibration details;
 - parameters monitored;
 - monitoring locations;
 - monitoring date, time, frequency, and duration;
 - weather conditions during the period;
-

Table 4.5 The Proposed Action and Limit Levels (Dry Seasons) and Calculated Action and Limit Levels (Wet Seasons) for water quality monitoring

Parameters	Dry Season		Wet Season	
	Action	Limit	Action	Limit
WSD Salt Water Intake				
SS in mg L ⁻¹	13.00	14.43	16.26	19.74
Turbidity in NTU	8.04	9.49	10.01	11.54
DO in mg/L	3.66	3.28	3.17	2.63
Cooling Water Intake				
SS in mg L ⁻¹	15.00	22.13	18.42	27.54
Turbidity in NTU	9.10	10.25	11.35	12.71
DO in mg/L	3.36	2.73	3.02	2.44

4.11 Mitigation of Adverse Environmental Impacts

- 4.11.1 Mitigation measures for water quality control have been recommended in the EIA Report. The Contractor should be responsible for the design and implementation of these measures.
- 4.11.2 Recommended mitigation measures to minimize the adverse impacts on water quality during the proposed dredging are listed in the implementation schedule given in **Appendix A**.

Subsequent EM&A Reports

10.3.4 Subsequent monthly EM&A reports shall include the following:

- (i) executive summary (1 - 2 pages):
 - breaches of Action and Limit levels;
 - complaints log;
 - notifications of any summons and successful prosecutions;
 - reporting changes; and
 - future key issues.
- (ii) basic project information:
 - project organisation including key personnel contact names and telephone numbers;
 - programme;
 - management structure; and
 - work undertaken during the month;
- (iii) environmental status:
 - works undertaken during the month with illustrations (such as location of works, daily excavation rate, etc.); and
 - drawing showing the project area, any environmental sensitive receivers and the locations of the monitoring and control stations.
 - Advice on the status of statutory environmental compliance, the status of compliance with environmental permit (EP) conditions under the EIA Ordinance, submission status under the EP and implementation status of mitigation measures.
- (iv) implementation status:
 - advice on the implementation status of environmental protection and pollution control / mitigation measures, as recommended in the project EIA;
- (v) monitoring results (in both hard and diskette copies) together with the following information:
 - monitoring methodology;
 - name of laboratory and types of equipment used and calibration details;
 - parameters monitored;
 - monitoring locations;
 - monitoring date, time, frequency, and duration;

- weather conditions during the period;
 - graphical plots of the monitored parameters in the month annotated against:
 - (i) major activities being carried out on site during the period
 - (ii) weather conditions that may affect the results
 - (iii) any other factors which might affect the monitoring results
 - any other factors which might affect the monitoring results; and
 - QA / QC results and detection limits.
- (vi) report on non-compliance, complaints, and notifications of summons and successful prosecutions:
- record of all non-compliance (exceedances) of the environmental quality performance limits (Action and Limit levels);
 - record of all complaints received (written or verbal) for each media, including locations and nature of complaints investigation, liaison and consultation undertaken, actions and follow-up procedures taken, results and summary;
 - record of all notification of summons and successful prosecutions for breaches of current environmental protection / pollution control legislation, including locations and nature of the breaches, investigation, follow-up actions taken, results and summary;
 - review of the reasons for and the implications of non-compliance, complaints, summons and prosecutions including review of pollution sources and working procedures; and
 - description of the actions taken in the event of non-compliance and deficiency reporting and any follow-up procedures related to earlier non-compliance.
- (vii) others
- compare and contrast the EM&A data in the month with the EIA predictions and annotate with explanation for any discrepancies;
 - an account of the future key issues as reviewed from the works programme and work method statements;
 - advice on the solid and liquid waste management status; and
 - comments (for examples, effectiveness and efficiency of the mitigation measures), recommendations (for example, any improvement in the EM&A programme) and conclusions.

- (viii) appendix
- Action and Limit levels;
 - graphical plots of trends of monitored parameters at key stations over the past four reporting periods for representative monitoring stations annotated against the following:
 - a) major activities being carried out on site during the period;
 - b) weather conditions during the period; and
 - c) any other factors that might affect the monitoring results.
 - monitoring schedule for the present and next reporting period;
 - cumulative statistics on complaints, notifications of summons and successful prosecutions; and
 - outstanding issues and deficiencies.

10.4 Quarterly EM&A Summary Reports

10.4.1 A quarterly EM&A summary report of around 5 pages shall be produced and shall contain at least the following information:

- (i) executive summary (1 - 2 pages);
- (ii) basic project information including a synopsis of the project organisation, programme, contacts of key management, and a synopsis of works undertaken during the quarter;
- (iii) a brief summary of EM&A requirements including:
 - monitoring parameters;
 - environmental quality performance limits (Action and Limit levels); and
 - environmental mitigation measures, as recommended in the project EIA Final Report;
- (iv) advice on the implementation status of environmental protection and pollution control / mitigation measures, as recommended in the project EIA Final Report, summarised in the updated implementation schedule;
- (v) drawings showing the project area, any environmental sensitive receivers and the locations of the monitoring and control stations;

- (vi) graphical plots of any trends in monitored parameters over the past four months (the last month of the previous quarter and the present quarter) for representative monitoring stations annotated against:
 - the major activities being carried out on site during the period;
 - weather conditions during the period; and
 - any other factors which might affect the monitoring results;
- (vii) advice on the solid and liquid waste management status;
- (viii) a summary of non-compliance (exceedances) of the environmental quality performance limits (Action and Limit levels);
- (ix) a brief review of the reasons for and the implications of any non-compliance, including a review of pollution sources and working procedures;
- (x) a summary description of actions taken in the event of non-compliance and any follow-up procedures related to any earlier non-compliance;
- (xi) a summarised record of all complaints received (written or verbal) for each media, liaison and consultation undertaken, actions and follow-up procedures taken;
- (xii) comments (for examples, a review of the effectiveness and efficiency of the mitigation measures and the performance of the environmental management system, that is, of the overall EM&A programme); recommendations (for example, any improvement in the EM&A programme) and conclusions for the quarter; and
- (xiii) proponents' contacts and any hotline telephone number for the public to make enquiries.

10.5 Final EM&A Review Reports

- 10.5.1 The EM&A program shall be terminated upon completion of those construction activities that have the potential to result in a significant environmental impact.
- 10.5.2 Prior to the proposed termination, it may be advisable to consult relevant local communities. The proposed termination should only be implemented after the proposal has been endorsed by the IEC, the Engineer and the Project Proponent followed by final approval from the Director of Environmental Protection.
- 10.5.3 The ET Leader shall prepare and submit a final EM&A report within 14 working days after the completion of those construction activities that have the potential to result in a significant environmental impact. The final EM&A report should contain at least the following information:
- (i) executive summary (1 - 2 pages);
 - (ii) drawings showing the project area, any environmental sensitive receivers and the locations of the monitoring and control stations;
 - (iii) basic project information including a synopsis of the project organisation, contacts of key management, and a synopsis of work undertaken during the course of the project or past twelve months;
 - (iv) a brief summary of EM&A requirements including:

- environmental mitigation measures, as recommended in the project EIA Report;
 - environmental impact hypotheses tested;
 - environmental quality performance limits (Action and Limit levels);
 - all monitoring parameters;
 - Event-Action Plans;
- (v) a summary of the implementation status of environmental protection and pollution control / mitigation measures, as recommended in the project EIA Report, summarised in the updated implementation schedule;
- (vi) graphical plots and the statistical analysis of the trends of monitored parameters over the course of the project, including the post-project monitoring for all monitoring stations annotated against:
- the major activities being carried out on site during the period;
 - weather conditions during the period; and
 - any other factors which might affect the monitoring results;
- (vii) a summary of non-compliance (exceedances) of the environmental quality performance limits (Action and Limit levels);
- (viii) a review of the reasons for and the implications of non-compliance including review of pollution sources and working procedures as appropriate;
- (ix) a description of the actions taken in the event of non-compliance;
- (x) a summary record of all complaints received (written or verbal) for each media, liaison and consultation undertaken, actions and follow-up procedures taken;
- (xi) a summary record of notifications of summons and successful prosecutions for breaches of the current environmental protection / pollution control legislation, locations and nature of the breaches, investigation follow-up actions taken and results;
- (xii) a review of the validity of EIA predictions and identification of shortcomings in EIA recommendations; and
- (xiii) comments (for examples, a review of the effectiveness and efficiency of the mitigation measures and of the performance of the environmental management system, that is, of the overall EM&A programme);
- (xiv) recommendations and conclusions (for example, a review of success of the overall EM&A programme to cost-effectively identify deterioration and to initiate prompt effective mitigatory action when necessary).

10.6 Reporting for Post-construction / Post-Translocation Monitoring of Coral

- 10.6.1 Prior to the commencement of construction phase of the Project and the coral translocation exercise, the ET shall prepare and submit a detailed transplantation plan and monitoring proposal of coral. The translocation plan and monitoring proposal shall be approved by AFCD. A baseline survey report shall be prepared and submitted to AFCD prior to the commencement of coral translocation exercise. Post-translocation monitoring report shall be prepared and submitted to AFCD within 2 weeks after the completion of coral translocation and each quarterly coral monitoring survey. The results of the post-translocation monitoring surveys should be reviewed with reference to the baseline survey results and findings of the condition of surrounding environment. The detailed reporting requirements of the post-translocation monitoring report shall be agreed with AFCD.

10.7 Operation Phase EM&A Reporting

- 10.7.1 For the operation phase EM&A, Odour Monitoring Report on results of the odour patrol, shall be prepared and submitted. The findings of the monitoring results including methodology, data presentation, discussion, conclusion and recommendations shall be provided in the monitoring reports. Details of the reports distribution and time frame for submission shall be agreed EPD prior to commencement of works.

10.8 Data Keeping

- 10.8.1 No site-based documents (such as monitoring field records, laboratory analysis records, site inspection forms, etc.) are required to be included in the monthly EM&A reports. However, any such document shall be well kept by the ET Leader and be ready for inspection upon request. All relevant information shall be clearly and systematically recorded in the document. Monitoring data shall also be recorded in magnetic media form, and the software copy must be available upon request. Data format shall be agreed with the EPD. All documents and data shall be kept for at least one year following completion of the construction contract.

10.9 Interim Notifications of Environmental Quality Limit Exceedances

- 10.9.1 With reference to the Event and Action Plan, when the environmental quality performance limits are exceeded, the ET Leader shall immediately notify the IEC and EPD, as appropriate. The notification shall be followed up with advice to IEC and EPD on the results of the investigation, proposed actions and success of the actions taken, with any necessary follow-up proposals. A sample template for the interim notifications is presented in **Appendix C**.

Figures

LEGEND:

- DP3: EXTENT OF PERMANENT RECLAMATION
- DP3: INDICATIVE EXTENT OF TEMPORARY RECLAMATION
- DP3: DREDGING AREA FOR MITIGATION OF ODOUR

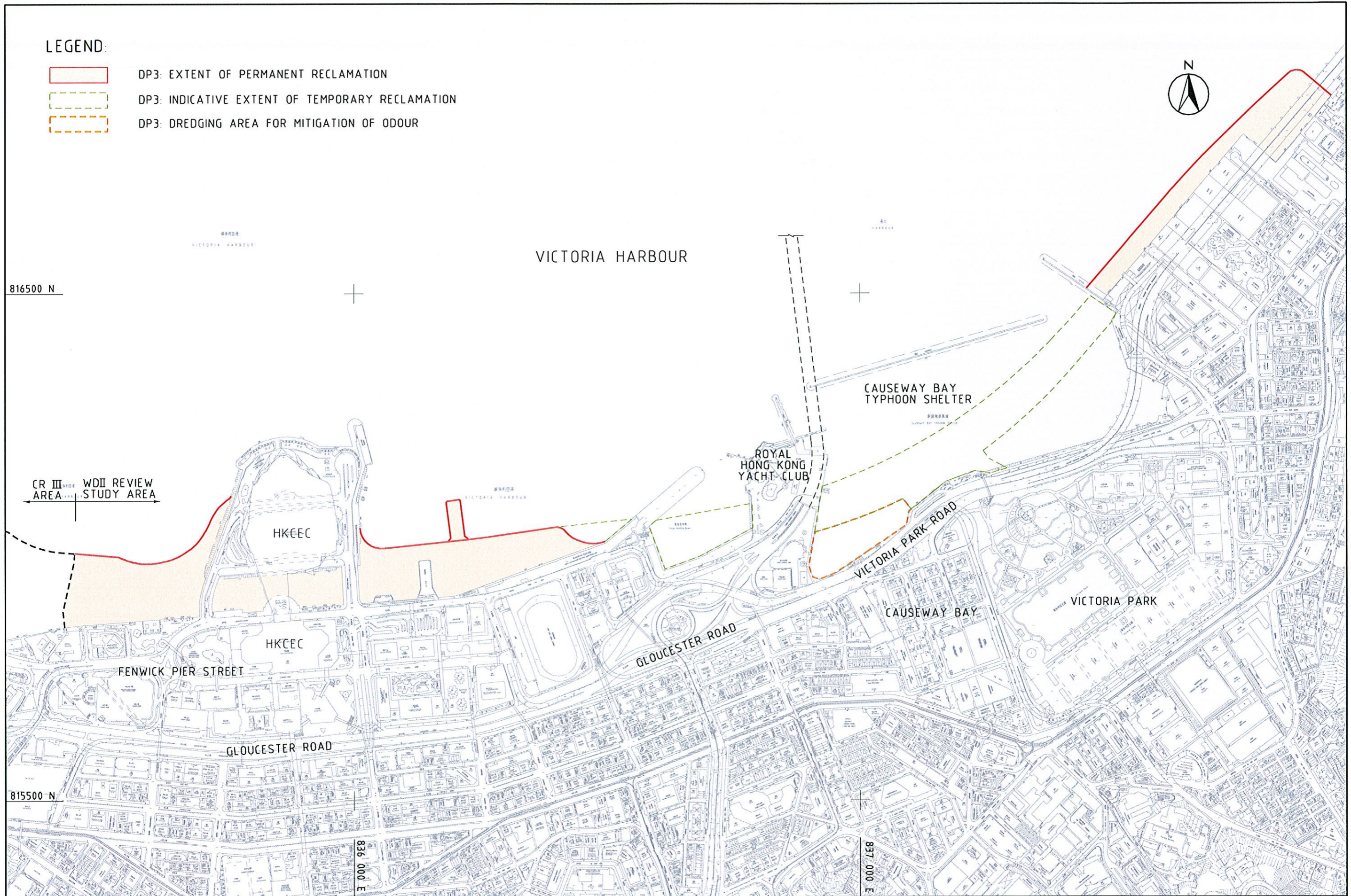

WAN CHAI DEVELOPMENT PHASE II - PLANNING AND ENGINEERING REVIEW

DESIGNATED PROJECT 3 - RECLAMATION WORKS INCLUDING ASSOCIATED DREDGING WORKS

FIGURE 1.2c

MAUNSELL | AECOM
Maunsell Consultants Asia Ltd

DATE: 2007-9-25 14:55:20

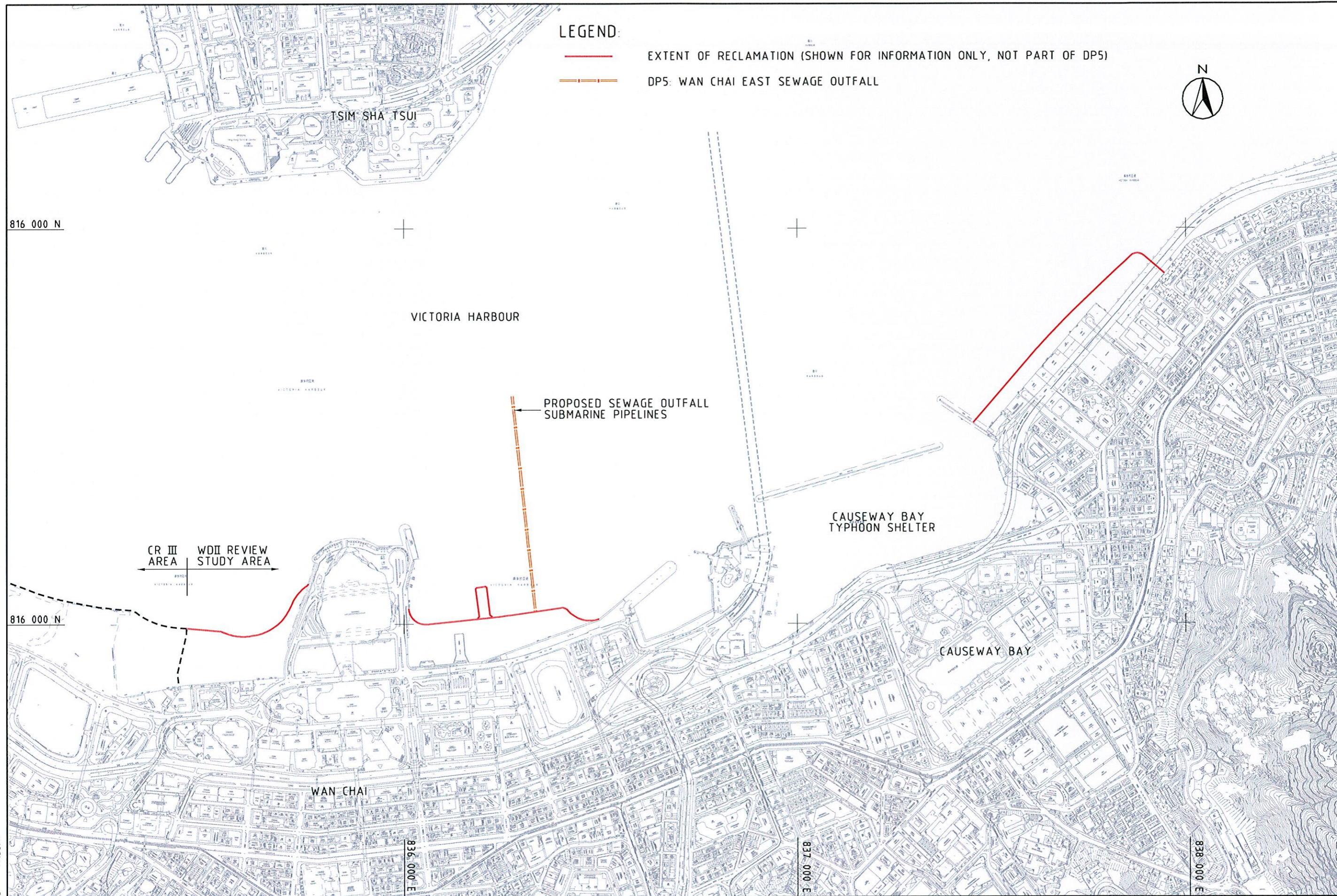

WAN CHAI DEVELOPMENT PHASE II - PLANNING AND ENGINEERING REVIEW

DESIGNATED PROJECT 5 - WAN CHAI EAST SEWAGE OUTFALL

FIGURE 1.2e

DATE: 2007-9-25 14:56:11

MAUNSELL | AECOM
Maunsell Consultants Asia Ltd

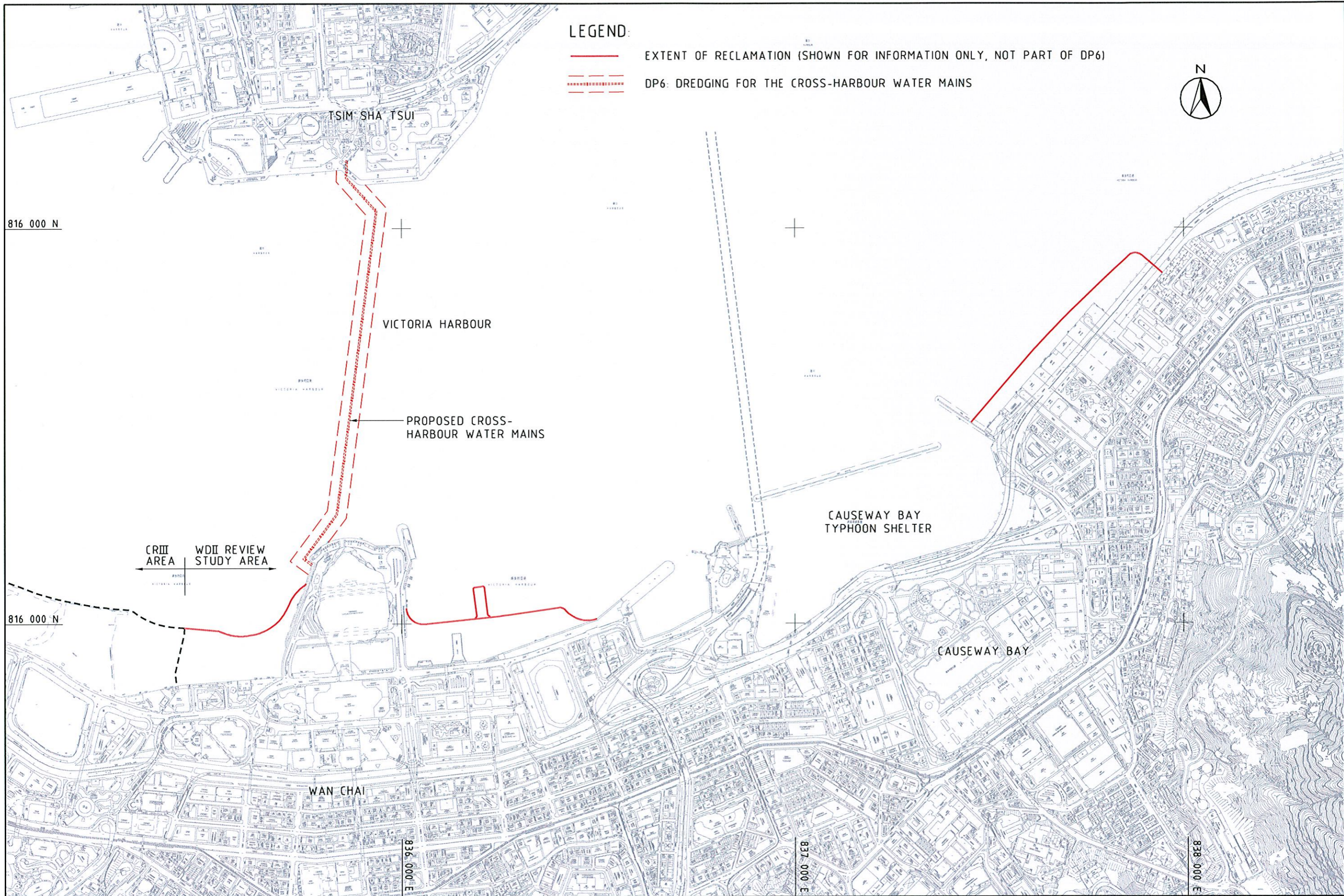

WAN CHAI DEVELOPMENT PHASE II - PLANNING AND ENGINEERING REVIEW

DESIGNATED PROJECT 6 -
DREDGING FOR THE CROSS-HARBOUR WATER MAINS FROM WAN CHAI TO TSIM SHA TSUI

FIGURE 1.2f

DATE: 2007-9-25 14:56:36

MAUNSELL | AECOM
Maunsell Consultants Asia Ltd



LEGEND:

- 500m STUDY BOUNDARY
- A51 AIR SENSITIVE RECEIVER

WAN CHAI DEVELOPMENT PHASE II - PLANNING AND ENGINEERING REVIEW
LOCATIONS OF REPRESENTATIVE AIR SENSITIVE RECEIVERS

FIGURE 2.1

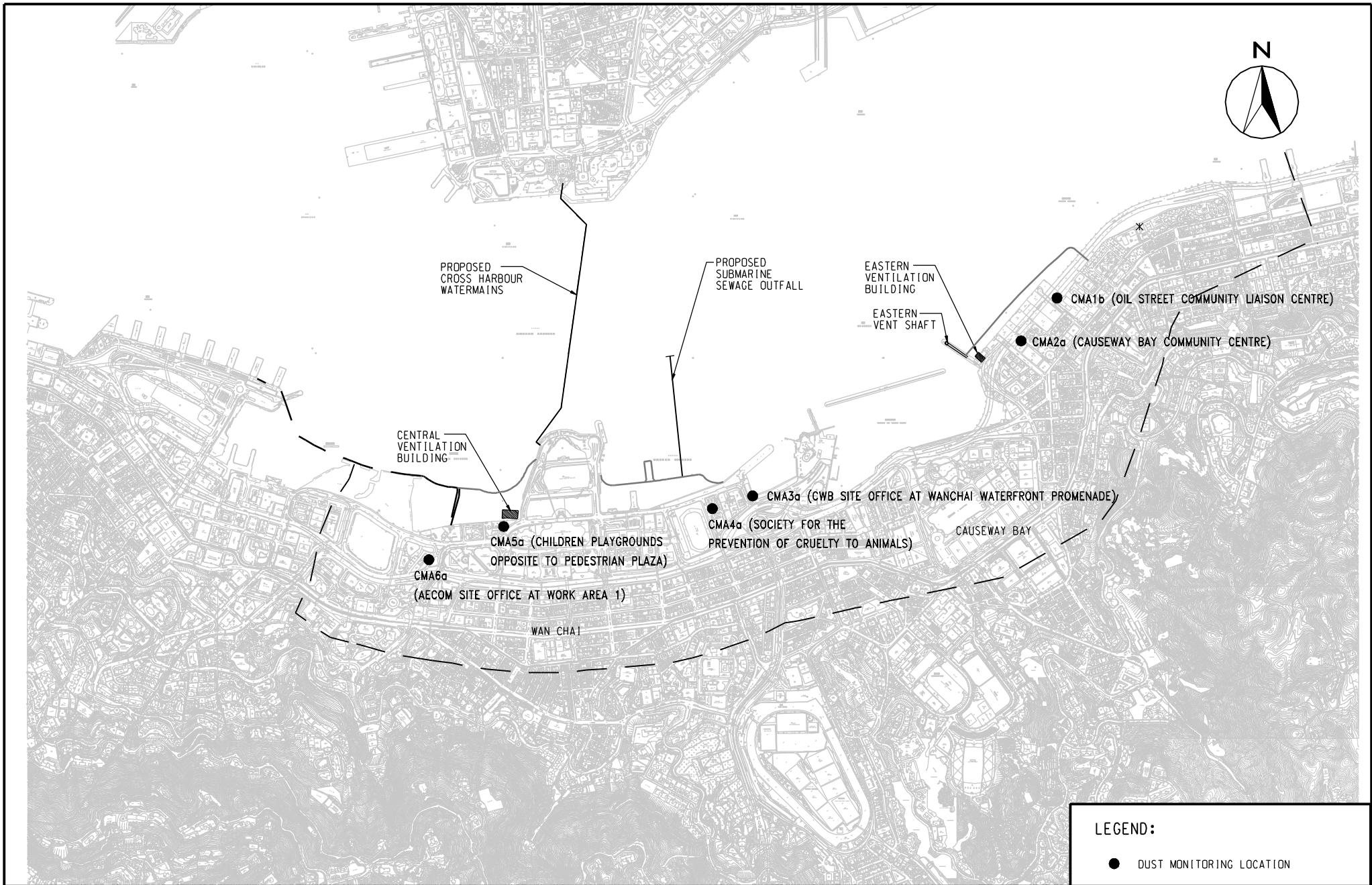

WAN CHAI DEVELOPMENT PHASE II - PLANNING AND ENGINEERING REVIEW
 PROPOSED MONITORING LOCATIONS DURING CONSTRUCTION PHASE

FIGURE 2.2

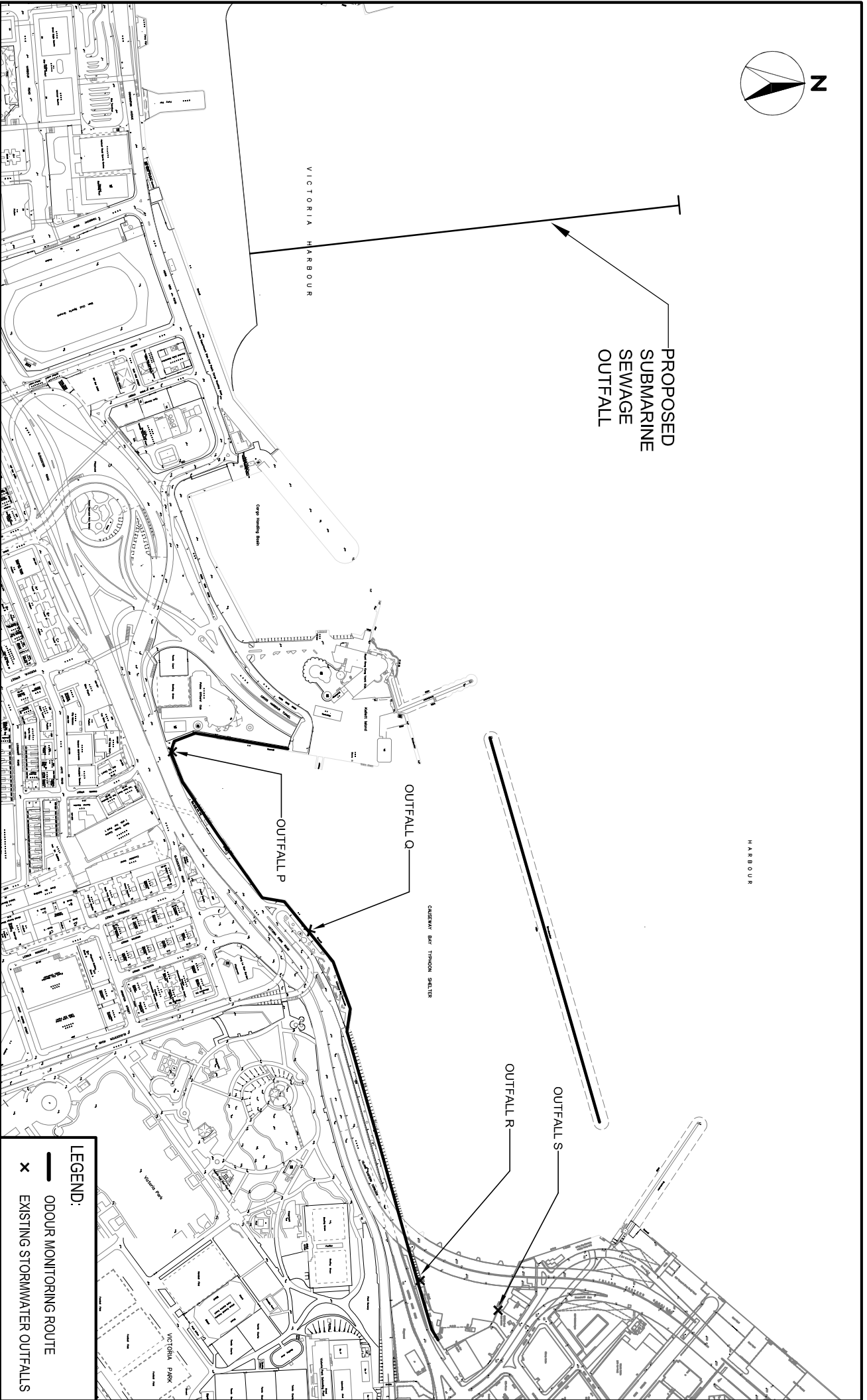

WAN CHAI DEVELOPMENT PHASE II - PLANNING AND ENGINEERING REVIEW

PROPOSED ODOUR MONITORING ROUTE
DURING OPERATION PHASE

FIGURE 2.3

NSR	Description	Use	No. of Floors
N1	HKAPA (Open Arena)	Performing Arts Centre	G/F
N2	Causeway Centre	Residential	42
N3	Gloucester Road 169-170	Residential	12
N4	Kam Kwok Building	Residential	18
N5	Hyde Centre	Residential	22
N6	Elizabeth House	Residential	21
N7	Riviera Mansion	Residential	15
N8	Marco Polo Mansion	Residential	15
N9	Viking Garden	Residential	25
N10	Victoria Court	Residential	18
N11	Mayson Garden	Residential	24
N12	Gordon House	Residential	15
N13	Belle House	Residential	24
N14	Hoi Tao Building	Residential	30
N15	Staff Quarters of FEHD	Residential	4
N16	Victoria Centre	Residential	30
N17	Harbour Heights	Residential	44
N17-A	Harbour Heights	Residential	44
N18	City Garden, Block 10	Residential	27
N18-A	City Garden, Block 11	Residential	27
N18-B	City Garden, Block 10	Residential	27
N19	City Garden, Block 7	Residential	27
N19-A	City Garden, Block 7	Residential	27
N20	Hong Kong Baptist Church Henrietta Secondary School	Educational Institution	6
N21	Provident Centre, Block 1	Residential	25
N22	Provident Centre, Block 6	Residential	25
N23	Provident Centre, Block 17	Residential	25
P1-A	Planned location for Re-provisioned Tin Hau Temple (West Facing Façade)	Temple	1
P1-B	Planned location for Re-provisioned Tin Hau Temple (South Facing Façade)	Temple	1
P2	A land zoned as "CDA(1)" near Oil Street	CDA(1)	53
P3	A land zoned as CDA near Oil Street	CDA	34



LEGEND:

- N1-N23 EXISTING NOISE SENSITIVE RECEIVER
- P1-P3 PLANNED NOISE SENSITIVE RECEIVER
- 300M STUDY BOUNDARY

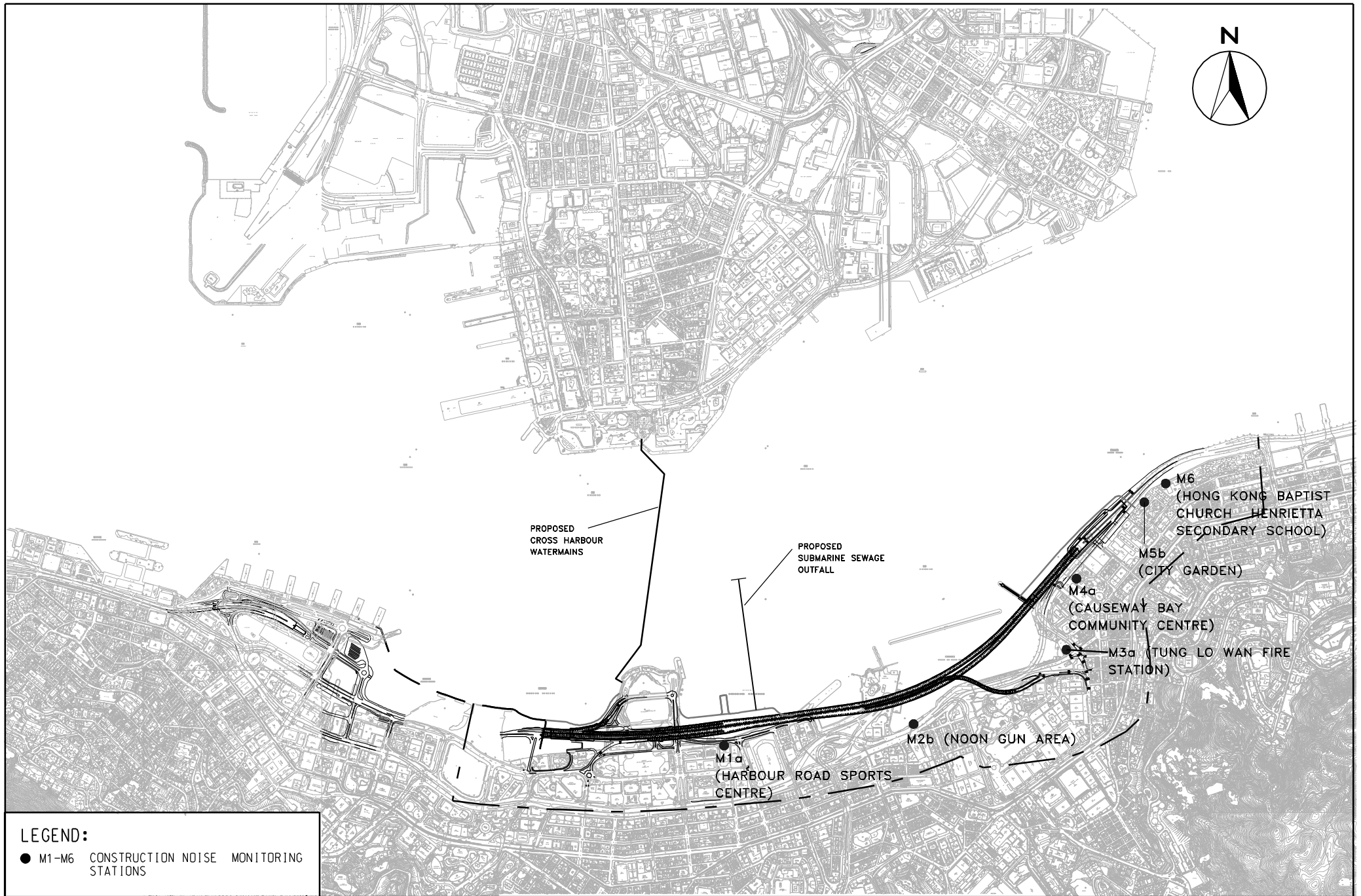

WAN CHAI DEVELOPMENT PHASE II - PLANNING AND ENGINEERING REVIEW

LOCATIONS OF CONSTRUCTION NOISE MONITORING STATIONS

FIGURE 3.2

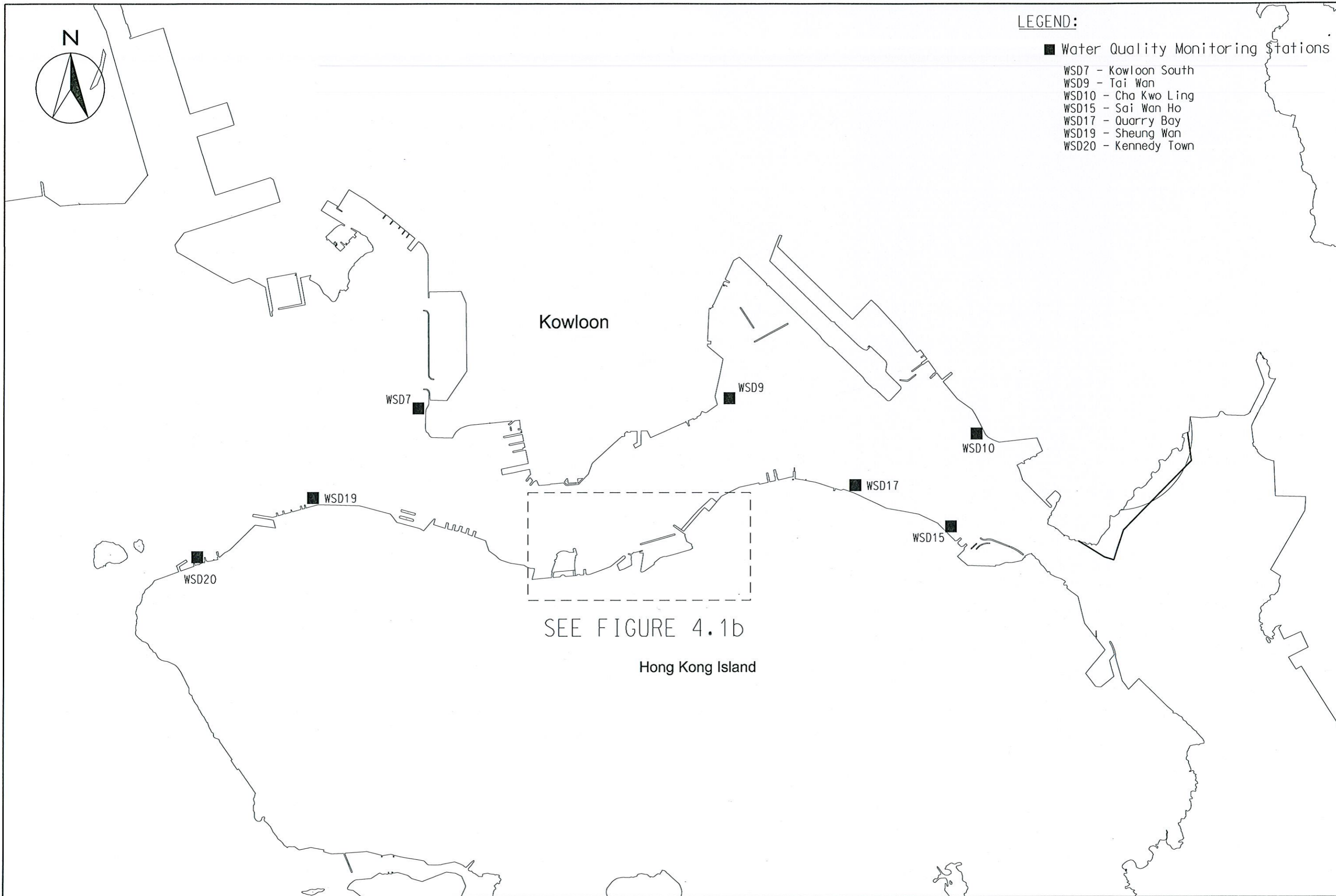

LEGEND:

WATER QUALITY MONITORING STATIONS

- C1 HONG KONG CONVENTION AND EXHIBITION CENTRE EXTENSION
- C2 TELECOM HOUSE/HK ACADEMY FOR PERFORMING/ SHUI ON CENTRE
- C3 HONG KONG CONVENTION AND EXHIBITION CENTRE PHASE I
- C4 WAN CHAI TOWER AND GREAT EAGLE CENTRE
- C5 SUN HUNG KAI CENTRE
- C6 WORLD TRADE CENTRE
- C7 WINDSOR HOUSE
- C8 CITY GARDEN
- C9 PROVIDENT CENTRE
- RC1 PROPOSED HKAPA EXTENSION
- RC5 SUN HUNG KAI CENTRE (REPROVISION)
- RC7 WINDSOR HOUSE (TEMPORARY REPROVISION)
- WSD21 WAN CHAI
- RW21 WAN CHAI (REPROVISION)

MONITORING STATIONS FOR ENHANCED WATER QUALITY MONITORING AND AUDIT PROGRAMME

- C6 WORLD TRADE CENTRE
- C7 WINDSOR HOUSE
- EX-WPCWA SW SOUTH-WEST CORNER OF EX-PCWA
- EX-WPCWA SE SOUTH-EAST CORNER OF EX-PCWA

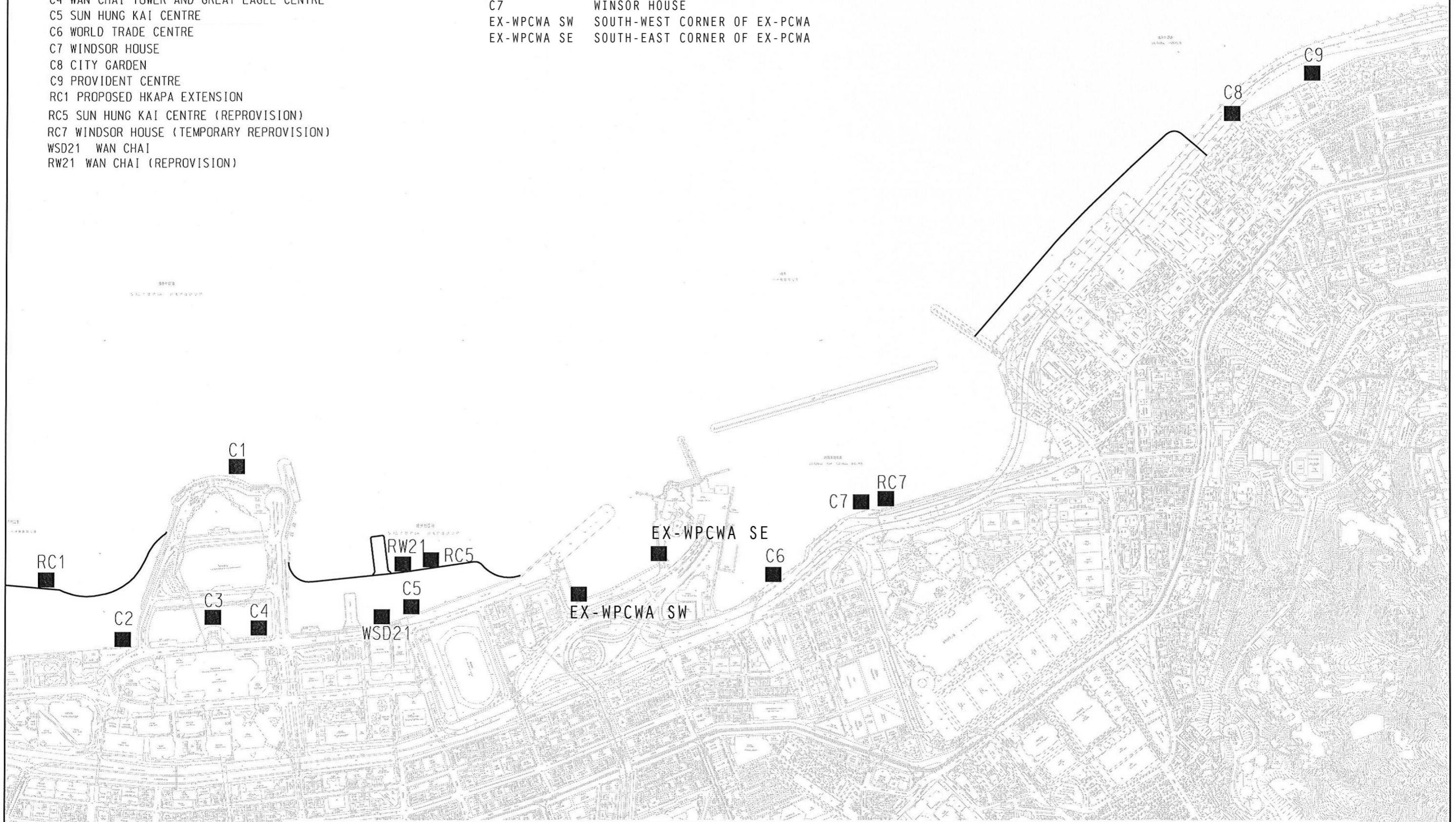

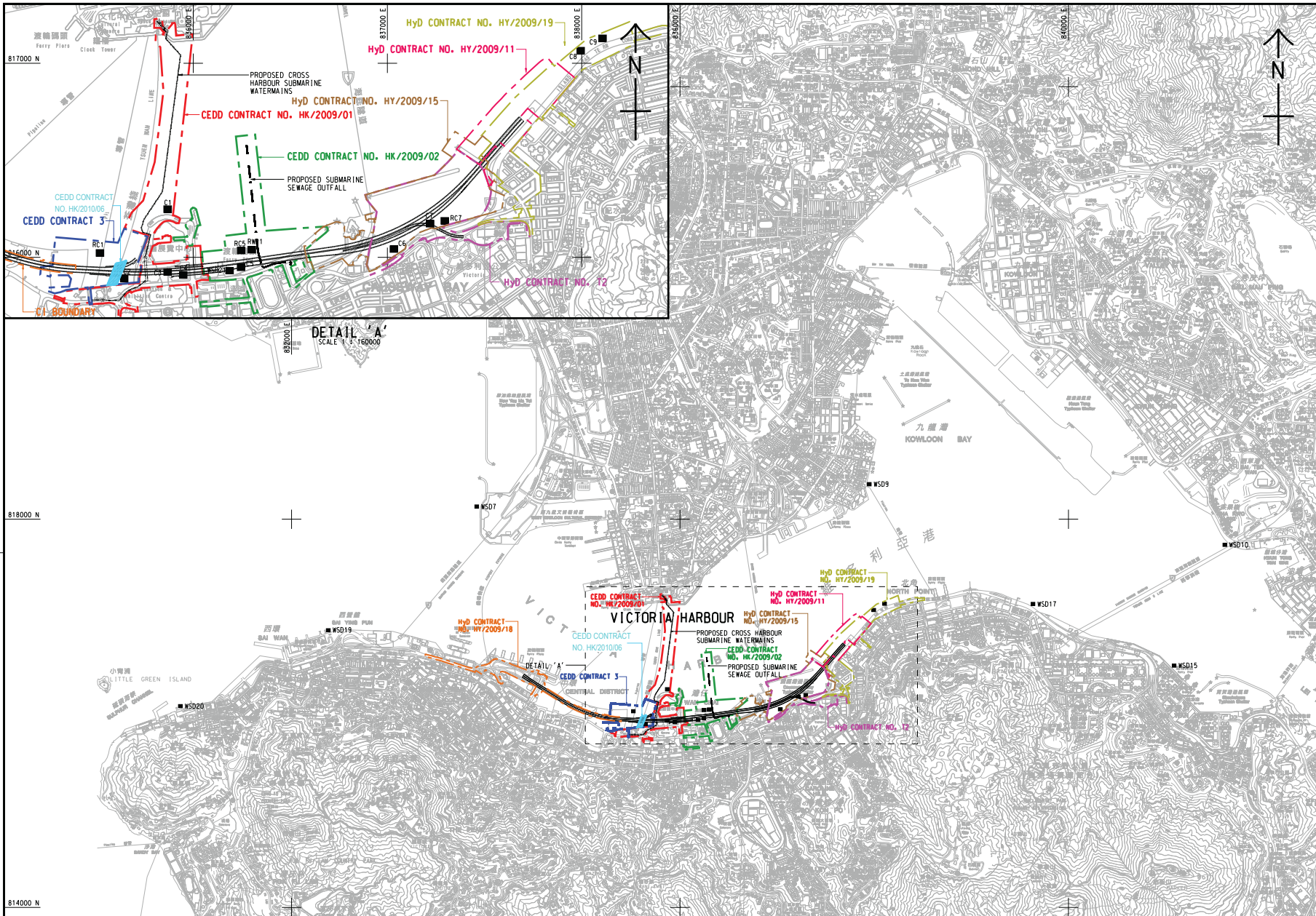

- LEGEND:**
- WATER QUALITY MONITORING STATIONS
- COOLING WATER INTAKES**
- C1 HONG KONG CONVENTION AND EXHIBITION CENTRE EXTENSION
 - C2 TELECOM HOUSE/HK ACADEMY FOR PERFORMING ARTS / SHUI ON CENTRE
 - C3 HONG KONG CONVENTION AND EXHIBITION CENTRE PHASE I
 - C4 WAN CHAI TOWER AND GREAT EAGLE CENTRE
 - C5 SUN HUNG KAI CENTRE
 - C6 PROPOSED EXHIBITION STATION / WORLD TRADE CENTRE
 - C7 WINDSOR HOUSE
 - C8 CITY GARDEN
 - C9 PROVIDENT CENTRE
 - C01 PROPOSED HKAPA EXTENSION
 - RC5 SUN HUNG KAI CENTRE (REPROVISION)
 - RC7 WINDSOR HOUSE (TEMPORARY REPROVISION)
- WSD SALT WATER INTAKE**
- WSD21 WAN CHAI
 - RW21 WAN CHAI (REPROVISION)
 - WSD7 KOWLOON SOUTH
 - WSD9 TAI WAN
 - WSD10 CHA KWO LING
 - WSD15 SAI WAN HD
 - WSD17 QUARRY BAY
 - WSD19 SHEUNG WAN
 - WSD20 KENNEDY TOWN

REV. NO.	DESCRIPTION	DATE



WAN CHAI DEVELOPMENT PHASE II

WAN CHAI BYPASS - SAMPLING, FIELD MEASUREMENT AND TESTING WORKS (STAGE 1)

LOCATIONS OF WATER QUALITY MONITORING STATIONS



DESIGNATED PROJECTS (DP)
DP1 - CENTRAL-WAN CHAI BYPASS (CWB) INCLUDING ITS ROAD TUNNEL AND SLIP ROADS
DP2 - ROAD P2 AND OTHER ROADS (PRIMARY / DISTRICT DISTRIBUTOR ROADS)
DP3 - PERMANENT AND TEMPORARY RECLAMATION WORKS INCLUDING ASSOCIATED DREDGING WORKS IN WAN CHAI DEVELOPMENT PHASE II (WD11) AREA
DP4 - TEMPORARY-TYPHOON-SHELTER (DP4 NOT TO BE IMPLEMENTED)
DP5 - WAN CHAI EAST SEWAGE OUTFALL
DP6 - DREDGING FOR THE CROSS-HARBOUR WATER MAINS

WORKS CONTRACT	DESIGNATED PROJECT INVOLVED	CONSTRUCTION COMMENCEMENT
CEDD CONTRACT NO. HK/2009/01	DP1, DP3, DP6	APRIL 2010
CEDD CONTRACT NO. HK/2009/02	DP1, DP3, DP5	APRIL 2010
CEDD CONTRACT 3	DP1, DP3	LATE OF 2012
CEDD CONTRACT NO. HK/2010/06	DP1, DP3	JAN 2011
CEDD CONTRACT 5	DP2	2015
Hyd CONTRACT NO. HY/2009/11	DP3	18 MARCH 2010
Hyd CONTRACT NO. HY/2009/15	DP1, DP3	SEPTEMBER 2010
Hyd CONTRACT NO. HY/2009/18	DP1	OCTOBER 2010
Hyd CONTRACT NO. HY/2009/19	DP1	JAN 2011
Hyd CONTRACT 12	DP1, DP3	MID 2013

Plot File By : 2010-3-17 CHEUNG

DRGNO. 圖紙編號 FIG 4.1 C

DESIGNED BY 設計人: AWSY	CONTRACT NO. 合約編號	P. E. APPROVED 專業校核: BEX
DRAWN BY 繪圖人: ADC	STATUS 狀態	PMC
SCALE 比例尺: A1 1:20000	DRAWING UNIT 圖紙單位: METRES	

© COPYRIGHT RESERVED 版權所有

LEGEND:

- PROPOSED PERMANENT RECLAMATION AREA
- PROPOSED TEMPORARY RECLAMATION AREA
- CORAL SPOT-CHECK SURVEY AREA
- SPOT-CHECK DIVE ROUTE



WAN CHAI DEVELOPMENT PHASE II - PLANNING AND ENGINEERING REVIEW

SPOT-CHECK DIVE SITES AND REA TRANSECTS

(SHEET 1 OF 2)

FIGURE 7.1

2007-8-9

LEGEND:

- PROPOSED PERMANENT RECLAMATION
- PROPOSED TEMPORARY RECLAMATION
- CORAL SPOT-CHECK SURVEY AREA
- SPOT-CHECK DIVE ROUTE
- TEMPORARY PILED WAVE WALL
- INTERTIDAL COMMUNITIES SURVEY SITE

MATCHLINE

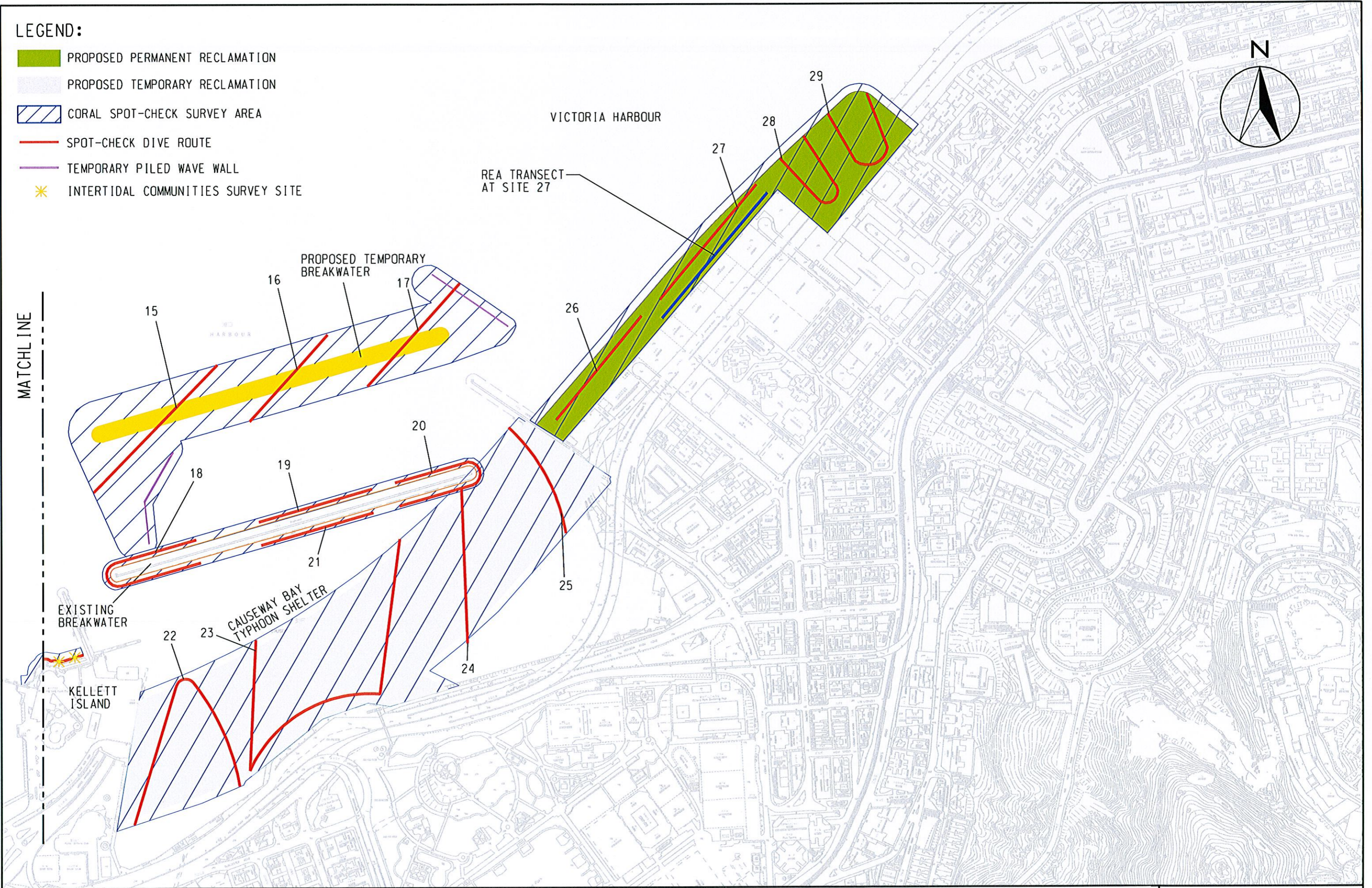

WAN CHAI DEVELOPMENT PHASE II - PLANNING AND ENGINEERING REVIEW

SPOT-CHECK DIVE SITES AND REA TRANSECTS

(SHEET 2 OF 2)

FIGURE 7.2

2007-8-9

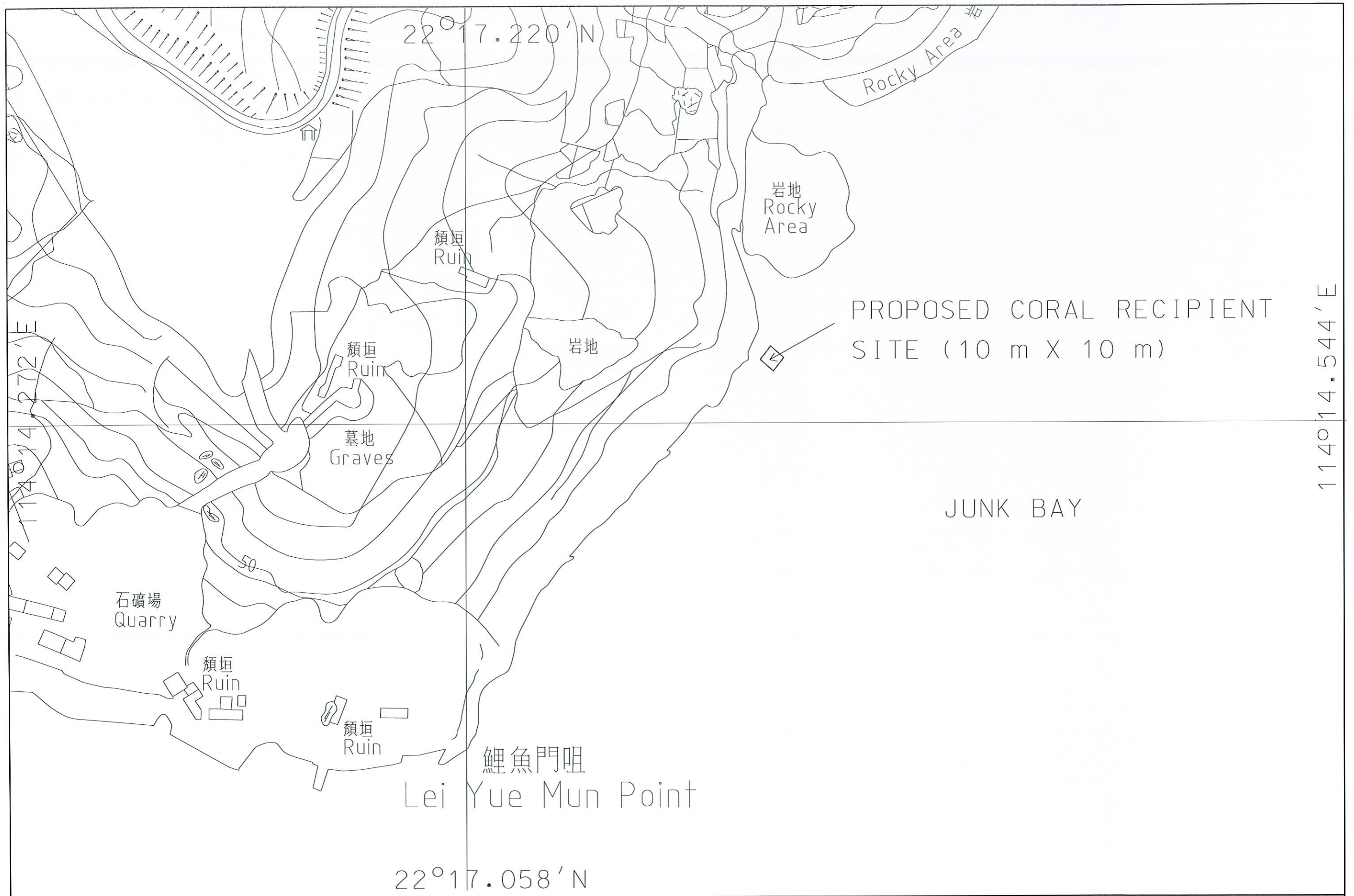

KEY FOR LANDSCAPE RESOURCES

- LR1 Natural Coastline at the BRIDGE at Kowloon Island
- LR1A Victoria Harbour
- LR2 Aerial View of Open Space
- LR3 Aerial View of Open Space
- LR4 Grand Hyatt Hotel Public Plaza Open Space
- LR5 Hong Kong Convention and Exhibition Centre Powerade
- LR6 Central Plaza Open Space
- LR7 Harbour Road Gardens
- LR8 Harbour Road Gardens
- LR9 Cross Harbour Tunnel Entrance Area
- LR10 Tsunami Approach East Garden
- LR11 Tree Planting adjacent to Sewage Works, Hung Hong Road
- LR12 Wetland Area along Causeway Bay Typhoon Shelter
- LR13 Wetland Area along Causeway Bay Typhoon Shelter
- LR14 Wetland Area along Causeway Bay Typhoon Shelter
- LR15 Wetland Area along Causeway Bay Typhoon Shelter
- LR16 Wetland Area along Causeway Bay Typhoon Shelter
- LR17 Wetland Area along Causeway Bay Typhoon Shelter
- LR18 Wetland Area along Causeway Bay Typhoon Shelter
- LR19 Wetland Area along Causeway Bay Typhoon Shelter
- LR20 Wetland Area along Causeway Bay Typhoon Shelter
- LR21 Wetland Area along Causeway Bay Typhoon Shelter
- LR22 Wetland Area along Causeway Bay Typhoon Shelter

LEGEND

- PLANNING AND ENGINEERING REVIEW STUDY AREA BOUNDARY
- LANDSCAPE IMPACT STUDY BOUNDARY
- LANDSCAPE RESOURCES
- PHOTO TAKING POINT WITH PHOTO NO.
- CENTRAL-WANCHAI BYPASS (CWB) INCLUDING ITS ROAD TUNNEL AND SLIP ROADS
- ROAD P2 AND OTHER ROADS WHICH ARE CLASSIFIED AS PRIMARY/DISTRICT DISTRIBUTOR ROADS
- RECLAMATION WORKS INCLUDING ASSOCIATED DREDGING WORKS

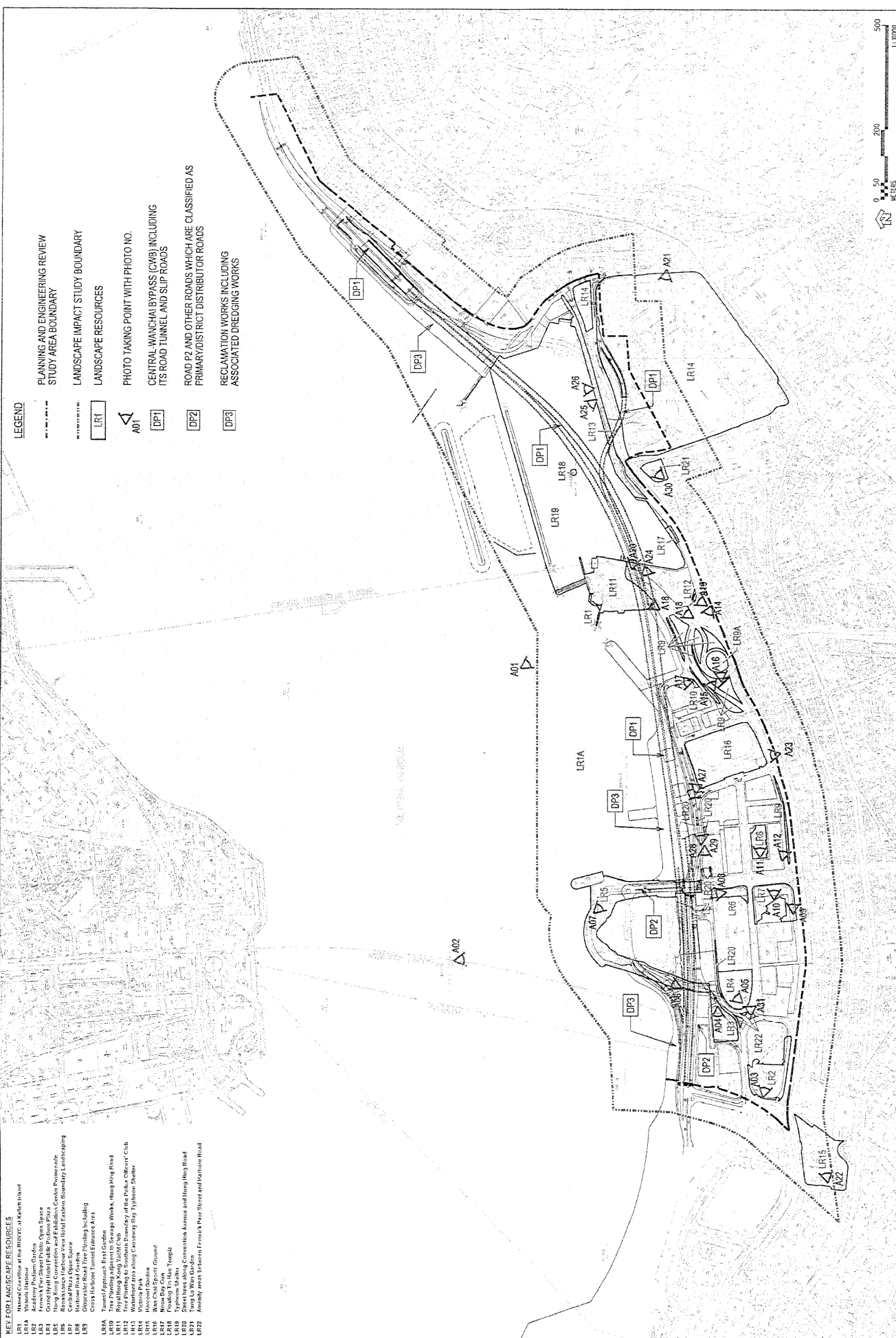

KEY FOR LANDSCAPE RESOURCES

- LR1 Natural Coastline at the RHKYC at Kellett Island
- LR1A Victoria Harbour
- LR2 Academy Podium Garden
- LR4 Grand Hyatt Hotel Public Podium Plaza
- LR5 Hong Kong Convention and Exhibition Centre Promenade
- LR6 Renaissance Harbour View Hotel Eastern Boundary Landscaping
- LR7 Central Plaza Open Space
- LR8 China Resources Building Garden
- LR9 Gloucester Road Tree Planting including Cross Harbour Tunnel Entrance Area
- LR9A Tunnel Approach Rest Garden
- LR10 Tree Planting adjacent to Sewage Works, Hung Hing Road
- LR11 Royal Hong Kong Yacht Club
- LR12 Tree Planting to Southern Boundary of the Police Officers' Club
- LR13 Waterfront area along Causeway Bay Typhoon Shelter
- LR14 Victoria Park
- LR15 Harcourt Garden
- LR16 Wan Chai Sports Ground
- LR17 Noon Day Gun
- LR18 Floating Tin Hau Temple
- LR19 Typhoon Shelter
- LR20 Street trees along Convention Avenue and Hung Hing Road
- LR21 Tung Lo Wan Garden
- LR22 Amenity Area between Fenwick Peer Street & Harbour Road
- LR23 Planned Open Space for Street Market with Outdoor Performance Area
- LR24 Planned Waterfront Regional Open Space
- LR25 Planned Kiosks and Leisure Boating Area, and Water Sport Centre
- LR26 Planned Waterfront Park

LEGEND

- PLANNING AND ENGINEERING REVIEW STUDY AREA BOUNDARY
- LANDSCAPE IMPACT STUDY BOUNDARY
- LR1 LANDSCAPE RESOURCES
- ▲ A01 PHOTO TAKING POINT WITH PHOTO NO.
- DP1 CENTRAL-WANCHAI BYPASS (CWB) INCLUDING ITS ROAD TUNNEL AND SLIP ROADS
- DP2 ROAD P2 AND OTHER ROADS WHICH ARE CLASSIFIED AS PRIMARY/DISTRICT DISTRIBUTOR ROADS
- DP3 RECLAMATION WORKS INCLUDING ASSOCIATED DREDGING WORKS

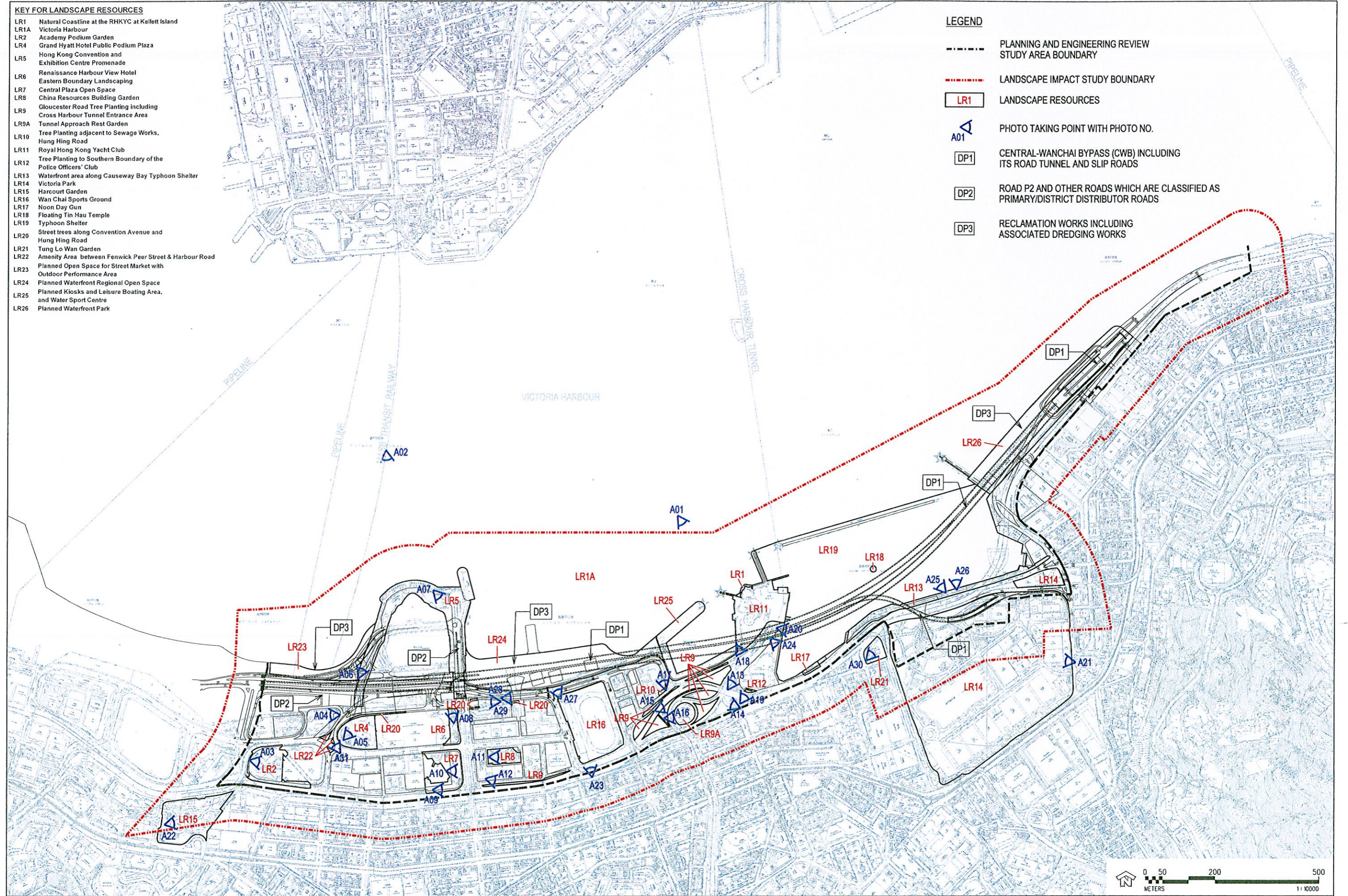

WAN CHAI DEVELOPMENT PHASE II - PLANNING AND ENGINEERING REVIEW

BASELINE LANDSCAPE RESOURCES DURING OPERATION

FIGURE 8.1b

- KEY FOR LANDSCAPE CHARACTER AREA**
- LZ1 Fleet Arcade / Wan Chai West Sewage Screening Plant
 - LZ2 The Hong Kong Academy for Performing Arts (HKAPA) Public Open Space
 - LZ3 The HKCEC Open Space
 - LZ4 The HKCEC Grand Hyatt /
 - LZ5 Renaissance Harbour View Hotel
 - LZ6 Renaissance Harbour View Plaza
 - LZ7 The Hong Kong Convention and Exhibition Centre
 - LZ8 The Hong Kong Convention and Exhibition Centre Extension Open Space
 - LZ9 Government Towers / Shell Oil Centre
 - LZ10 Central Plaza Open Space
 - LZ11 China Resources Building / Sun Hung Kai Centre
 - LZ12 Harbour Road Garden
 - LZ13 Public Transport Interchange (PTI)
 - LZ14 Harbour Road Sports Centre and Swimming Complex
 - LZ15 Wan Chai Ferry Pier
 - LZ16 Wan Chai Sports Ground
 - LZ17 Admiralty Government Offices
 - LZ18 Admiralty Government Offices
 - LZ19 Admiralty Government Offices
 - LZ20 Admiralty Government Offices
 - LZ21 Admiralty Government Offices
 - LZ22 Admiralty Government Offices
 - LZ23 Admiralty Government Offices
 - LZ24 Admiralty Government Offices
 - LZ25 Admiralty Government Offices
 - LZ26 Admiralty Government Offices
 - LZ27 Admiralty Government Offices
 - LZ28 Admiralty Government Offices
 - LZ29 Admiralty Government Offices
 - LZ30 Admiralty Government Offices
 - LZ31 Admiralty Government Offices
 - LZ32 Admiralty Government Offices
 - LZ33 Admiralty Government Offices
 - LZ34 Admiralty Government Offices
 - LZ35 Admiralty Government Offices
 - LZ36 Admiralty Government Offices
 - LZ37 Admiralty Government Offices
 - LZ38 Admiralty Government Offices
 - LZ39 Admiralty Government Offices
 - LZ40 Admiralty Government Offices
 - LZ41 Admiralty Government Offices
 - LZ42 Admiralty Government Offices
 - LZ43 Admiralty Government Offices
 - LZ44 Admiralty Government Offices
 - LZ45 Admiralty Government Offices
 - LZ46 Admiralty Government Offices
 - LZ47 Admiralty Government Offices
 - LZ48 Admiralty Government Offices
 - LZ49 Admiralty Government Offices
 - LZ50 Admiralty Government Offices
 - LZ51 Admiralty Government Offices
 - LZ52 Admiralty Government Offices
 - LZ53 Admiralty Government Offices
 - LZ54 Admiralty Government Offices
 - LZ55 Admiralty Government Offices
 - LZ56 Admiralty Government Offices
 - LZ57 Admiralty Government Offices
 - LZ58 Admiralty Government Offices
 - LZ59 Admiralty Government Offices
 - LZ60 Admiralty Government Offices
 - LZ61 Admiralty Government Offices
 - LZ62 Admiralty Government Offices
 - LZ63 Admiralty Government Offices
 - LZ64 Admiralty Government Offices
 - LZ65 Admiralty Government Offices
 - LZ66 Admiralty Government Offices
 - LZ67 Admiralty Government Offices
 - LZ68 Admiralty Government Offices
 - LZ69 Admiralty Government Offices
 - LZ70 Admiralty Government Offices
 - LZ71 Admiralty Government Offices
 - LZ72 Admiralty Government Offices
 - LZ73 Admiralty Government Offices
 - LZ74 Admiralty Government Offices
 - LZ75 Admiralty Government Offices
 - LZ76 Admiralty Government Offices
 - LZ77 Admiralty Government Offices
 - LZ78 Admiralty Government Offices
 - LZ79 Admiralty Government Offices
 - LZ80 Admiralty Government Offices
 - LZ81 Admiralty Government Offices
 - LZ82 Admiralty Government Offices
 - LZ83 Admiralty Government Offices
 - LZ84 Admiralty Government Offices
 - LZ85 Admiralty Government Offices
 - LZ86 Admiralty Government Offices
 - LZ87 Admiralty Government Offices
 - LZ88 Admiralty Government Offices
 - LZ89 Admiralty Government Offices
 - LZ90 Admiralty Government Offices
 - LZ91 Admiralty Government Offices
 - LZ92 Admiralty Government Offices
 - LZ93 Admiralty Government Offices
 - LZ94 Admiralty Government Offices
 - LZ95 Admiralty Government Offices
 - LZ96 Admiralty Government Offices
 - LZ97 Admiralty Government Offices
 - LZ98 Admiralty Government Offices
 - LZ99 Admiralty Government Offices
 - LZ100 Admiralty Government Offices

- LEGEND**
- PLANNING AND ENGINEERING REVIEW STUDY AREA BOUNDARY
 - LANDSCAPE CHARACTER AREA
 - LANDSCAPE IMPACT STUDY BOUNDARY
 - LANDSCAPE CHARACTER AREA
 - CENTRAL WANCHAI BYPASS (CWB) INCLUDING ITS ROAD TUNNEL AND SLIP ROADS
 - ROAD P2 AND OTHER ROADS WHICH ARE CLASSIFIED AS PRIMARY/DISTRICT DISTRIBUTOR ROADS
 - RECLAMATION WORKS INCLUDING ASSOCIATED DREDGING WORKS

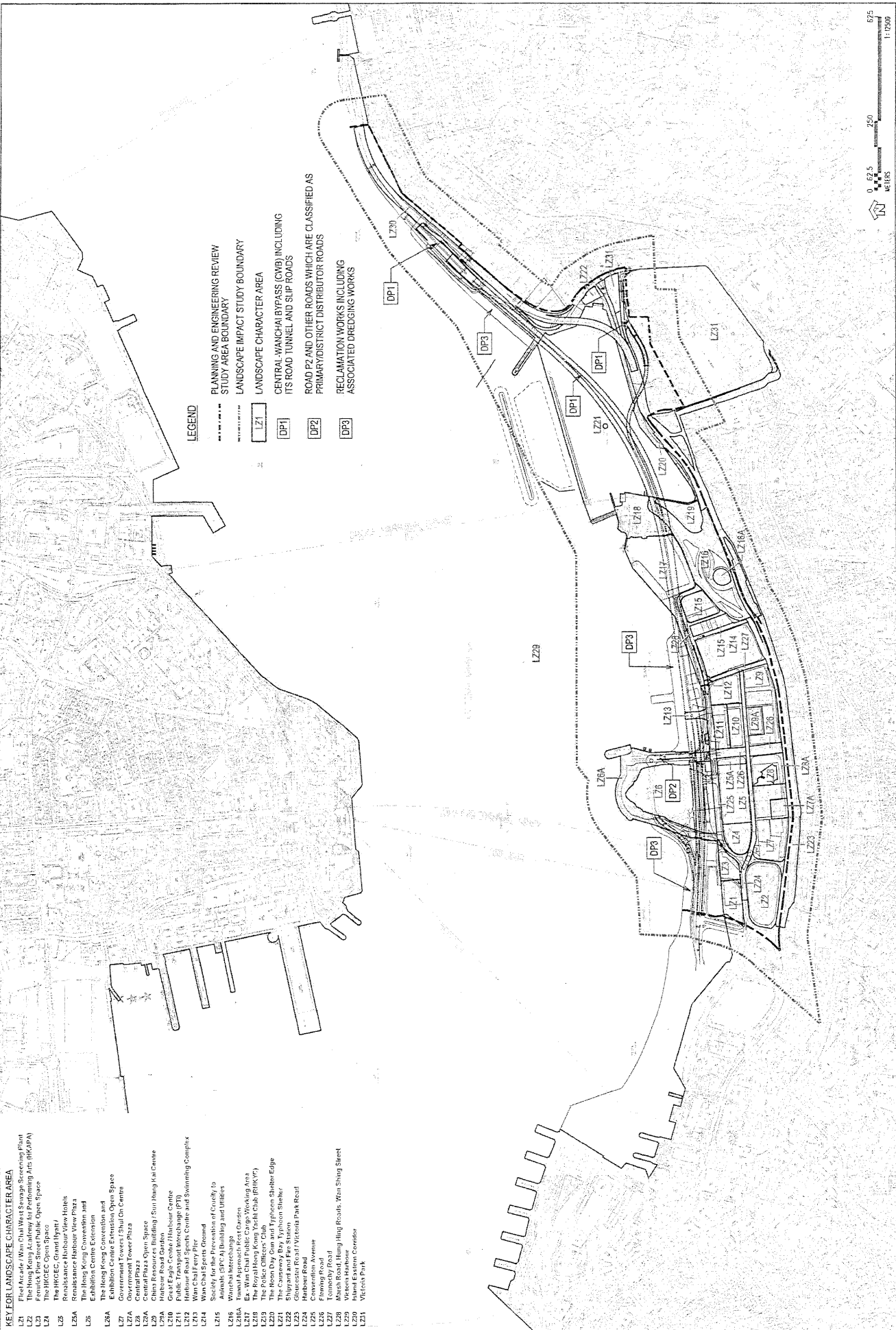

KEY FOR LANDSCAPE CHARACTER AREA

- LZ2 The Hong Kong Academy for Performing Arts (HKAPA)
- LZ4 The HKCEC Open Space
- LZ5 The HKCEC, Grand Hyatt / Renaissance Harbour View Hotels
- LZ5A Renaissance Harbour View Plaza
- LZ6 The Hong Kong Convention and Exhibition Centre Extension
- LZ6A The Hong Kong Convention and Exhibition Centre Extension Open Space
- LZ7 Government Towers / Shui On Centre
- LZ7A Government Tower Plaza
- LZ8 Central Plaza
- LZ8A Central Plaza Open Space
- LZ9 China Resources Building / Sun Hung Kai Centre
- LZ9A Harbour Road Garden
- LZ10 Great Eagle Centre / Harbour Centre
- LZ11 Public Transport Interchange (PTI)
- LZ12 Harbour Road Sports Centre and Swimming Complex
- LZ13 Wan Chai Ferry Pier
- LZ14 Wan Chai Sports Ground
- LZ15 Society for the Prevention of Cruelty to Animals (SPCA) Building and Utilities
- LZ16 Wanchai Interchange
- LZ16A Tunnel Approach Rest Garden
- LZ17 Ex - Wan Chai Public Cargo Working Area
- LZ18 The Royal Hong Kong Yacht Club (RHKYC)
- LZ19 The Police Officers' Club
- LZ20 The Noon Day Gun and Typhoon Shelter Edge
- LZ21 The Causeway Bay Typhoon Shelter
- LZ22 Shipyard and Fire Station
- LZ23 Gloucester Road / Victoria Park Road
- LZ24 Harbour Road
- LZ25 Convention Avenue
- LZ26 Fleming Road
- LZ27 Tonnochy Road
- LZ28 Marsh Road, Hung Hing Roads, Wan Shing Street
- LZ29 Victoria Harbour
- LZ30 Island Eastern Corridor
- LZ31 Victoria Park
- LZ32 Fleet Arcade and Planned HKAPA Extension and Open Space
- LZ33 Planned Open Space for Street Market with Outdoor Performance Area
- LZ34 Planned Waterfront Regional Open Space
- LZ35 Planned Waterfront Park
- LZ36 Planned Regional Open Space

LEGEND

- PLANNING AND ENGINEERING REVIEW STUDY AREA BOUNDARY
- LANDSCAPE IMPACT STUDY BOUNDARY
- LZ1 LANDSCAPE CHARACTER AREA
- DP1 CENTRAL-WANCHAI BYPASS (CWB) INCLUDING ITS ROAD TUNNEL AND SLIP ROADS
- DP2 ROAD P2 AND OTHER ROADS WHICH ARE CLASSIFIED AS PRIMARY/DISTRICT DISTRIBUTOR ROADS
- DP3 RECLAMATION WORKS INCLUDING ASSOCIATED DREDGING WORKS

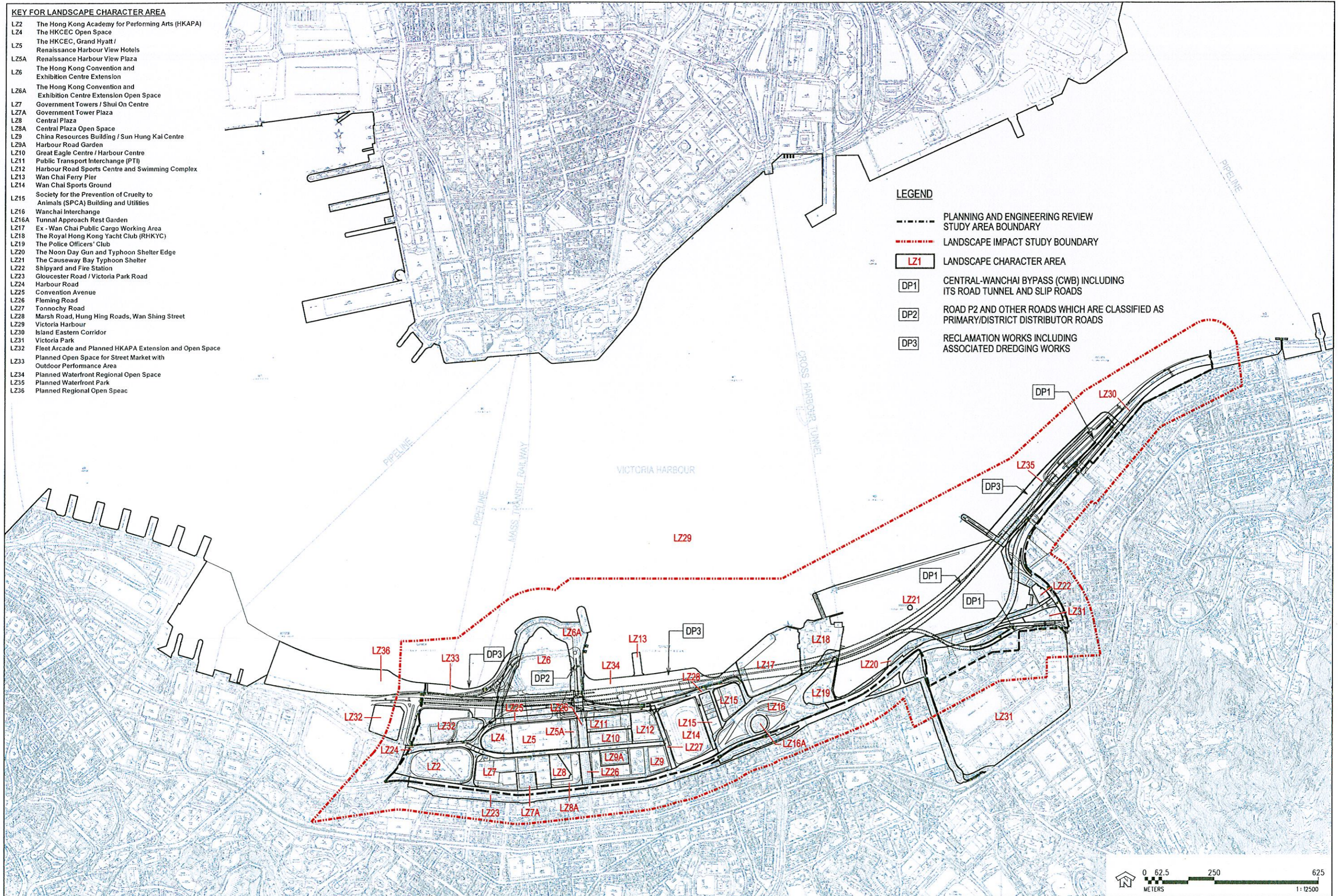

WAN CHAI DEVELOPMENT PHASE II - PLANNING AND ENGINEERING REVIEW

BASELINE LANDSCAPE CHARACTER AREAS DURING OPERATION

FIGURE 8.2b

- KEY FOR VISUAL SENSITIVE RECEIVERS**
- C1 International Finance Centre
 - C2 Hong Kong Station Development Phase 2
 - C3 Exchange Square
 - C4 Jardine House
 - C5 Andrew Hing
 - C6 Hong Kong Club
 - C7 RIZ Carlton Hotel
 - C8 AIA Tower
 - C9 Bank of America Tower
 - C10 Fair East Financial Centre
 - C11 United Centre
 - C12 United Centre
 - C13 United Centre
 - C14 United Centre
 - C15 United Centre
 - C16 Asian House
 - C17 Chung Nam Building
 - C18 Flat House, Harcourt House
 - C19 Flat House, Harcourt House
 - C20 Flat House, Harcourt House
 - C21 Shui On Centre
 - C22 Grand Hyatt Hotel
 - C23 Renaissance Harbour View Hotel
 - C24 Renaissance Harbour View Hotel
 - C25 Grand Eagle Centre
 - C26 Harbour Centre
 - C27 China Resources Building
 - C28 Sun Hung Kai Centre
 - C29 Sino Plaza
 - C30 World Trade Centre
 - C31 Excelsior Hotel
 - C32 Excelsior Hotel
 - C33 Windward House
 - C34 19-31 Yue Wo Street
 - C35 Citicorp Centre
 - C36 Citicorp Centre
 - C37 Citicorp Centre
 - C38 Star House
 - C39 Peninsula Hotel
 - C40 Sheraton Hotel
 - C41 Sheraton Hotel
 - C42 New World Centre and Hotel
 - C43 Wing On Plaza
 - C44 Shangri-La Hotel
 - C45 Shangri-La Hotel
 - C46 Empress Centre
 - C47 Empress Centre
 - C48 Grand Stanford Harbour View Hotel
 - C49 Nikko Hotel
 - C50 Four Seasons Hotel
 - C51 Four Seasons Hotel
 - C52 AIA Tower
 - C53 Newton Hotel
 - C54 Electric Centre
 - C55 Shek Yee Estate
 - C56A Shek Yee Estate

- C57 Pacific Place Complex
- C58 Pacific Place Complex
- C59 Pacific Place Complex
- C60 Pacific Place Complex
- C61 Pacific Place Complex
- C62 Pacific Place Complex
- C63 Pacific Place Complex
- C64 Pacific Place Complex
- C65 Pacific Place Complex
- C66 Pacific Place Complex
- C67 Pacific Place Complex
- C68 Pacific Place Complex
- C69 Pacific Place Complex
- C70 Pacific Place Complex
- C71 Pacific Place Complex
- C72 Pacific Place Complex
- C73 Pacific Place Complex
- C74 Pacific Place Complex
- C75 Pacific Place Complex
- C76 Pacific Place Complex
- C77 Pacific Place Complex
- C78 Pacific Place Complex
- C79 Pacific Place Complex
- C80 Pacific Place Complex
- C81 Pacific Place Complex
- C82 Pacific Place Complex
- C83 Pacific Place Complex
- C84 Pacific Place Complex
- C85 Pacific Place Complex
- C86 Pacific Place Complex
- C87 Pacific Place Complex
- C88 Pacific Place Complex
- C89 Pacific Place Complex
- C90 Pacific Place Complex
- C91 Pacific Place Complex
- C92 Pacific Place Complex
- C93 Pacific Place Complex
- C94 Pacific Place Complex
- C95 Pacific Place Complex
- C96 Pacific Place Complex
- C97 Pacific Place Complex
- C98 Pacific Place Complex
- C99 Pacific Place Complex
- C100 Pacific Place Complex

- C101 Pacific Place Complex
- C102 Pacific Place Complex
- C103 Pacific Place Complex
- C104 Pacific Place Complex
- C105 Pacific Place Complex
- C106 Pacific Place Complex
- C107 Pacific Place Complex
- C108 Pacific Place Complex
- C109 Pacific Place Complex
- C110 Pacific Place Complex
- C111 Pacific Place Complex
- C112 Pacific Place Complex
- C113 Pacific Place Complex
- C114 Pacific Place Complex
- C115 Pacific Place Complex
- C116 Pacific Place Complex
- C117 Pacific Place Complex
- C118 Pacific Place Complex
- C119 Pacific Place Complex
- C120 Pacific Place Complex
- C121 Pacific Place Complex
- C122 Pacific Place Complex
- C123 Pacific Place Complex
- C124 Pacific Place Complex
- C125 Pacific Place Complex
- C126 Pacific Place Complex
- C127 Pacific Place Complex
- C128 Pacific Place Complex
- C129 Pacific Place Complex
- C130 Pacific Place Complex
- C131 Pacific Place Complex
- C132 Pacific Place Complex
- C133 Pacific Place Complex
- C134 Pacific Place Complex
- C135 Pacific Place Complex
- C136 Pacific Place Complex
- C137 Pacific Place Complex
- C138 Pacific Place Complex
- C139 Pacific Place Complex
- C140 Pacific Place Complex
- C141 Pacific Place Complex
- C142 Pacific Place Complex
- C143 Pacific Place Complex
- C144 Pacific Place Complex
- C145 Pacific Place Complex
- C146 Pacific Place Complex
- C147 Pacific Place Complex
- C148 Pacific Place Complex
- C149 Pacific Place Complex
- C150 Pacific Place Complex

- GIC1 General Post Office
- GIC2 Old Hall
- GIC3 FLA Residences at Tenor
- GIC4 Police Force Headquarters, May House
- GIC5 Roman Tower
- GIC6 Wan Chai Tower
- GIC7 Police Centre Club
- GIC8 Hong Fa Street Post Office
- GIC9 Victoria Park School for the Deaf
- GIC10 Electric Road Municipal Services Building
- GIC11 Electric Road Municipal Services Building
- GIC12 Electric Road Municipal Services Building
- GIC13 Electric Road Municipal Services Building
- GIC14 Electric Road Municipal Services Building
- GIC15 Electric Road Municipal Services Building
- GIC16 Electric Road Municipal Services Building
- GIC17 Electric Road Municipal Services Building
- GIC18 Electric Road Municipal Services Building
- GIC19 Electric Road Municipal Services Building
- GIC20 Electric Road Municipal Services Building
- GIC21 Electric Road Municipal Services Building
- GIC22 Electric Road Municipal Services Building
- GIC23 Electric Road Municipal Services Building
- GIC24 Electric Road Municipal Services Building
- GIC25 Electric Road Municipal Services Building
- GIC26 Electric Road Municipal Services Building
- GIC27 Electric Road Municipal Services Building
- GIC28 Electric Road Municipal Services Building
- GIC29 Electric Road Municipal Services Building
- GIC30 Electric Road Municipal Services Building
- GIC31 Electric Road Municipal Services Building
- GIC32 Electric Road Municipal Services Building
- GIC33 Electric Road Municipal Services Building
- GIC34 Electric Road Municipal Services Building
- GIC35 Electric Road Municipal Services Building
- GIC36 Electric Road Municipal Services Building
- GIC37 Electric Road Municipal Services Building
- GIC38 Electric Road Municipal Services Building
- GIC39 Electric Road Municipal Services Building
- GIC40 Electric Road Municipal Services Building
- GIC41 Electric Road Municipal Services Building
- GIC42 Electric Road Municipal Services Building
- GIC43 Electric Road Municipal Services Building
- GIC44 Electric Road Municipal Services Building
- GIC45 Electric Road Municipal Services Building
- GIC46 Electric Road Municipal Services Building
- GIC47 Electric Road Municipal Services Building
- GIC48 Electric Road Municipal Services Building
- GIC49 Electric Road Municipal Services Building
- GIC50 Electric Road Municipal Services Building
- GIC51 Electric Road Municipal Services Building
- GIC52 Electric Road Municipal Services Building
- GIC53 Electric Road Municipal Services Building
- GIC54 Electric Road Municipal Services Building
- GIC55 Electric Road Municipal Services Building
- GIC56 Electric Road Municipal Services Building
- GIC57 Electric Road Municipal Services Building
- GIC58 Electric Road Municipal Services Building
- GIC59 Electric Road Municipal Services Building
- GIC60 Electric Road Municipal Services Building

- R1 Residential Properties fronting Tung Lo Wan Road
- R2 Residential Properties fronting Tung Lo Wan Road
- R3 Residential Properties fronting Tung Lo Wan Road
- R4 Residential Properties fronting Tung Lo Wan Road
- R5 Residential Properties fronting Tung Lo Wan Road
- R6 Residential Properties fronting Tung Lo Wan Road
- R7 Residential Properties fronting Tung Lo Wan Road
- R8 Residential Properties fronting Tung Lo Wan Road
- R9 Residential Properties fronting Tung Lo Wan Road
- R10 Residential Properties fronting Tung Lo Wan Road
- R11 Residential Properties fronting Tung Lo Wan Road
- R12 Residential Properties fronting Tung Lo Wan Road
- R13 Residential Properties fronting Tung Lo Wan Road
- R14 Residential Properties fronting Tung Lo Wan Road
- R15 Residential Properties fronting Tung Lo Wan Road
- R16 Residential Properties fronting Tung Lo Wan Road
- R17 Residential Properties fronting Tung Lo Wan Road
- R18 Residential Properties fronting Tung Lo Wan Road
- R19 Residential Properties fronting Tung Lo Wan Road
- R20 Residential Properties fronting Tung Lo Wan Road
- R21 Residential Properties fronting Tung Lo Wan Road
- R22 Residential Properties fronting Tung Lo Wan Road
- R23 Residential Properties fronting Tung Lo Wan Road
- R24 Residential Properties fronting Tung Lo Wan Road
- R25 Residential Properties fronting Tung Lo Wan Road
- R26 Residential Properties fronting Tung Lo Wan Road
- R27 Residential Properties fronting Tung Lo Wan Road
- R28 Residential Properties fronting Tung Lo Wan Road
- R29 Residential Properties fronting Tung Lo Wan Road
- R30 Residential Properties fronting Tung Lo Wan Road
- R31 Residential Properties fronting Tung Lo Wan Road
- R32 Residential Properties fronting Tung Lo Wan Road
- R33 Residential Properties fronting Tung Lo Wan Road
- R34 Residential Properties fronting Tung Lo Wan Road
- R35 Residential Properties fronting Tung Lo Wan Road
- R36 Residential Properties fronting Tung Lo Wan Road
- R37 Residential Properties fronting Tung Lo Wan Road
- R38 Residential Properties fronting Tung Lo Wan Road
- R39 Residential Properties fronting Tung Lo Wan Road
- R40 Residential Properties fronting Tung Lo Wan Road
- R41 Residential Properties fronting Tung Lo Wan Road
- R42 Residential Properties fronting Tung Lo Wan Road
- R43 Residential Properties fronting Tung Lo Wan Road
- R44 Residential Properties fronting Tung Lo Wan Road
- R45 Residential Properties fronting Tung Lo Wan Road
- R46 Residential Properties fronting Tung Lo Wan Road
- R47 Residential Properties fronting Tung Lo Wan Road
- R48 Residential Properties fronting Tung Lo Wan Road
- R49 Residential Properties fronting Tung Lo Wan Road
- R50 Residential Properties fronting Tung Lo Wan Road

- R51 Residential Properties fronting Tung Lo Wan Road
- R52 Residential Properties fronting Tung Lo Wan Road
- R53 Residential Properties fronting Tung Lo Wan Road
- R54 Residential Properties fronting Tung Lo Wan Road
- R55 Residential Properties fronting Tung Lo Wan Road
- R56 Residential Properties fronting Tung Lo Wan Road
- R57 Residential Properties fronting Tung Lo Wan Road
- R58 Residential Properties fronting Tung Lo Wan Road
- R59 Residential Properties fronting Tung Lo Wan Road
- R60 Residential Properties fronting Tung Lo Wan Road
- R61 Residential Properties fronting Tung Lo Wan Road
- R62 Residential Properties fronting Tung Lo Wan Road
- R63 Residential Properties fronting Tung Lo Wan Road
- R64 Residential Properties fronting Tung Lo Wan Road
- R65 Residential Properties fronting Tung Lo Wan Road
- R66 Residential Properties fronting Tung Lo Wan Road
- R67 Residential Properties fronting Tung Lo Wan Road
- R68 Residential Properties fronting Tung Lo Wan Road
- R69 Residential Properties fronting Tung Lo Wan Road
- R70 Residential Properties fronting Tung Lo Wan Road
- R71 Residential Properties fronting Tung Lo Wan Road
- R72 Residential Properties fronting Tung Lo Wan Road
- R73 Residential Properties fronting Tung Lo Wan Road
- R74 Residential Properties fronting Tung Lo Wan Road
- R75 Residential Properties fronting Tung Lo Wan Road
- R76 Residential Properties fronting Tung Lo Wan Road
- R77 Residential Properties fronting Tung Lo Wan Road
- R78 Residential Properties fronting Tung Lo Wan Road
- R79 Residential Properties fronting Tung Lo Wan Road
- R80 Residential Properties fronting Tung Lo Wan Road
- R81 Residential Properties fronting Tung Lo Wan Road
- R82 Residential Properties fronting Tung Lo Wan Road
- R83 Residential Properties fronting Tung Lo Wan Road
- R84 Residential Properties fronting Tung Lo Wan Road
- R85 Residential Properties fronting Tung Lo Wan Road
- R86 Residential Properties fronting Tung Lo Wan Road
- R87 Residential Properties fronting Tung Lo Wan Road
- R88 Residential Properties fronting Tung Lo Wan Road
- R89 Residential Properties fronting Tung Lo Wan Road
- R90 Residential Properties fronting Tung Lo Wan Road
- R91 Residential Properties fronting Tung Lo Wan Road
- R92 Residential Properties fronting Tung Lo Wan Road
- R93 Residential Properties fronting Tung Lo Wan Road
- R94 Residential Properties fronting Tung Lo Wan Road
- R95 Residential Properties fronting Tung Lo Wan Road
- R96 Residential Properties fronting Tung Lo Wan Road
- R97 Residential Properties fronting Tung Lo Wan Road
- R98 Residential Properties fronting Tung Lo Wan Road
- R99 Residential Properties fronting Tung Lo Wan Road
- R100 Residential Properties fronting Tung Lo Wan Road

LEGEND

- PLANNING AND ENGINEERING REVIEW
- STUDY AREA BOUNDARY
- LIMIT OF PRIMARY ZONE OF VISUAL INFLUENCE
- BOUNDARY OF KEY VSRs
- PHOTO TAKING POINT WITH PHOTO NO.
- COMMERCIAL
- COMMERCIAL / RESIDENTIAL
- RESIDENTIAL
- RECREATIONAL
- GOVERNMENT / INSTITUTION / COMMUNITY
- TRANSPORT
- CENTRAL-WANCHAI BYPASS (CWB) INCLUDING ITS ROAD TUNNEL AND SLIP ROADS
- ROAD P2 AND OTHER ROADS WHICH ARE CLASSIFIED AS PRIMARY/DISTRICT DISTRIBUTOR ROADS
- RECLAMATION WORKS INCLUDING ASSOCIATED DREDGING WORKS

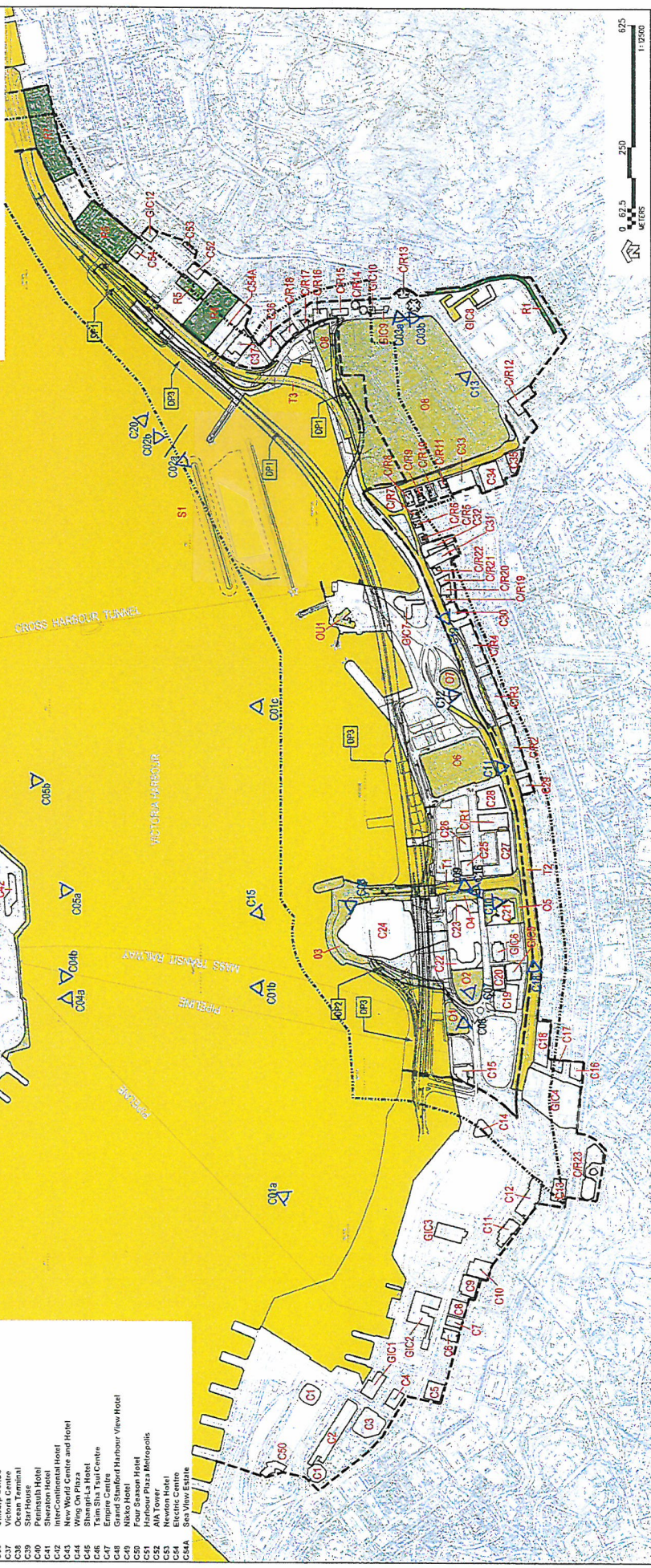

KEY FOR VSRs

- | | | | | |
|--|---|--|---|--|
| C1 International Finance Centre | C/R1 Causeway Centre | GIC8 Queen's College | OU1 Royal Hong Kong Yacht Club | S1 Harbour Traffic |
| C2 Hong Kong Station Development Phase 2 | C/R2 160-169 Gloucester Road | GIC9 Hing Fat Street Post Office | OU2 Planned Waterfront Related Commercial and Leisure Uses (CDE4) | T1 Wanchai North Road Network - vehicular - pedestrian |
| C3 Exchange Square | C/R3 210-226 Gloucester Road | GIC10 Victoria Park School for the Deaf | OU3 Planned Waterfront Related Commercial and Leisure Uses (CDE9) | T2 Gloucester Road Corridor - vehicular - pedestrian |
| C4 Jardine House | C/R4 Elizabeth House | GIC11 YMCA | OU4 Planned Waterfront Related Commercial and Leisure Use (East - WDI/13, WDI/14, WDI/17) | T3 Island Eastern Corridor |
| C5 Mandarin Hotel | C/R5 Riviera Mansion | GIC12 Electric Road Municipal Services Building | R1 Residential Properties fronting Tung Lo Wan Road | |
| C6 Hong Kong Club | C/R6 Prospect Mansion | GIC13 Railway Station WDI/15, Harbour Road Sports Centre and Wan Chai Swimming Pool re-provisioned above the railway station | R4 Harbour Heights | |
| C7 Ritz Carlton Hotel | C/R7 Miami Mansion | GIC14 Planned Hong Kong Academy of Performing Arts | R5 Residential Properties fronting King Wah Road | |
| C8 AIA Tower | C/R8 Marco Polo Mansion | GIC15 Planned Central Government Complex (CDE8) | R6 City Garden | |
| C9 Hutchison House | C/R9 Victoria Park Mansion | GIC16 Planned Government Complex (CDE10) | R7 Provident Garden | |
| C10 Bank of America Tower | C/R10 Chesterfield Mansion | GIC17 Planned CDA Development (CDE3) | | |
| C11 Far East Financial Centre | C/R11 Greenfield Mansion | O2 HKCEC Open Space | | |
| C12 Admiralty Centre | C/R12 Properties fronting Causeway Road | O3 HKCEC Extension Open Space and Promenade | | |
| C13 United Centre | C/R13 Park Towers | O4 Renaissance Harbour View Plaza | | |
| C14 CITIC Tower | C/R14 Viking Garden | O5 Central Plaza Open Space | | |
| C15 Fleet Arcade | C/R15 50-52 Hing Fat Street | O6 Wanchai Sports Ground | | |
| C16 Asian House | C/R16 Mayson Garden Building | O7 Tunnel Approach Rest Garden | | |
| C17 Chung Nam Building | C/R17 Garden House | O8 Victoria Park | | |
| C18 Fleet House, Harcourt House | C/R18 Belle House | O9 Tsim Sha Tsui Waterfront Promenade | | |
| C19 Telecom House, Hong Kong Arts Centre, Harbour View International House | C/R19 Top Glory Tower | O11 Planned Street Market with Outdoor Performance Area | | |
| C20 Shui On Centre | C/R20 Hol Kung Court | O12 Planned Waterfront Regional Open Space | | |
| C21 Central Plaza | C/R21 Hoi To Court | O13 Planned Kiosks and Leisure Boat Landing Area | | |
| C22 Grand Hyatt Hotel | C/R22 Hoi Deen Court | O14 Planned Water Sports Centre | | |
| C23 Renaissance Harbour View Hotel | C/R23 Pacific Place Complex | O15 Planned Boardwalk | | |
| C24 Hong Kong Convention and Exhibition Centre | C/R24 Planned CDA at North Point | O16 Planned Harbour Education Centre | | |
| C25 Great Eagle Centre | C/R25 Planned CDA(1) at North Point | O17 Planned Local Open Space | | |
| C26 Harbour Centre | GIC2 City Hall | O18 Planned Waterfront Park | | |
| C27 China Resources Building | GIC3 PLA Headquarters at Tamar | O19 Planned Regional Open Space (CDE2) | | |
| C28 Sun Hung Kai Centre | GIC4 Hong Kong Police Force Headquarters, May House | | | |
| C29 AXA Centre | GIC5 Revenue Tower | | | |
| C30 Sino Plaza | GIC6 Wan Chai Tower | | | |
| C31 World Trade Centre | GIC7 Police Officers' Club | | | |
| C32 Excelsior Hotel | | | | |
| C33 The Park Lane Hotel | | | | |
| C34 Windsor House | | | | |
| C35 19-31 Yee Wo Street | | | | |
| C36 Citicorp Centre | | | | |
| C37 Victoria Centre | | | | |
| C38 Ocean Terminal | | | | |
| C39 Star House | | | | |
| C40 Peninsula Hotel | | | | |
| C41 Sheraton Hotel | | | | |
| C42 InterContinental Hotel | | | | |
| C43 New World Centre and Hotel | | | | |
| C44 Wing On Plaza | | | | |
| C45 Shangri-La Hotel | | | | |
| C46 Tsim Sha Tsui Centre | | | | |
| C47 Empire Centre | | | | |
| C48 Grand Stanford Harbour View Hotel | | | | |
| C49 Nikko Hotel | | | | |
| C50 Four Season Hotel | | | | |
| C51 Harbour Plaza Metropolis | | | | |
| C52 AIA Tower | | | | |
| C53 Newton Hotel | | | | |
| C54 Electric Centre | | | | |
| C54A Sea View Estate | | | | |
| C55 Planned Trunk Road Administration Building (Beneath Island Eastern Corridor) | | | | |

- LEGEND**
- PLANNING AND ENGINEERING REVIEW STUDY AREA BOUNDARY
 - - - LIMIT OF PRIMARY ZONE OF VISUAL INFLUENCE
 - C1 BOUNDARY OF KEY VSRs
 - COMMERCIAL
 - COMMERCIAL / RESIDENTIAL
 - RESIDENTIAL
 - RECREATIONAL
 - GOVERNMENT / INSTITUTION / COMMUNITY
 - TRANSPORT
 - DP1 CENTRAL-WANCHAI BYPASS (CWB) INCLUDING ITS ROAD TUNNEL AND SLIP ROADS
 - DP2 ROAD P2 AND OTHER ROADS WHICH ARE CLASSIFIED AS PRIMARY/DISTRICT DISTRIBUTOR ROADS
 - DP3 RECLAMATION WORKS INCLUDING ASSOCIATED DREDGING WORKS

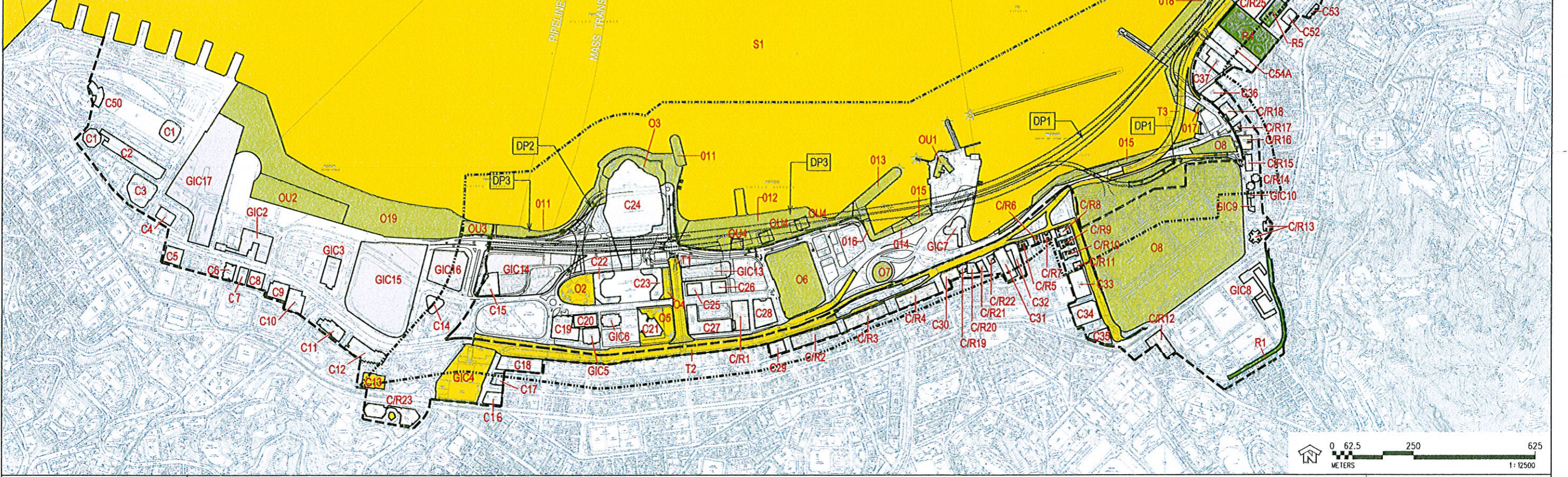

27/9/2007 10:03:44
FILE : ...wanchai\dgn\em\FIGURE 8-3a.dgn

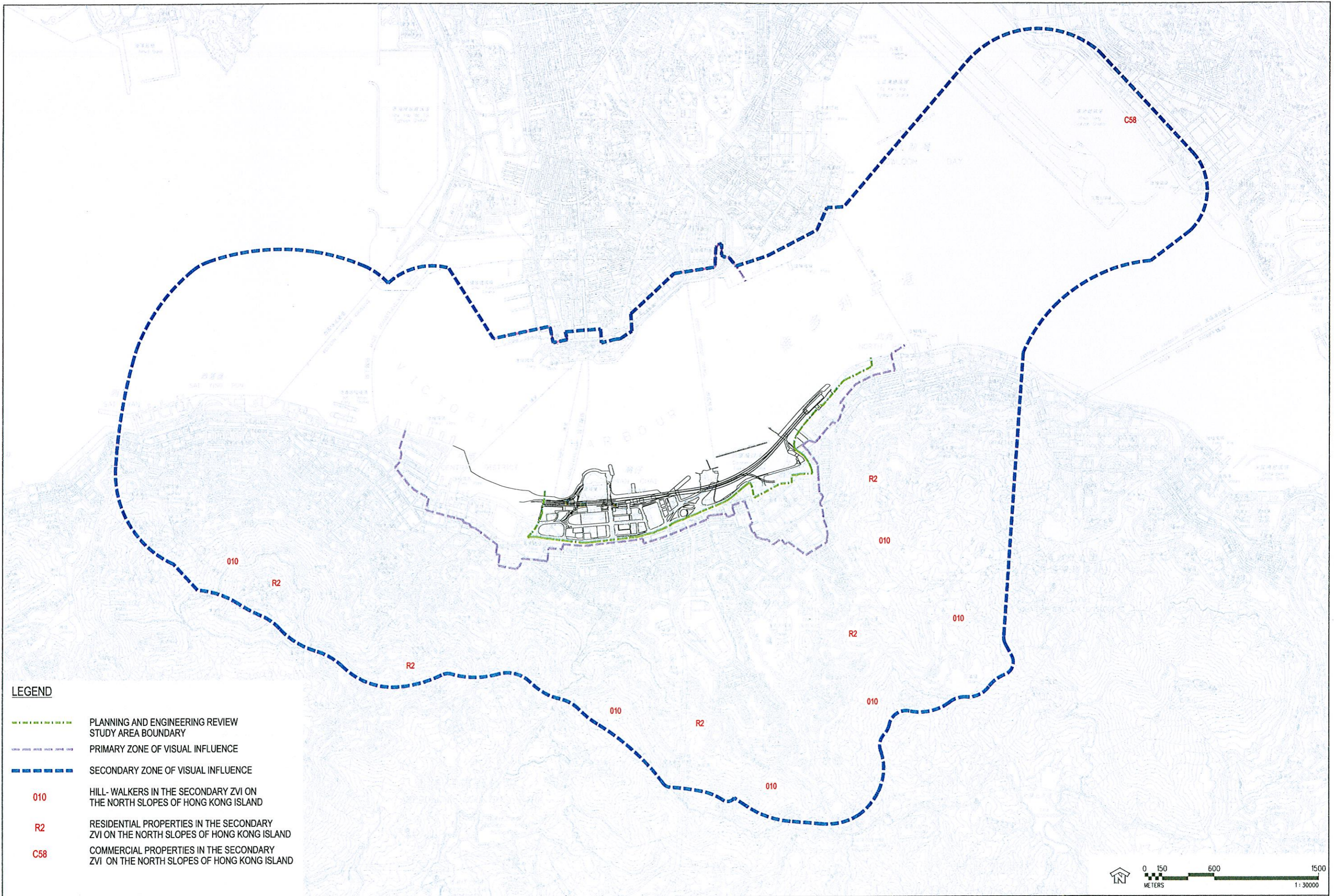

LEGEND

- - - - - PLANNING AND ENGINEERING REVIEW STUDY AREA BOUNDARY
- - - - - PRIMARY ZONE OF VISUAL INFLUENCE
- - - - - SECONDARY ZONE OF VISUAL INFLUENCE
- 010 HILL- WALKERS IN THE SECONDARY ZVI ON THE NORTH SLOPES OF HONG KONG ISLAND
- R2 RESIDENTIAL PROPERTIES IN THE SECONDARY ZVI ON THE NORTH SLOPES OF HONG KONG ISLAND
- C58 COMMERCIAL PROPERTIES IN THE SECONDARY ZVI ON THE NORTH SLOPES OF HONG KONG ISLAND

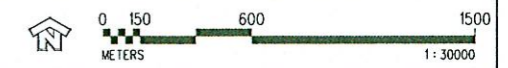

FILE : ...\\wanchai\dgn\em\FIGURE 8-3b.dgn

Appendix A

Implementation Schedule

Appendix A**Table A13.1 Implementation Schedule for Air Quality Control****Table A13.2 Implementation Schedule for Noise Control****Table A13.3 Implementation Schedule for Water Quality Control****Table A13.4 Implementation Schedule for Waste Management****Table A13.6 Implementation Schedule for Marine Ecology****Table A13.7 Implementation Schedule for Landscape and Visual**

Appendix A

Table A13.1 Implementation Schedule for Air Quality Control

EIA Ref	Environmental Protection Measures / Mitigation Measures	Location / Timing	Implementation Agent	Implementation Stages*				Relevant Legislation and Guidelines
				Des	C	O	Dec	
Construction Phase								
<i>For the Whole Project</i>								
S3.6.5	Four times a day watering of the work site with active operations.	Work site / during construction	Contractor		√			EIAO-TM
S3.8.1	<p>Implementation of dust suppression measures stipulated in Air Pollution Control (Construction Dust) Regulation. The following mitigation measures, good site practices and a comprehensive dust monitoring and audit programme are recommended to minimise cumulative dust impacts.</p> <ul style="list-style-type: none"> • Strictly limit the truck speed on site to below 10 km per hour and water spraying to keep the haul roads in wet condition; • Watering during excavation and material handling; • Provision of vehicle wheel and body washing facilities at the exit points of the site, combined with cleaning of public roads where necessary; and • Tarpaulin covering of all dusty vehicle loads transported to, from and between site locations. 	Work site / during construction	Contractor		√			

EIA Ref	Environmental Protection Measures / Mitigation Measures	Location / Timing	Implementation Agent	Implementation Stages*				Relevant Legislation and Guidelines
				Des	C	O	Dec	
S3.5.6	For the dredging activities carried out in the vicinity of Police Officers' Club, the dredging operation will be restricted to only 1 small close grab dredger to minimise the odour impact during the dredging activity. The dredging rate should be reduced as much as practicable for the area in close proximity to the Police Officers' Club. The sediments contain highly contaminated mud which may be disposed with the use of geosynthetic containers (details shall refer to Section 6), grab dredger has to be used for filling up the geosynthetic containers on barges. the dredging rate for the removal of the sediments at the south-west corner of the typhoon shelter shall be slowed down or restricted to specific non-popular hours in weekdays when it is necessary during construction. Carry out odour patrol during dredging in the construction phase.	Corner of CBTS/implementation of harbour-front enhancement	CEDD ¹		√			EIAO-TM
S3.8.8	Carry out dredging at the corner of CBTS to remove the sediment and clean the slime attached on the CBTS shoreline seawall. Carry out odour patrol during dredging in the construction phase.	Corner of CBTS & CBTS shoreline seawall/implementation of harbour-front enhancement	CEDD ²		√			EIAO-TM
Operation Phase								
<i>For the Whole Project</i>								

¹ CEDD will identify an implementation agent.

² CEDD will identify an implementation agent.

EIA Ref	Environmental Protection Measures / Mitigation Measures	Location / Timing	Implementation Agent	Implementation Stages*				Relevant Legislation and Guidelines
				Des	C	O	Dec	
S3.10.2	Monthly (from July to September) monitoring of odour impacts, for a period of 5 years, is proposed during the operational phase of the Project to ascertain the effectiveness of the Enhancement Package over time, and to monitor any on-going odour impacts at the ASRs.	Planned ASRs (CBTS Breakwater)/First 5-year period of operation phase	CEDD ¹			√		EIAO-TM

- Des - Design, C - Construction, O – Operation, and Dec – Decommissioning

Table A13.2 Implementation Schedule for Noise Control

EIA Ref	Environmental Protection Measures / Mitigation Measures	Location / Timing	Implementation Agent	Implementation Stages*				Relevant Legislation and Guidelines
				Des	C	O	Dec	
Construction Phase								
<i>For the Whole Project</i>								
S4.9.4	Good Site Practice: <ul style="list-style-type: none"> • Only well-maintained plant shall be operated on-site and plant shall be serviced regularly during the construction program. • Silencers or mufflers on construction equipment shall be utilized and shall be properly maintained during the construction program. • Mobile plant, if any, shall be sited as far away from NSRs as possible. • Machines and plant (such as trucks) that may be in intermittent use shall be shut down between works periods or shall be throttled down to a minimum. • Plant known to emit noise strongly in one direction shall, wherever possible, be orientated so that the noise is directed away from the nearby NSRs. • Material stockpiles and other structures shall be effectively utilized, wherever practicable, in screening noise from on-site construction activities. 	Work Sites / During Construction	Contractor		√			EIAO-TM, NCO

EIA Ref	Environmental Protection Measures / Mitigation Measures	Location / Timing	Implementation Agent	Implementation Stages*				Relevant Legislation and Guidelines
				Des	C	O	Dec	
<i>For DP3 – Reclamation Works</i>								
S4.8.3 – S4.8.4	Use of quiet powered mechanical equipment for the following task: <ul style="list-style-type: none"> Filling behind seawall Seawall construction 	Work Sites / During Construction	Contractor		√			EIAO-TM, NCO
<i>For DP5 – Wan Chai East Sewage Outfall</i>								
S4.8.3 – S4.8.4	Use of quiet powered mechanical equipment for the following tasks: <ul style="list-style-type: none"> Submarine pipelines (marine section) Use of quiet powered mechanical equipment and movable noise barrier for the following tasks: <ul style="list-style-type: none"> Installation of a new pipeline (land section) 	Work Sites / During Construction	Contractor		√			EIAO-TM, NCO
<i>For DP6 – Cross-Harbour Water Mains from Wan Chai to Tsim Sha Tsui</i>								
S4.8.3 – S4.8.4	Use of quiet powered mechanical equipment for the following tasks: <ul style="list-style-type: none"> Submarine pipelines (marine section) 	Work Sites / During Construction	Contractor		√			EIAO-TM, NCO

* Des - Design, C - Construction, O – Operation, and Dec - Decommissioning

Table A13.3 Implementation Schedule for Water Quality Control

EIA Ref	Environmental Protection Measures / Mitigation Measures	Location / Timing	Implementation Agent	Implementation Stages*				Relevant Legislation and Guidelines
				Des	C	O	Dec	
Construction Phase								
<i>For DP3 – Reclamation Works, DP5 (Wan Chai East Sewage Outfall), DP6 (Cross-Harbour Water Mains from Wan Chai to Tsim Sha Tsui)</i>								
S5.8	A phased reclamation approach is planned for the WDII. Containment of fill within each of the reclamation phases by seawalls is proposed, with the seawall constructed first (above high water mark) with filling carried out behind the completed seawalls. Any gaps that may need to be provided for marine access will be shielded by silt curtains to control sediment plume dispersion away from the site. Filling for seawall construction should be carried out behind the silt curtain	Work site / During the construction period	Contractor		√			EIAO-TM, WPCO
S5.8	Dredging shall be carried out by closed grab dredger for the following works: <ul style="list-style-type: none"> • Seawall construction in all the reclamation areas; • Construction of the CWB Tunnel • Construction of the proposed WSD water mains; and • Construction of the proposed Wan Chai East sewage outfall pipelines. 	Work site / During the construction period	Contractor		√			EIAO-TM, WPCO
S5.8, Figure 5.3	Dredging for the Wan Chai East sewage outfall pipelines shall not be carried out concurrently with the following activities: <ul style="list-style-type: none"> • Dredging along the proposed cross-harbour water mains; • Dredging along the seawall in the Wan Chai Reclamation (WCR) zone (area between HKCEC Extension and PCWA). 	Work site / During the construction period	Contractor		√			EIAO-TM, WPCO
S5.8	The water body behind the temporary reclamations within the Causeway Bay typhoon shelter shall not be fully enclosed.	Work site / During the construction period	Contractor		√			EIAO-TM, WPCO

EIA Ref	Environmental Protection Measures / Mitigation Measures	Location / Timing	Implementation Agent	Implementation Stages*				Relevant Legislation and Guidelines																																													
				Des	C	O	Dec																																														
S5.8	As a mitigation measure, to avoid the accumulation of water borne pollutants within the temporary embayment between CR11 and HKCEC1, an impermeable barrier, suspended from a floating boom on the water surface and extending down to the seabed, will be erected by the contractor before the HKCEC1 commences. The barrier will channel the stormwater discharge flows from Culvert L to the outside of the embayment. The contractor will maintain this barrier until the reclamation works in HKCEC2W are carried out and the new Culvert L extension is constructed.	Work site / During the construction period	Contractor		√			EIAO-TM, WPCO																																													
S5.8, Figure 5.3	<p>The total dredging rates in each of the marine works zones shall not be more than the maximum production rates stated in the table below. These are the production rates without considering the effect of silt curtain.</p> <table border="1"> <thead> <tr> <th rowspan="2">Reclamation Area</th> <th colspan="2">Maximum Dredging Rate</th> <th rowspan="2">Maximum Dredging Rate (m³ per week)</th> </tr> <tr> <th>m³ per day</th> <th>m³ per hour (for 16 hrs per day)</th> </tr> </thead> <tbody> <tr> <td colspan="4">Dredging along seawall or breakwater</td> </tr> <tr> <td>North Point Shoreline Zone (NPR)</td> <td>6,000</td> <td>375</td> <td>42,000</td> </tr> <tr> <td>Causeway Bay Shoreline Zone</td> <td>TBW</td> <td>1,500</td> <td>94</td> </tr> <tr> <td></td> <td>TCBR</td> <td>6,000</td> <td>375</td> </tr> <tr> <td>PCWA Zone</td> <td>5,000</td> <td>313</td> <td>35,000</td> </tr> <tr> <td>Wan Chai Shoreline Zone (WCR)</td> <td>6,000</td> <td>375</td> <td>42,000</td> </tr> <tr> <td>HKCEC Shoreline Zone (HKCEC)</td> <td>HKCEC Stage 1 & 3</td> <td>1,500</td> <td>94</td> </tr> <tr> <td></td> <td>HKCEC Stage 2</td> <td>6,000</td> <td>375</td> </tr> <tr> <td>Cross Harbour Water Mains</td> <td>1,500</td> <td>94</td> <td>10,500</td> </tr> <tr> <td>Wan Chai East Submarine Sewage Pipeline</td> <td>1,500</td> <td>94</td> <td>10,500</td> </tr> </tbody> </table> <p>Note: 1,500 m³ per day shall be applied for construction of the western seawall of WCR1.</p>	Reclamation Area	Maximum Dredging Rate		Maximum Dredging Rate (m ³ per week)	m ³ per day	m ³ per hour (for 16 hrs per day)	Dredging along seawall or breakwater				North Point Shoreline Zone (NPR)	6,000	375	42,000	Causeway Bay Shoreline Zone	TBW	1,500	94		TCBR	6,000	375	PCWA Zone	5,000	313	35,000	Wan Chai Shoreline Zone (WCR)	6,000	375	42,000	HKCEC Shoreline Zone (HKCEC)	HKCEC Stage 1 & 3	1,500	94		HKCEC Stage 2	6,000	375	Cross Harbour Water Mains	1,500	94	10,500	Wan Chai East Submarine Sewage Pipeline	1,500	94	10,500	Work site / During the construction period	Contractor		√		EIAO-TM, WPCO
Reclamation Area	Maximum Dredging Rate		Maximum Dredging Rate (m ³ per week)																																																		
	m ³ per day	m ³ per hour (for 16 hrs per day)																																																			
Dredging along seawall or breakwater																																																					
North Point Shoreline Zone (NPR)	6,000	375	42,000																																																		
Causeway Bay Shoreline Zone	TBW	1,500	94																																																		
	TCBR	6,000	375																																																		
PCWA Zone	5,000	313	35,000																																																		
Wan Chai Shoreline Zone (WCR)	6,000	375	42,000																																																		
HKCEC Shoreline Zone (HKCEC)	HKCEC Stage 1 & 3	1,500	94																																																		
	HKCEC Stage 2	6,000	375																																																		
Cross Harbour Water Mains	1,500	94	10,500																																																		
Wan Chai East Submarine Sewage Pipeline	1,500	94	10,500																																																		
S5.8, Figure 5.3	Dredging along the seawall at WCR1 shall be undertaken initially at 1,500m ³ per day for construction of the western seawall (which is in close proximity of the WSD intake), followed by partial seawall construction at the western seawall (above high water mark) to protect the adjacent intakes as much as possible from further dredging activities.	Work site / During the construction period	Contractor		√			EIAO-TM, WPCO																																													

EIA Ref	Environmental Protection Measures / Mitigation Measures	Location / Timing	Implementation Agent	Implementation Stages*				Relevant Legislation and Guidelines
				Des	C	O	Dec	
S5.8, Figure 5.3	For dredging within the Causeway Bay typhoon shelter, seawall shall be partially constructed to protect the nearby seawater intakes from further dredging activities. For example, at TCBR1W, the southern and eastern seawalls shall be constructed first (above high water mark) so that the seawater intakes at the inner water would be protected from the impacts from the remaining dredging activities along the northern boundary.	Work site / During the construction period	Contractor		√			EIAO-TM, WPCO
S5.8, Figure 5.3	Silt curtains shall be deployed around the closed grab dredgers during seawall dredging and seawall trench filling in the areas of HKCEC, WCR, TCBR and NP.	Work site / During the construction period	Contractor		√			EIAO-TM, WPCO
S5.8, Figure 5.3	Silt screens shall be applied to seawater intakes at interim construction stages as stated below:		Work site / During the construction period	Contractor		√		EIAO-TM, WPCO
	Interim Construction Stage	Location of Applications						
	Scenario 2A in early 2009 with concurrent dredging activities at HKCEC, WCR, TPCWA, TBW, NP and Water Mains Zone	WSD saltwater intakes at Sai Wan Ho, Quarry Bay, Sheung Wan, Wan Chai, Kowloon South Cooling water intakes for Hong Kong Convention and Exhibition Centre Extension, Hong Kong Convention and Exhibition Centre Phase I, Telecom House / HK Academy for Performing Arts / Shun On Centre, Wan Chai Tower / Revenue Tower / Immigration Tower and Sun Hung Kai Centre						
	Scenario 2B in late 2009/2010 with concurrent dredging activities at Sewage Pipelines Zone and TCBR.	WSD saltwater intakes at Sheung Wan, Wan Chai Cooling water intakes for Queensway Government Offices, Excelsior Hotel, World Trade Centre and Windsor House.						
	Scenario 2C in 2011 with concurrent dredging activities at HKCEC and TCBR.	WSD saltwater intakes at Sheung Wan and Re-provisioned WSD Wan Chai saltwater intake. Cooling water intakes for MTR South, Excelsior Hotel & World Trade Centre and re-provisioned Windsor House.						

EIA Ref	Environmental Protection Measures / Mitigation Measures	Location / Timing	Implementation Agent	Implementation Stages*				Relevant Legislation and Guidelines
				Des	C	O	Dec	
S5.8	<p>Other mitigation measures include:</p> <ul style="list-style-type: none"> mechanical grabs, if used, shall be designed and maintained to avoid spillage and sealed tightly while being lifted. For dredging of any contaminated mud, closed watertight grabs must be used; all vessels shall be sized so that adequate clearance is maintained between vessels and the seabed in all tide conditions, to ensure that undue turbidity is not generated by turbulence from vessel movement or propeller wash; all hopper barges and dredgers shall be fitted with tight fitting seals to their bottom openings to prevent leakage of material; construction activities shall not cause foam, oil, grease, scum, litter or other objectionable matter to be present on the water within the site or dumping grounds; loading of barges and hoppers shall be controlled to prevent splashing of dredged material into the surrounding water. Barges or hoppers shall not be filled to a level that will cause the overflow of materials or polluted water during loading or transportation; and before commencement of the reclamation works, the holder of Environmental Permit has to submit plans showing the phased construction of the reclamation, design and operation of the silt curtain. 	Work site / During the construction period	Contractor		√			ProPECC PN 1/94; WPCO (TM-DSS)
S5.8	<p>Silt screens are recommended to be deployed at the seawater intakes during the reclamation works period. Installation of silt screens at the seawater intake points may cause a potential for accumulation and trapping of pollutants, floating debris and refuse behind the silt screens and may lead to potential water quality deterioration at the seawater intake points. Major sources of pollutants and floating refuse include the runoff and storm water discharges from the nearby coastal areas. As a mitigation measure to avoid the pollutant and refuse entrapment problems and to ensure that the impact monitoring results are representative, regular maintenance of the silt screens and refuse collection shall be performed at the monitoring stations at regular</p>	Work site / During the construction period	Contractor		√			EIAO-TM, WPCO

EIA Ref	Environmental Protection Measures / Mitigation Measures	Location / Timing	Implementation Agent	Implementation Stages*				Relevant Legislation and Guidelines
				Des	C	O	Dec	
	intervals on a daily basis. The Contractor shall be responsible for keeping the water behind the silt screen free from floating rubbish and debris during the impact monitoring period.							

EIA Ref	Environmental Protection Measures / Mitigation Measures	Location / Timing	Implementation Agent	Implementation Stages*				Relevant Legislation and Guidelines
				Des	C	O	Dec	
S5.8	Dredging of contaminated mud is recommended as a mitigation measures for control of operational odour impact from the Causeway Bay typhoon shelter. In recognition of the potential impacts caused by dredging activities close to the seawater intakes, only 1 small close grab dredger shall be operated within the typhoon shelter (for the dredging to mitigate odour impact) at any time to minimize the potential impact. Double silt curtains shall be deployed to fully enclose the closed grab dredger during the dredging operation. In addition, an impermeable barrier, suspended from a floating boom on the water surface and extended down to the seabed, shall be erected to isolate the adjacent intakes as much as possible from dredging activities. For example, if dredging is to be carried out at the southwest corner of the typhoon shelter, physical barriers shall be erected to west of the cooling water intake for Excelsior Hotel so that the intake would be shielded from most of the SS generated from the dredging operation to the west of the intake. For area in close proximity of the cooling water intake point, the dredging rate shall be reduced as much as practicable. Site audit and water quality monitoring shall be carried out at the seawater intakes during the dredging operations. Daily monitoring of SS at the cooling water intake shall be carried out, and 24 hour monitoring of turbidity at the intakes shall be implemented during the dredging activities. If the monitoring results indicate that the dredging operation has caused significant changes in water quality conditions at the seawater intakes, appropriate actions shall be taken to stop the dredging and mitigation measures such as slowing down the dredging rate shall be implemented.	Causeway Bay typhoon shelter/Implementation of harbour-front enhancement.	CEDD ³		√			WPCO

³ CEDD will identify an implementation agent.

EIA Ref	Environmental Protection Measures / Mitigation Measures	Location / Timing	Implementation Agent	Implementation Stages*				Relevant Legislation and Guidelines
				Des	C	O	Dec	
<i>For the Whole Project</i>								
S5.8	<ul style="list-style-type: none"> Construction Runoff and Drainage use of sediment traps, wheel washing facilities for vehicles leaving the site, and adequate maintenance of drainage systems to prevent flooding and overflow; Permanent drainage channels shall incorporate sediment basins or traps and baffles to enhance deposition rates. The design of efficient silt removal facilities shall be based on the guidelines in Appendix A1 of ProPECC PN 1/94; a sediment tank constructed from pre-formed individual cells of approximately 6 - 8 m3 capacity can be used for settling ground water prior to disposal; oil interceptors shall be provided in the drainage system for the tunnels and regularly cleaned to prevent the release of oils and grease into the storm water drainage system after accidental spillages. The interceptor shall have a bypass to prevent flushing during periods of heavy rain; precautions and actions to be taken when a rainstorm is imminent or forecast, and during or after rainstorms. Particular attention shall be paid to the control of any silty surface runoff during storm events; on-site drainage system shall be installed prior to the commencement of other construction activities. Sediment traps shall be installed in order to minimise the sediment loading of the effluent prior to discharge; All temporary and permanent drainage pipes and culverts provided to facilitate runoff discharge shall be adequately designed for the controlled release of storm flows. All sediment control measures shall be regularly inspected and maintained to ensure proper and efficient operation at all times and particularly following rain storms. The temporarily diverted drainage shall be reinstated to its original condition when the construction work is finished or the temporary diversion is no longer required. All fuel tanks and store areas shall be provided with locks and be sited 	<ul style="list-style-type: none"> Work site / During the construction period 	Contractor		√			ProPECC PN 1/94; WPCO (TM-DSS)

EIA Ref	Environmental Protection Measures / Mitigation Measures	Location / Timing	Implementation Agent	Implementation Stages*				Relevant Legislation and Guidelines
				Des	C	O	Dec	
	on sealed areas, within bunds of a capacity equal to 110% of the storage capacity.							
	<ul style="list-style-type: none"> Minimum distances of 100 m shall be maintained between the storm water discharges and the existing or planned WSD flushing water intakes during construction phase. 							
S5.8	<p><i>Sewage from Construction Work Force</i></p> <p>Construction work force sewage discharges on site shall be connected to the existing trunk sewer or sewage treatment facilities. The construction sewage shall be handled by portable chemical toilets prior to the commission of the on-site sewer system. Appropriate numbers of portable toilets shall be provided by a licensed contractor to serve the large number of construction workers over the construction site. The Contractor shall also be responsible for waste disposal and maintenance practices.</p>	Work site / During the construction period	Contractor		√			ProPECC PN 1/94; WPCO (TM-DSS)
S5.8	<p><i>Floating Debris and Refuse</i></p> <p>Collection and removal of floating refuse shall be performed at regular intervals on a daily basis. The contractor shall be responsible for keeping the water within the site boundary and the neighbouring water free from rubbish.</p>	Work site and adjacent water / During the construction period.	Contractor		√			WPCO

EIA Ref	Environmental Protection Measures / Mitigation Measures	Location / Timing	Implementation Agent	Implementation Stages*				Relevant Legislation and Guidelines
				Des	C	O	Dec	
S5.8	<p><i>Storm Water Discharges</i></p> <p>Minimum distances of 100 m shall be maintained between the existing or planned stormwater discharges and the existing or planned WSD flushing water intakes.</p>	Work site and adjacent water / During the design and construction period.	Contractor	√	√			WPCO

* Des - Design, C - Construction, O – Operation, and Dec - Decommissioning

Table A13.4 Implementation Schedule for Waste Management

EIA Ref	Environmental Protection Measures / Mitigation Measures	Location / Timing	Implementation Agent	Implementation Stages*				Relevant Legislation and Guidelines
				Des	C	O	Dec	
Construction Phase								
<i>For DP3 – Reclamation Works</i>								
S6.7.2	<p>Marine Sediments</p> <p>The dredged marine sediments would be loaded onto barges, transported to and disposed of at the designated disposal sites at South of Cheung Chau, East of Ninepin, East of Tung Lung Chau, South of Tsing Yi or East of Sha Chau to be allocated by the MFC depending on their level of contamination or at other disposal sites after consultation with the MFC and EPD. In accordance with the ETWB TCW No. 34/2002, the contaminated material must be dredged and transported with great care. The mitigation measures recommended in Section 5 of the EIA Report shall be incorporated. The dredged contaminated sediment must be effectively isolated from the environment upon final disposal and shall be disposed of at the Type 2 confined marine disposal contaminated mud pit.</p>	Work site / During the construction period	Contractor		√			ETWB TCW No. 34/2002

EIA Ref	Environmental Protection Measures / Mitigation Measures	Location / Timing	Implementation Agent	Implementation Stages*				Relevant Legislation and Guidelines
				Des	C	O	Dec	
S6.7.3	Based on the biological screening results, the Category H (>10xLCEL) sediment which failed the biological testing would require Type 3 special disposal. The volume of Category H sediment from the Causeway Bay typhoon shelter which would require special disposal arrangements is estimated to be approximately 0.05 Mm ³ . A feasible containment method is proposed whereby the dredged sediments are sealed in geosynthetic containers and, at the disposal site, the containers would be dropped into the designated contaminated mud pit where they would be covered by further mud disposal and later by the mud pit capping, thereby meeting the requirements for fully confined mud disposal.							
S6.7.5	It will be the responsibility of the Contractor to satisfy the appropriate authorities that the contamination levels of the marine sediment to be dredged have been analysed and recorded. According to the ETWB TCW No. 34/2002, this will involve the submission of a formal Sediment Quality Report to the DEP, at least 3 months prior to the dredging contract being tendered							
S6.7.6	<p>During transportation and disposal of the dredged marine sediments requiring Type 1 and Type 2 disposal, the following measures shall be taken to minimise potential impacts on water quality:</p> <ul style="list-style-type: none"> • Bottom opening of barges shall be fitted with tight fitting seals to prevent leakage of material. Excess material shall be cleaned from the decks and exposed fittings of barges and hopper dredgers before the vessel is moved. 							

EIA Ref	Environmental Protection Measures / Mitigation Measures	Location / Timing	Implementation Agent	Implementation Stages*				Relevant Legislation and Guidelines
				Des	C	O	Dec	
	<ul style="list-style-type: none"> Monitoring of the barge loading shall be conducted to ensure that loss of material does not take place during transportation. Transport barges or vessels shall be equipped with automatic self-monitoring devices as specified by the DEP. Barges or hopper barges shall not be filled to a level that would cause the overflow of materials or sediment laden water during loading or transportation. 							
S6.6.12	<p><i>Floating Refuse</i> During the construction phase, the project proponent's contractor will be responsible for the collection of any refuse within their works area. Floating booms will be provided on the water surface to confine the refuse from the working barges as well as to avoid the accumulation of pollutants within temporary embayment as mentioned in Table 13.3.</p>	Work site / During the construction period	Contractor		√			
<i>For the Whole Project</i>								

EIA Ref	Environmental Protection Measures / Mitigation Measures	Location / Timing	Implementation Agent	Implementation Stages*				Relevant Legislation and Guidelines
				Des	C	O	Dec	
S6.7.7	<p><i>Good Site Practices</i></p> <p>Recommendations for good site practices during the construction activities include:</p> <ul style="list-style-type: none"> • nomination of an approved person, such as a site manager, to be responsible for good site practices, arrangements for collection and effective disposal to an appropriate facility, of all wastes generated at the site; • training of site personnel in proper waste management and chemical waste handling procedures; • provision of sufficient waste disposal points and regular collection for disposal; • appropriate measures to minimise windblown litter and dust during transportation of waste by either covering trucks or by transporting wastes in enclosed containers; • regular cleaning and maintenance programme for drainage systems, sumps and oil interceptors; and • a recording system for the amount of wastes generated, recycled and disposed of (including the disposal sites). 	Work site / During the construction period	Contractor		√			Waste Disposal Ordinance (Cap.354)

EIA Ref	Environmental Protection Measures / Mitigation Measures	Location / Timing	Implementation Agent	Implementation Stages*				Relevant Legislation and Guidelines
				Des	C	O	Dec	
S6.7.8	<p><i>Waste Reduction Measures</i></p> <p>Waste reduction is best achieved at the planning and design stage, as well as by ensuring the implementation of good site practices. Recommendations to achieve waste reduction include:</p> <ul style="list-style-type: none"> • segregation and storage of different types of waste in different containers, skips or stockpiles to enhance reuse or recycling of materials and their proper disposal; • to encourage collection of aluminium cans, PET bottles and paper, separate labelled bins shall be provided to segregate these wastes from other general refuse generated by the work force; • any unused chemicals or those with remaining functional capacity shall be recycled; • use of reusable non-timber formwork, such as in casting the tunnel box sections, to reduce the amount of C&D material. • prior to disposal of C&D waste, it is recommended that wood, steel and other metals shall be separated for re-use and / or recycling to minimise the quantity of waste to be disposed of to landfill; • proper storage and site practices to minimise the potential for damage or contamination of construction materials; and • plan and stock construction materials carefully to minimise amount of waste generated and avoid unnecessary generation of waste. 	Work site / During planning and design stage, and construction stage	Contractor	√	√			

EIA Ref	Environmental Protection Measures / Mitigation Measures	Location / Timing	Implementation Agent	Implementation Stages*				Relevant Legislation and Guidelines
				Des	C	O	Dec	
S6.7.10	<p><i>General Refuse</i></p> <p>General refuse shall be stored in enclosed bins or compaction units separate from C&D material. A licensed waste collector shall be employed by the contractor to remove general refuse from the site, separately from C&D material.</p> <p>A collection area shall be provided where wastes can be stored and loaded prior to removal from site. An enclosed and covered area is recommended to reduce the occurrence of 'wind blow' light material.</p>	Work site / During the construction period	Contractor		√			Public Health and Municipal Services Ordinance (Cap. 132)
S6.7.11	<p><i>Chemical Wastes</i></p> <p>After use, chemical wastes (for example, cleaning fluids, solvents, lubrication oil and fuel) shall be handled according to the Code of Practice on the Packaging, Labelling and Storage of Chemical Wastes. Spent chemicals shall be collected by a licensed collector for disposal at the CWTF or other licensed facility in accordance with the Waste Disposal (Chemical Waste) (General) Regulation.</p>	Work site / During the construction period	Contractor		√			<p>Waste Disposal (Chemical Waste) (General) Regulation</p> <p>Code of Practice on the Packaging, Labelling and Storage of Chemical Wastes</p>
S6.7.12	<p><i>Construction and Demolition Material</i></p> <p>C&D material shall be sorted on-site into inert C&D material (that is, public fill) and C&D waste. All the suitable inert C&D material shall be broken down to 250 mm in size for reuse as public fill in the WDII reclamation. C&D waste, such as wood, glass, plastic, steel and other metals shall be reused or recycled and, as a last resort, disposed of to landfill. A suitable area shall be designated to facilitate the sorting process and a temporary stockpiling area will be required for the separated materials.</p>	Work site / During the construction period	Contractor		√			ETWB TCW No. 33/2002, 31/2004, 19/2005

EIA Ref	Environmental Protection Measures / Mitigation Measures	Location / Timing	Implementation Agent	Implementation Stages*				Relevant Legislation and Guidelines
				Des	C	O	Dec	
S6.7.13	In order to monitor the disposal of public fill and C&D waste at public filling facilities and landfills, respectively, and to control fly tipping, a trip-ticket system shall be included as one of the contractual requirements and implemented by the Environmental Team undertaking the environmental monitoring and audit work. An Independent Environment Checker shall be responsible for auditing the results of the system.	Work site / During the construction period	Contractor and Independent Environmental Checker		√			ETWB TCW No. 31/2004
S6.7.14	<p><i>Bentonite Slurry</i></p> <p>The disposal of residual used bentonite slurry shall follow the good practice guidelines stated in ProPECC PN 1/94 "Construction Site Drainage" and listed as follows:</p> <ul style="list-style-type: none"> • If the disposal of a certain residual quantity cannot be avoided, the used slurry may be disposed of at the marine spoil grounds subject to obtaining a marine dumping licence from EPD on a case-by-case basis. • If the used bentonite slurry is intended to be disposed of through the public drainage system, it shall be treated to the respective effluent standards applicable to foul sewers, storm drains or the receiving waters as set out in the Technical Memorandum of Standards for Effluents Discharged into Drainage and Sewerage Systems, Inland and Coastal Waters. • If the used bentonite slurry is intended to be disposed to public fill reception facilities, it will be mixed with dry soil on site before disposal. 	Work site / During the construction period	Contractor		√			ProPECC PN 1/94

* Des - Design, C - Construction, O - Operation, and Dec - Decommissioning

Table A13.6 Implementation Schedule for Marine Ecology

EIA Ref	Environmental Protection Measures / Mitigation Measures	Location / Timing	Implementation Agent	Implementation Stages*				Relevant Legislation and Guidelines
				Des	C	O	Dec	
Construction Phase								
<i>For the Whole Project - Schedule 3 DP</i>								
S.9.7.2	Alternative design of the Trunk Road constructed in tunnel shall be adopted to avoid permanent reclamation in CBTS and ex-PWCA Basin.	-	CEDD/HyD	√				EIAO TM Annex 16 (Section 8.4) & EIAO Guidance Note No. 3/2002.
<i>For DP3 – Reclamation Works</i>								
S.9.7.3	Translocation of those potentially affected coral colonies to the nearby suitable habitats such as Junk Bay is recommended. A detailed translocation plan (including translocation methodology, monitoring of transplanted corals, etc.) should be drafted and approval by AFCD during the detailed design stage of the Project.	Ex-PCWA Basin and along seawall next to a public pier which is about 250 m away from the CBTS	CEDD/HyD	√				EIAO TM Annex 16 (Section 8.4) & EIAO Guidance Note No. 3/2002.
S.9.7.4	During dredging and filling operations, a number of mitigation measures to control water quality shall be adopted to confine sediment plume within reclamation area and protect marine fauna in proximity to the reclamation. The mitigation measures include the following: <ul style="list-style-type: none"> • Installation of silt curtains during dredging activities • Use of tightly-closed grab dredger • Reduction of dredging rate • Control of grab descending speed • Construction of leading edges of seawall in the early stages of the reclamation works 	Work site / during construction phase	Contractor		√			EIAO TM Annex 16 (Section 8.4) & EIAO Guidance Note No. 3/2002.
	• Adoption of multiple-phase construction schedule							

EIA Ref	Environmental Protection Measures / Mitigation Measures	Location / Timing	Implementation Agent	Implementation Stages*				Relevant Legislation and Guidelines
				Des	C	O	Dec	
S.9.7.6	<p>To minimize potential disturbance impacts on the foraging ardeid population in the CBTS, particularly in the area near the A King Shipyard, appropriate mitigation measures shall be adopted particularly during the construction phase. The following measures are recommended:</p> <ul style="list-style-type: none"> • Use of Quiet Mechanical Plant during the construction phase shall be adopted wherever possible. • Adoption of multiple-phase construction schedule. • General measures to reduce noise generated during the construction phase (see noise impact assessment) shall be effectively implemented. 	Work site / during construction phase	Contractor		√			EIAO TM Annex 16 (Section 8.4) & EIAO Guidance Note No. 3/2002.
S.9.7.7	Seawalls shall be constructed in advance around the reclamation areas within the area of the CBTS to screen adjacent feeding ground from construction phase activities, reduce noise disturbance to the associated seabirds and also to restrict access to this habitat adjacent to works areas by ship traffic.	Work site / during construction phase	Contractor		√			EIAO TM Annex 16 (Section 8.4) & EIAO Guidance Note No. 3/2002.
S.9.7.8	Loss of artificial seawall habitats shall be reinstated by the construction of about 1 km vertical wave absorbing seawall along the coastlines of the new reclamation around the HKCEC and at North Point. The new seawalls are expected to provide large area of hard substrata for settlement and recruitment of intertidal fauna similar to those previously recorded from existing intertidal habitats.	Work site / during construction phase	Contractor		√			EIAO TM Annex 16 (Section 8.4) & EIAO Guidance Note No. 3/2002.

*Des - Design, C - Construction, O – Operation, and Dec - Decommissioning

Table A13.7 Implementation Schedule for Landscape and Visual

EIA Ref	Environmental Protection Measures / Mitigation Measures	Location / Timing	Implementation Agent	Implementation Stages*				Relevant Legislation and Guidelines
				Des	C	O	Dec	
Construction Phase								
For the Whole Project								
Table 10.5	CM1 Topsoil, where identified, shall be stripped and stored for re-use in the construction of the soft landscape works, where practical.	Work site / During Construction Phase	Contractor	√	√			EIAO TM
Table 10.5	CM2 Existing trees to be retained on site shall be carefully protected during construction.	Work site / During Construction Phase	Contractor	√	√			EIAO TM
Table 10.5	CM3 Trees unavoidably affected by the works shall be transplanted where practical.	Work site / During Construction Phase	Contractor	√	√			EIAO TM
Table 10.5	CM4 Compensatory tree planting shall be provided to compensate for felled trees.	Work site / During Construction Phase	Contractor	√	√			EIAO TM
Table 10.5	CM5 Control of night-time lighting.	Work site / During Construction Phase	Contractor		√			EIAO TM
Table 10.5	CM6 Erection of decorative screen hoarding compatible with the surrounding setting.	Work site / During Construction Phase	Contractor		√			EIAO TM
For DP3 – Reclamation Works								
Table 10.5	CM5 Control of night-time lighting.	Work site / During Construction Phase	Contractor		√			EIAO TM
Table 10.5	CM6 Erection of decorative screen hoarding compatible with the surrounding setting.	Work site / During Construction Phase	Contractor		√			EIAO TM
For DP5 – Wan Chai East Sewage Outfall								
Refer to EIA-058/2001 Table 10.13	CM2 Minimisation of works areas.	Work site / During Construction Phase	Contractor		√			EIAO TM
Refer to EIA-058/2001 Table 10.13	CM3 Erection of decorative hoardings.	Work site / During Construction Phase	Contractor		√			EIAO TM

EIA Ref	Environmental Protection Measures / Mitigation Measures	Location / Timing	Implementation Agent	Implementation Stages*				Relevant Legislation and Guidelines
				Des	C	O	Dec	
Refer to EIA-058/2001 Table 10.13	CM4 Control night-time lighting.	Work site / During Construction Phase	Contractor		√			EIAO TM
Refer to EIA-058/2001 Table 10.13	CM5 Minimisation of disruption to public by effective programming of the works.	Work site / During Construction Phase	Contractor		√			EIAO TM
For DP6 – Cross-Harbour Water Mains from Wan Chai to Tsim Sha Tsui								
Refer to EIA-058/2001 Table 10.13	CM2 Minimisation of works areas.	Work site / During Construction Phase	Contractor		√			EIAO TM
Refer to EIA-058/2001 Table 10.13	CM3 Erection of decorative hoardings.	Work site / During Construction Phase	Contractor		√			EIAO TM
Refer to EIA-058/2001 Table 10.13	CM4 Control night-time lighting.	Work site / During Construction Phase	Contractor		√			EIAO TM
Refer to EIA-058/2001 Table 10.13	CM5 Minimisation of disruption to public by effective programming of the works.	Work site / During Construction Phase	Contractor		√			EIAO TM
Operation Phase								
For the Whole Project - Schedule 3 DP								
Table 10.6, Figure 10.5.1-10.5.5	OM1 Aesthetic design of buildings and road-related structures, including viaducts, vent buildings, subways, footbridges and noise barriers and enclosure.	Work site / During Design Stage and Operation Phases	CEDD/HyD	√	√	√		ETWB TCW 2/2004
Table 10.6, Figure 10.5.1-10.5.5	OM2 Shrub and Climbing Plants to soften proposed structures.	Work site / During Design Stage and Operation Phases	CEDD/HyD	√	√	√		ETWB TCW 2/2004
Table 10.6, Figure 10.5.1-10.5.5	OM3 Buffer Tree and Shrub Planting to screen proposed roads and associated structures.	Work site / During Design Stage and Operation Phases	CEDD/HyD/	√	√	√		ETWB TCW 2/2004

EIA Ref	Environmental Protection Measures / Mitigation Measures	Location / Timing	Implementation Agent	Implementation Stages*				Relevant Legislation and Guidelines
				Des	C	O	Dec	
Table 10.6, Figure 10.5.1-10.5.5	OM4 Aesthetic design of proposed waterfront promenade.	Work site / During Design Stage and Operation Phases	CEDD ⁴	√	√	√		ETWB TCW 2/2004
Table 10.6, Figure 10.5.1-10.5.5	OM5 Aesthetic streetscape design.	Work site / During Design Stage and Operation Phases	CEDD/HyD	√	√	√		ETWB TCW 2/2004
Table 10.6, Figure 10.5.1-10.5.5	OM6 Aesthetic design of roadside amenity areas.	Work site / During Design Stage and Operation Phases	CEDD/HyD	√	√	√		ETWB TCW 2/2004
For DP3 – Reclamation Works								
Table 10.6, Figure 10.5.1-10.5.5	OM4 Aesthetic design of proposed waterfront promenade.	Work site / During Design Stage and Operation Phases	CEDD ⁵	√	√	√		ETWB TCW 2/2004

*Des - Design, C - Construction, O – Operation, and Dec - Decommissioning

⁴ CEDD will identify an implementation agent

⁵ CEDD will identify an implementation agent

Appendix B
**Sample Data Sheets for Air Quality,
Noise and Water Quality Monitoring**

APPENDIX B1 Data Record Sheet for TSP Monitoring

Monitoring Location		
Details of Location		
Sampler Identification		
Date & Time of Sampling		
Elapsed-time	Start (min.)	
Meter Reading	Stop (min.)	
Total Sampling Time (min.)		
Weather Conditions		Sunny / Fine / Cloudy / Rainy
Site Conditions		
Initial Flow Rate, Qsi	Pi (mmHg)	
	Ti (°C)	
	Hi (in.)	
	Qsi (Std. m ³)	
Final Flow Rate, Qsf	Pf (mmHg)	
	Tf (°C)	
	Hf (in.)	
	Qsf (Std. m ³)	
Average Flow Rate (Std. m ³)		
Total Volume (Std. m ³)		
Filter Paper Identification No.		
Initial Wt. of Filter Paper (g)		
Final Wt. of Filter Paper (g)		
Measured TSP Level (µg/m ³)		
Other Dust Emission Source(s) Observed		
Remarks /Other Observations		

Name & Designation

Signature

Date

Field Operator:

Laboratory Staff:

Checked by:

APPENDIX B2 Construction Noise Monitoring Field Record Sheet

Monitoring Location		
Description of Location		
Date of Monitoring		
Measurement Start Time	(hh:mm)	
Measurement Time Length	(min.)	
Noise Meter Model/Identification		
Calibrator Model/Identification		
Measurement Results	L ₉₀ (dB(A))	
	L ₁₀ (dB(A))	
	L _{eq} (dB(A))	
Major Construction Noise Source(s) During Monitoring		
Other Noise Source(s) During Monitoring		
Remarks / Other Observations		

Name & Designation

Signature

Date

Recorded by:

Checked by:

APPENDIX B3 Operational Stage Traffic Noise Monitoring – Field Survey Record Sheet

General

Monitoring Location/Reference No.	
Person-in-charge	
Date and Day of Monitoring	
Measurement Time	From to
Description of Location (incl. Floor level) (attach plan separately)	
Microphone Position	

Weather Conditions

Weather Conditions.	
Temperature (°C)	
Wind Speed (ms ⁻¹)	

Equipment

Instrument.	Type	Serial No.	Setting
Sound Level Meter			
Calibration			

Calibration

Before Measurement:	After Measurement:
---------------------	--------------------

Raw Data

Time	Traffic data*				Noise Level (30 min) dB(A)				Average Speed kph a/b c/d #
	Near Side		Far Side		L ₁₀	L ₉₀	L _{eq}	L _{max}	
	LV	HV	LV	HV					

Note: LV - light vehicle (i.e. private car, motorcycle, taxis and van)
 HV - heavy vehicle (i.e. other than LV)
 * - traffic count for a duration of 15 minutes
 # - a/b | c/d = near side LV/near side HV | far side LV/far side HV

APPENDIX B3 Operational Stage Traffic Noise Monitoring – Field Survey Record Sheet (cont'd)

Others

Mitigation Measures in Place Near Measurement Location	
Other Noise source(s) during monitoring	
Remarks	

Personnel

	Name	Designation	Signature	Date
Recorded by				
Checked by				

APPENDIX B4 Water Quality Monitoring Data Record Sheet

Monitoring Station	
Date	
Weather Condition	Sunny / Fine / Cloudy / Rainy
Sea Condition	Calm / Moderate / Rough
Tide Mode	High Tide / Low Tide
Start Time (hh:mm)	
Water Depth which sample is collected (m)	
pH	
Temperature (°C)	
Salinity (ppt)	
Turbidity (NTU)	
Sample Identification	
Suspended Solids (mg/l)	
DO (mg/l)	
DO Saturation (%)	
Remarks / Other Observations	

	<u>Name & Designation</u>	<u>Signature</u>	<u>Date</u>
Recorded by:	_____	_____	_____
Checked by:	_____	_____	_____
Laboratory Staff:	_____	_____	_____

Notes:

- 1 The Suspended Solids results are to be entered once they are available from the laboratory.
- 2 *In-situ* measurements shall be deployed at the designated location twice. The difference between the two consecutive measurements shall be within the range of 25%. If the difference is larger than 25%, the measurement shall be carried out again until the two consecutive readings agree to within 25%.

APPENDIX B5 Odour Patrol Record Sheet

General Information	
Patrol Location	
Date	
Weather	
Temperature	
Humidity	
Tidal Condition	

ID	Location	Time	Odour Intensity			Odour Characteristics & Potential Odour Sources	Wind Direction	Wind Speed	Remarks
			OI-1	OI-2	OI-3				

Note:
 Odour intensity is to be divided into 5 levels which are ranked in the descending order as follows:

- 0 - Not detected. No odour perceived or an odour so weak that it cannot be easily characterised or described;
- 1 - Slight Identifiable odour, and slight chance to have odour nuisance;
- 2 - Moderate Identifiable odour, and moderate chance to have odour nuisance;
- 3 - Strong Identifiable, likely to have odour nuisance;
- 4 - Extreme Severe odour, and unacceptable odour level.

OI-1, OI-2 & OI-3: Odour intensity detected by panel member 1, 2 & 3

	Name & Designation	Signature	Date
Recorded by:			
Checked by:			

Appendix C
Sample Template for the
Interim Notifications

Appendix C Sample Template for the Interim Notification

Incident Report on Action Level or Limit Level Exceedance

Project	
Date	
Time	
Monitoring Location	
Parameter	
Action & Limit Levels	
Measured Level	
Possible reason for Action or Limit Level Non-compliance	
Actions taken / to be taken	
Remarks / Other Observations	

Prepared by: _____

Designation: _____

Signature: _____

Date: _____

Appendix D
Establishment of
Seasonal Action and Limit Levels

Appendix D Establishment of Seasonal Action and Limit Levels – Calculation using the Marine Water Quality Data Obtained at the Closest EPD Routine Monitoring Stations

- According to the location of the EPD routine monitoring stations in the diagram below, the closet monitoring station will be used for comparison purpose.

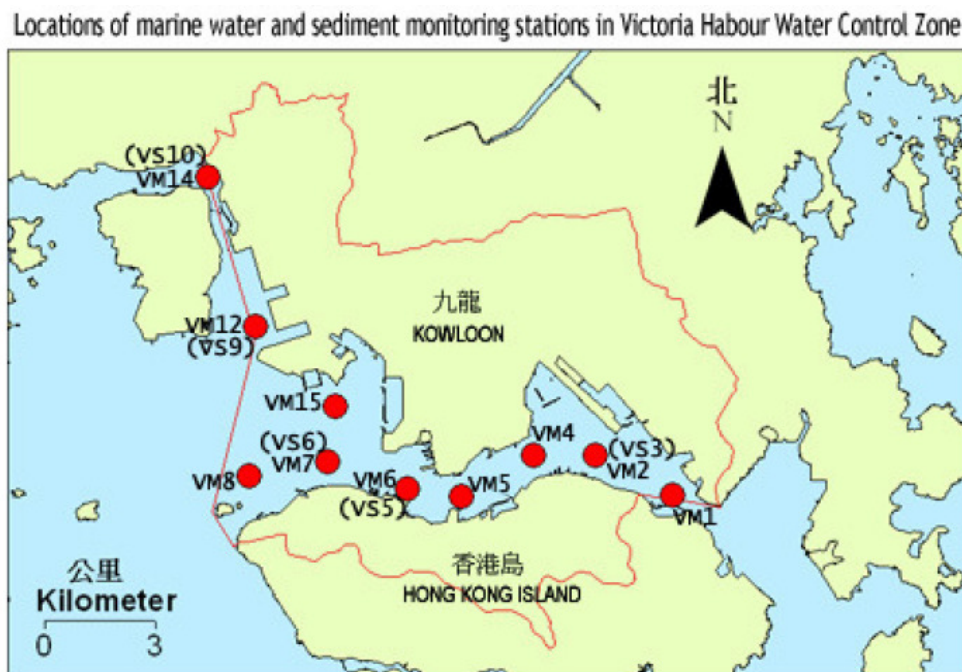

- Overlaying with **Fig. 3.1**, the correlation of the baseline monitoring stations and the EPD monitoring stations will be:
 - WSD15 co-relates with VM1;
 - WSD10, WSD 17 co-relates with VM2;
 - WSD9, C8, C9 co-relates with VM4
 - WSD21, C1- C7 co-relates with VM5
 - WSD19 co-relates with VM6;
 - WSD7 co-relates with VM7;
 - WSD20 co-relates with VM8
- The monthly DO, Turbidity and SS patterns derived from the EPD monitoring data for 2006 to 2008 are used to compare the baseline monitoring data collected at the intake points to take account the seasonal fluctuation in the background level. The background conditions are presented in the wet season (Apr-Sep) and dry season (Oct-Mar).
- For the baseline data taken during the dry season, the derivation of the wet season shall be adjusted with dry season Action and Limit Levels multiplied with mean variation percentage of 2006 - 2008 to account for the seasonal fluctuation.

EPD Marine Water Monitoring Data at Victoria Harbour (2006-2008)

Water Control Zone	Station	Dates	Sample No	Depth	Dissolved Oxygen (mg/L)	Turbidity (NTU)	Suspended Solids (mg/L)
Victoria Harbour	VM1	3/1/2006	1	Middle Water	7.6	9.8	2.4
Victoria Harbour	VM1	2/2/2006	1	Middle Water	6.8	12.9	2.2
Victoria Harbour	VM1	13/3/2006	1	Middle Water	7.1	8.5	2.7
Victoria Harbour	VM1	20/4/2006	1	Middle Water	7.6	9.3	3.3
Victoria Harbour	VM1	18/5/2006	1	Middle Water	5.4	13.1	1.9
Victoria Harbour	VM1	1/6/2006	1	Middle Water	5.3	6.8	5.6
Victoria Harbour	VM1	3/7/2006	1	Middle Water	4.4	10.6	3.5
Victoria Harbour	VM1	4/8/2006	1	Middle Water	5.6	17.6	4.4
Victoria Harbour	VM1	4/9/2006	1	Middle Water	2.7	17.9	6.9
Victoria Harbour	VM1	5/10/2006	1	Middle Water	4.9	13.6	3.6
Victoria Harbour	VM1	2/11/2006	1	Middle Water	6.6	13.9	4.1
Victoria Harbour	VM1	4/12/2006	1	Middle Water	6.6	13.4	6.8
Victoria Harbour	VM2	3/1/2006	1	Middle Water	7.2	9.8	3.6
Victoria Harbour	VM2	2/2/2006	1	Middle Water	6.5	12.5	4.4
Victoria Harbour	VM2	13/3/2006	1	Middle Water	6.8	8.9	3.5
Victoria Harbour	VM2	20/4/2006	1	Middle Water	6.9	8.6	1.8
Victoria Harbour	VM2	18/5/2006	1	Middle Water	5.5	10.3	12
Victoria Harbour	VM2	1/6/2006	1	Middle Water	4.9	4.2	3.9
Victoria Harbour	VM2	3/7/2006	1	Middle Water	5.2	8.5	0.8
Victoria Harbour	VM2	4/8/2006	1	Middle Water	5.8	14.9	5.6
Victoria Harbour	VM2	4/9/2006	1	Middle Water	3.6	12.2	2
Victoria Harbour	VM2	5/10/2006	1	Middle Water	4.3	12.9	3.5
Victoria Harbour	VM2	2/11/2006	1	Middle Water	6.1	14.8	4.7
Victoria Harbour	VM2	4/12/2006	1	Middle Water	6.6	12.4	2.5
Victoria Harbour	VM4	3/1/2006	1	Middle Water	7.3	10.3	4.4
Victoria Harbour	VM4	2/2/2006	1	Middle Water	6.7	12.6	4.4
Victoria Harbour	VM4	13/3/2006	1	Middle Water	6.8	8.4	2.9
Victoria Harbour	VM4	20/4/2006	1	Middle Water	6.8	10	3
Victoria Harbour	VM4	18/5/2006	1	Middle Water	5.3	10	12
Victoria Harbour	VM4	1/6/2006	1	Middle Water	4.9	4.8	2
Victoria Harbour	VM4	3/7/2006	1	Middle Water	5.7	8.5	1.7
Victoria Harbour	VM4	4/8/2006	1	Middle Water	5.5	12.6	4.4
Victoria Harbour	VM4	4/9/2006	1	Middle Water	4.6	12.1	3.2
Victoria Harbour	VM4	5/10/2006	1	Middle Water	4.1	18.1	7.4
Victoria Harbour	VM4	2/11/2006	1	Middle Water	5.9	14.1	4.8
Victoria Harbour	VM4	4/12/2006	1	Middle Water	6.1	12.9	3.9
Victoria Harbour	VM5	3/1/2006	1	Middle Water	7	10.8	5.3
Victoria Harbour	VM5	2/2/2006	1	Middle Water	6.5	14	3.5
Victoria Harbour	VM5	13/3/2006	1	Middle Water	6.2	9.3	2.7
Victoria Harbour	VM5	20/4/2006	1	Middle Water	5.6	9.4	3.2
Victoria Harbour	VM5	18/5/2006	1	Middle Water	4.8	8.5	9.6
Victoria Harbour	VM5	1/6/2006	1	Middle Water	4.9	4.9	3.9
Victoria Harbour	VM5	3/7/2006	1	Middle Water	4.9	10.7	3
Victoria Harbour	VM5	4/8/2006	1	Middle Water	5.6	13.4	4.7
Victoria Harbour	VM5	4/9/2006	1	Middle Water	5.1	12.2	3
Victoria Harbour	VM5	5/10/2006	1	Middle Water	4.3	17.5	5.6
Victoria Harbour	VM5	2/11/2006	1	Middle Water	5.7	13.6	3.9
Victoria Harbour	VM5	4/12/2006	1	Middle Water	5.8	12.7	3.6
Victoria Harbour	VM6	3/1/2006	1	Middle Water	6.8	10.5	4.3
Victoria Harbour	VM6	2/2/2006	1	Middle Water	6.6	13.9	7
Victoria Harbour	VM6	13/3/2006	1	Middle Water	6.4	9.6	3.2
Victoria Harbour	VM6	20/4/2006	1	Middle Water	5.9	10.1	3.5
Victoria Harbour	VM6	18/5/2006	1	Middle Water	4.8	7.7	9.7
Victoria Harbour	VM6	1/6/2006	1	Middle Water	5.1	5	4.1
Victoria Harbour	VM6	3/7/2006	1	Middle Water	6.2	8.9	1.6
Victoria Harbour	VM6	4/8/2006	1	Middle Water	5.5	13.2	4.4
Victoria Harbour	VM6	4/9/2006	1	Middle Water	4.6	12.6	2
Victoria Harbour	VM6	5/10/2006	1	Middle Water	4.4	14.1	5
Victoria Harbour	VM6	2/11/2006	1	Middle Water	5.7	13.1	3.2
Victoria Harbour	VM6	4/12/2006	1	Middle Water	5.5	13.1	4.4
Victoria Harbour	VM7	11/1/2006	1	Middle Water	6.9	9.6	2.5
Victoria Harbour	VM7	16/2/2006	1	Middle Water	6.9	10	6.5
Victoria Harbour	VM7	16/3/2006	1	Middle Water	6.1	10.3	3.8
Victoria Harbour	VM7	21/4/2006	1	Middle Water	6.9	10.5	4.6
Victoria Harbour	VM7	26/5/2006	1	Middle Water	5.1	5.9	20
Victoria Harbour	VM7	12/6/2006	1	Middle Water	4.9	5.2	3
Victoria Harbour	VM7	6/7/2006	1	Middle Water	7.7	9.6	1.4
Victoria Harbour	VM7	11/8/2006	1	Middle Water	5.4	12.7	2.6
Victoria Harbour	VM7	6/9/2006	1	Middle Water	4.4	11.5	1.6
Victoria Harbour	VM7	12/10/2006	1	Middle Water	4.1	20.4	6.8
Victoria Harbour	VM7	3/11/2006	1	Middle Water	5.3	16	5.2
Victoria Harbour	VM7	6/12/2006	1	Middle Water	5.6	12.3	4
Victoria Harbour	VM8	11/1/2006	1	Middle Water	7.5	9.6	3.2
Victoria Harbour	VM8	16/2/2006	1	Middle Water	7.7	11.2	1.7
Victoria Harbour	VM8	16/3/2006	1	Middle Water	6.9	9.8	4.6
Victoria Harbour	VM8	21/4/2006	1	Middle Water	7.5	10.6	4.8

EPD Marine Water Monitoring Data at Victoria Harbour (2006-2008)

Water Control Zone	Station	Dates	Sample No	Depth	Dissolved Oxygen (mg/L)	Turbidity (NTU)	Suspended Solids (mg/L)
Victoria Harbour	VM8	26/5/2006	1	Middle Water	5.3	5.2	18
Victoria Harbour	VM8	12/6/2006	1	Middle Water	4.9	6.2	1.3
Victoria Harbour	VM8	6/7/2006	1	Middle Water	7.4	8.8	2
Victoria Harbour	VM8	11/8/2006	1	Middle Water	5	12	2
Victoria Harbour	VM8	6/9/2006	1	Middle Water	4.4	11.8	2.1
Victoria Harbour	VM8	12/10/2006	1	Middle Water	5.3	18.8	7.5
Victoria Harbour	VM8	3/11/2006	1	Middle Water	5.5	14.5	5.3
Victoria Harbour	VM8	6/12/2006	1	Middle Water	6.2	17.5	9.2
Victoria Harbour	VM1	15/1/2007	1	Middle Water	7.7	10.5	3.3
Victoria Harbour	VM1	1/2/2007	1	Middle Water	7.6	8.4	2
Victoria Harbour	VM1	7/3/2007	1	Middle Water	6.6	10.3	2
Victoria Harbour	VM1	12/4/2007	1	Middle Water	6	9.5	3.4
Victoria Harbour	VM1	3/5/2007	1	Middle Water	5.1	9.5	4.1
Victoria Harbour	VM1	22/6/2007	1	Middle Water	4.2	12.9	5.6
Victoria Harbour	VM1	23/7/2007	1	Middle Water	3.7	35	4.4
Victoria Harbour	VM1	23/8/2007	1	Middle Water	2.9	12.1	5.4
Victoria Harbour	VM1	17/9/2007	1	Middle Water	4.5	14.8	8.5
Victoria Harbour	VM1	10/10/2007	1	Middle Water	4.9	10.8	4
Victoria Harbour	VM1	8/11/2007	1	Middle Water	6	4.2	5.8
Victoria Harbour	VM1	4/12/2007	1	Middle Water	6	7.5	1.6
Victoria Harbour	VM1	3/1/2008	1	Middle Water	6.9	6.6	1.6
Victoria Harbour	VM1	1/2/2008	1	Middle Water	7.2	6.7	1.1
Victoria Harbour	VM1	28/3/2008	1	Middle Water	6.6	10.5	5.7
Victoria Harbour	VM1	23/4/2008	1	Middle Water	6.3	14.4	12
Victoria Harbour	VM1	19/5/2008	1	Middle Water	5.5	7.9	6.6
Victoria Harbour	VM1	11/6/2008	1	Middle Water	4.5	9.1	4.9
Victoria Harbour	VM1	2/7/2008	1	Middle Water	3.7	12.9	3.8
Victoria Harbour	VM1	4/8/2008	1	Middle Water	4.8	9.3	5.4
Victoria Harbour	VM1	19/9/2008	1	Middle Water	2.8	12.3	9.2
Victoria Harbour	VM1	8/10/2008	1	Middle Water	4.5	3.8	6.5
Victoria Harbour	VM1	5/11/2008	1	Middle Water	5.4	3.7	5
Victoria Harbour	VM1	10/12/2008	1	Middle Water	6.1	2.1	3.6
Victoria Harbour	VM2	15/1/2007	1	Middle Water	7.6	10.4	2.6
Victoria Harbour	VM2	1/2/2007	1	Middle Water	7.7	8.4	2
Victoria Harbour	VM2	7/3/2007	1	Middle Water	6.3	11.3	3.3
Victoria Harbour	VM2	12/4/2007	1	Middle Water	5.9	9.1	2.8
Victoria Harbour	VM2	3/5/2007	1	Middle Water	4.7	9.5	3.7
Victoria Harbour	VM2	22/6/2007	1	Middle Water	6.5	11.8	3
Victoria Harbour	VM2	23/7/2007	1	Middle Water	8	24.9	5.2
Victoria Harbour	VM2	23/8/2007	1	Middle Water	3.7	9.4	2.9
Victoria Harbour	VM2	17/9/2007	1	Middle Water	4.5	14.6	5.8
Victoria Harbour	VM2	10/10/2007	1	Middle Water	4.1	10.3	4
Victoria Harbour	VM2	8/11/2007	1	Middle Water	5.7	4.3	4.4
Victoria Harbour	VM2	4/12/2007	1	Middle Water	5.8	7.2	1.8
Victoria Harbour	VM2	3/1/2008	1	Middle Water	6.6	6.5	1.6
Victoria Harbour	VM2	1/2/2008	1	Middle Water	7.1	7	1.6
Victoria Harbour	VM2	28/3/2008	1	Middle Water	6.1	8.9	2.9
Victoria Harbour	VM2	23/4/2008	1	Middle Water	6.1	10.4	4.8
Victoria Harbour	VM2	19/5/2008	1	Middle Water	4.9	6.5	3.8
Victoria Harbour	VM2	11/6/2008	1	Middle Water	5.6	7.6	3.8
Victoria Harbour	VM2	2/7/2008	1	Middle Water	3	11.2	3.6
Victoria Harbour	VM2	4/8/2008	1	Middle Water	6.9	8.1	4.2
Victoria Harbour	VM2	19/9/2008	1	Middle Water	4	8.2	4
Victoria Harbour	VM2	8/10/2008	1	Middle Water	4.3	4.8	4.8
Victoria Harbour	VM2	5/11/2008	1	Middle Water	4.9	4.8	9.2
Victoria Harbour	VM2	10/12/2008	1	Middle Water	5.6	2.5	2.6
Victoria Harbour	VM4	15/1/2007	1	Middle Water	7.3	10.8	2.8
Victoria Harbour	VM4	1/2/2007	1	Middle Water	6.9	9.2	2.3
Victoria Harbour	VM4	7/3/2007	1	Middle Water	5.7	11.2	3.5
Victoria Harbour	VM4	12/4/2007	1	Middle Water	5.6	9.4	2.8
Victoria Harbour	VM4	3/5/2007	1	Middle Water	4.5	9.3	4.6
Victoria Harbour	VM4	22/6/2007	1	Middle Water	5.3	11.8	3.5
Victoria Harbour	VM4	23/7/2007	1	Middle Water	8	21	5.6
Victoria Harbour	VM4	23/8/2007	1	Middle Water	4.6	9.6	2.7
Victoria Harbour	VM4	17/9/2007	1	Middle Water	4.3	14.2	5.9
Victoria Harbour	VM4	10/10/2007	1	Middle Water	4.1	10.6	4.8
Victoria Harbour	VM4	8/11/2007	1	Middle Water	5.6	4.1	3.8
Victoria Harbour	VM4	4/12/2007	1	Middle Water	5.4	7.1	1.7
Victoria Harbour	VM4	3/1/2008	1	Middle Water	6.1	7.4	2.8
Victoria Harbour	VM4	1/2/2008	1	Middle Water	7.1	7.5	2.7
Victoria Harbour	VM4	28/3/2008	1	Middle Water	5.9	9.7	3.4
Victoria Harbour	VM4	23/4/2008	1	Middle Water	5.8	11.9	7.8
Victoria Harbour	VM4	19/5/2008	1	Middle Water	4.7	8.4	11
Victoria Harbour	VM4	11/6/2008	1	Middle Water	5.9	8.2	3.1
Victoria Harbour	VM4	2/7/2008	1	Middle Water	4.2	11	3.5
Victoria Harbour	VM4	4/8/2008	1	Middle Water	7	8.4	4.6

EPD Marine Water Monitoring Data at Victoria Harbour (2006-2008)

Water Control Zone	Station	Dates	Sample No	Depth	Dissolved Oxygen (mg/L)	Turbidity (NTU)	Suspended Solids (mg/L)
Victoria Harbour	VM4	19/9/2008	1	Middle Water	2.8	9.4	5.3
Victoria Harbour	VM4	8/10/2008	1	Middle Water	4.4	4.2	4.7
Victoria Harbour	VM4	5/11/2008	1	Middle Water	4.7	5.9	7.7
Victoria Harbour	VM4	10/12/2008	1	Middle Water	5.3	2.5	2.9
Victoria Harbour	VM5	15/1/2007	1	Middle Water	6.6	10.3	1.7
Victoria Harbour	VM5	1/2/2007	1	Middle Water	6.9	8.9	3.2
Victoria Harbour	VM5	7/3/2007	1	Middle Water	5.6	10.2	2.8
Victoria Harbour	VM5	12/4/2007	1	Middle Water	5	9.3	3.1
Victoria Harbour	VM5	3/5/2007	1	Middle Water	4.1	10.1	5.3
Victoria Harbour	VM5	22/6/2007	1	Middle Water	5.1	12	3.9
Victoria Harbour	VM5	23/7/2007	1	Middle Water	6.1	24.6	6.2
Victoria Harbour	VM5	23/8/2007	1	Middle Water	4.9	9.5	2.8
Victoria Harbour	VM5	17/9/2007	1	Middle Water	3.9	12.1	3.1
Victoria Harbour	VM5	10/10/2007	1	Middle Water	3.9	13.1	8
Victoria Harbour	VM5	8/11/2007	1	Middle Water	5.3	4.1	4.2
Victoria Harbour	VM5	4/12/2007	1	Middle Water	4.2	8	1.7
Victoria Harbour	VM5	3/1/2008	1	Middle Water	5.7	6.8	2.8
Victoria Harbour	VM5	1/2/2008	1	Middle Water	6.8	7.2	2.4
Victoria Harbour	VM5	28/3/2008	1	Middle Water	5.2	9.2	2.7
Victoria Harbour	VM5	23/4/2008	1	Middle Water	5.2	10.4	5
Victoria Harbour	VM5	19/5/2008	1	Middle Water	5.1	7.9	5.8
Victoria Harbour	VM5	11/6/2008	1	Middle Water	5.2	8.2	4.9
Victoria Harbour	VM5	2/7/2008	1	Middle Water	5.1	10	2.4
Victoria Harbour	VM5	4/8/2008	1	Middle Water	6	8.4	5.3
Victoria Harbour	VM5	19/9/2008	1	Middle Water	3.1	12.1	10
Victoria Harbour	VM5	8/10/2008	1	Middle Water	4.4	3.8	4.7
Victoria Harbour	VM5	5/11/2008	1	Middle Water	4.7	5.2	6.6
Victoria Harbour	VM5	10/12/2008	1	Middle Water	5.6	3	4
Victoria Harbour	VM6	15/1/2007	1	Middle Water	7.3	10.3	2.1
Victoria Harbour	VM6	1/2/2007	1	Middle Water	6.8	9.8	4.4
Victoria Harbour	VM6	7/3/2007	1	Middle Water	5.2	10.1	2.4
Victoria Harbour	VM6	12/4/2007	1	Middle Water	5	9.5	3.8
Victoria Harbour	VM6	3/5/2007	1	Middle Water	4.3	10.1	4.2
Victoria Harbour	VM6	22/6/2007	1	Middle Water	5.6	12.6	2.5
Victoria Harbour	VM6	23/7/2007	1	Middle Water	3.2	18.4	3.9
Victoria Harbour	VM6	23/8/2007	1	Middle Water	3.9	11.4	4
Victoria Harbour	VM6	17/9/2007	1	Middle Water	3.7	12.4	4
Victoria Harbour	VM6	10/10/2007	1	Middle Water	4.4	13.4	9.5
Victoria Harbour	VM6	8/11/2007	1	Middle Water	5	4.1	4.8
Victoria Harbour	VM6	4/12/2007	1	Middle Water	4.7	7.5	2.5
Victoria Harbour	VM6	3/1/2008	1	Middle Water	5.6	7	2
Victoria Harbour	VM6	1/2/2008	1	Middle Water	6.6	7.4	3.1
Victoria Harbour	VM6	28/3/2008	1	Middle Water	5.3	9.2	2.4
Victoria Harbour	VM6	23/4/2008	1	Middle Water	5.3	11.4	7
Victoria Harbour	VM6	19/5/2008	1	Middle Water	5.1	7.1	6
Victoria Harbour	VM6	11/6/2008	1	Middle Water	5	9.7	3.5
Victoria Harbour	VM6	2/7/2008	1	Middle Water	4.6	9.9	4.4
Victoria Harbour	VM6	4/8/2008	1	Middle Water	7.4	7.7	4.2
Victoria Harbour	VM6	19/9/2008	1	Middle Water	2.8	10.1	7.4
Victoria Harbour	VM6	8/10/2008	1	Middle Water	4.7	4	14
Victoria Harbour	VM6	5/11/2008	1	Middle Water	4.7	4.6	6.4
Victoria Harbour	VM6	10/12/2008	1	Middle Water	5.6	3.4	5.3
Victoria Harbour	VM7	3/1/2007	1	Middle Water	5.7	12.2	2.4
Victoria Harbour	VM7	6/2/2007	1	Middle Water	7	10.7	5.3
Victoria Harbour	VM7	9/3/2007	1	Middle Water	5.2	10.2	3.2
Victoria Harbour	VM7	13/4/2007	1	Middle Water	4.9	9.3	3.6
Victoria Harbour	VM7	7/5/2007	1	Middle Water	4.9	8.8	1.3
Victoria Harbour	VM7	25/6/2007	1	Middle Water	5.5	9.2	1.3
Victoria Harbour	VM7	18/7/2007	1	Middle Water	5.3	11.4	3
Victoria Harbour	VM7	20/8/2007	1	Middle Water	4.7	12.5	4
Victoria Harbour	VM7	24/9/2007	1	Middle Water	4.7	15.5	10
Victoria Harbour	VM7	11/10/2007	1	Middle Water	3.9	11.2	6
Victoria Harbour	VM7	15/11/2007	1	Middle Water	5.1	4.2	4.6
Victoria Harbour	VM7	11/12/2007	1	Middle Water	5.1	8.6	3.4
Victoria Harbour	VM7	4/1/2008	1	Middle Water	5.6	8.1	4.2
Victoria Harbour	VM7	11/2/2008	1	Middle Water	6.3	8.7	4.6
Victoria Harbour	VM7	5/3/2008	1	Middle Water	7.8	8	2.2
Victoria Harbour	VM7	2/4/2008	1	Middle Water	6.1	10.3	5
Victoria Harbour	VM7	14/5/2008	1	Middle Water	5.5	8	5.9
Victoria Harbour	VM7	2/6/2008	1	Middle Water	4.4	8.1	3.4
Victoria Harbour	VM7	7/7/2008	1	Middle Water	5.1	11.6	2.6
Victoria Harbour	VM7	25/8/2008	1	Middle Water	5.2	7.3	2.9
Victoria Harbour	VM7	22/9/2008	1	Middle Water	3.1	7.7	4.1
Victoria Harbour	VM7	9/10/2008	1	Middle Water	5.3	4.3	5.6
Victoria Harbour	VM7	20/11/2008	1	Middle Water	5.3	4.7	6.5
Victoria Harbour	VM7	6/12/2008	1	Middle Water	6.1	9.8	4.3

EPD Marine Water Monitoring Data at Victoria Harbour (2006-2008)

Water Control Zone	Station	Dates	Sample No	Depth	Dissolved Oxygen (mg/L)	Turbidity (NTU)	Suspended Solids (mg/L)
Victoria Harbour	VM8	3/1/2007	1	Middle Water	5.6	13.5	5
Victoria Harbour	VM8	6/2/2007	1	Middle Water	8.6	11.8	7
Victoria Harbour	VM8	9/3/2007	1	Middle Water	6.4	13.1	7.8
Victoria Harbour	VM8	13/4/2007	1	Middle Water	5.5	9.9	4.5
Victoria Harbour	VM8	7/5/2007	1	Middle Water	5.8	9.8	3.6
Victoria Harbour	VM8	25/6/2007	1	Middle Water	5.2	9.5	2.2
Victoria Harbour	VM8	18/7/2007	1	Middle Water	5	33.9	3.4
Victoria Harbour	VM8	20/8/2007	1	Middle Water	4.4	13	4
Victoria Harbour	VM8	24/9/2007	1	Middle Water	5	14.5	6.6
Victoria Harbour	VM8	11/10/2007	1	Middle Water	4.5	12	6.5
Victoria Harbour	VM8	15/11/2007	1	Middle Water	5.6	4.1	7.6
Victoria Harbour	VM8	11/12/2007	1	Middle Water	5.1	8.7	3.7
Victoria Harbour	VM8	4/1/2008	1	Middle Water	6.2	8.1	3.4
Victoria Harbour	VM8	11/2/2008	1	Middle Water	7.4	12.1	6.6
Victoria Harbour	VM8	5/3/2008	1	Middle Water	7.6	8.8	3
Victoria Harbour	VM8	2/4/2008	1	Middle Water	6.6	13.3	7.4
Victoria Harbour	VM8	14/5/2008	1	Middle Water	5.5	8.4	6.3
Victoria Harbour	VM8	2/6/2008	1	Middle Water	5.1	7.3	3
Victoria Harbour	VM8	7/7/2008	1	Middle Water	5.1	12.2	2.4
Victoria Harbour	VM8	25/8/2008	1	Middle Water	5.1	7.2	3.2
Victoria Harbour	VM8	22/9/2008	1	Middle Water	4	7.3	3.1
Victoria Harbour	VM8	9/10/2008	1	Middle Water	5.3	3.9	4.3
Victoria Harbour	VM8	20/11/2008	1	Middle Water	5.8	4.5	5.4
Victoria Harbour	VM8	6/12/2008	1	Middle Water	6.4	10.3	6.3

EPD Marine Water Monitoring Data (2006-2008) - DO Variation Between Dry and Wet Seasons

DO (mg/L)		Dry season 2006	Wet season 2006	Variation in avg. DO	Dry season 2007	Wet season 2007	Variation in avg. DO	Dry season 2008	Wet season 2008	Variation in avg. DO	Mean Variation %
Station											
VM1 (WSD15)	Avg.	6.60	5.17	-21.7%	6.47	4.40	-32.0%	6.12	4.60	-24.8%	-26.2%
	Min.	4.90	2.70	-	4.90	2.90	-	4.50	2.80	-	-
	Max.	7.60	7.60	-	7.70	6.00	-	7.20	6.30	-	-
VM2 (WSD10, WSD17)	Avg.	6.25	5.32	-14.9%	6.20	5.55	-10.5%	5.77	5.08	-11.8%	-12.4%
	Min.	4.30	3.60	-	4.10	3.70	-	4.30	3.00	-	-
	Max.	7.20	6.90	-	7.70	8.00	-	7.10	6.90	-	-
VM4 (WSD9, C8, C9)	Avg.	6.15	5.47	-11.1%	5.83	5.38	-7.7%	5.58	5.07	-9.3%	-9.4%
	Min.	4.10	4.60	-	4.10	4.30	-	4.40	2.80	-	-
	Max.	7.30	6.80	-	7.30	8.00	-	7.10	7.00	-	-
VM5 (WSD21, C1-C7)	Avg.	5.92	5.15	-13.0%	5.42	4.85	-10.5%	5.40	4.95	-8.3%	-10.6%
	Min.	4.30	4.80	-	3.90	3.90	-	4.40	3.10	-	-
	Max.	7.00	5.60	-	6.90	6.10	-	6.80	6.00	-	-
VM6 (WSD19)	Avg.	5.90	5.35	-9.3%	5.57	4.28	-23.1%	5.42	5.03	-7.1%	-13.2%
	Min.	4.40	4.60	-	4.40	3.20	-	4.70	2.80	-	-
	Max.	6.80	6.20	-	7.30	5.60	-	6.60	7.40	-	-
VM7 (WSD7)	Avg.	5.82	5.73	-1.4%	5.33	5.00	-6.2%	6.07	4.90	-19.2%	-9.0%
	Min.	4.10	4.40	-	3.90	4.70	-	5.30	3.10	-	-
	Max.	6.90	7.70	-	7.00	5.50	-	7.80	6.10	-	-
VM8 (WSD20)	Avg.	6.52	5.75	-11.8%	5.97	5.15	-13.7%	6.45	5.23	-18.9%	-14.8%
	Min.	5.30	4.40	-	4.50	4.40	-	5.30	4.00	-	-
	Max.	7.70	7.50	-	8.60	5.80	-	7.60	6.60	-	-

EPD Marine Water Monitoring Data (2006-2008) - Turbidity Variation Between Dry and Wet Seasons

Station	Turb (NTU)	Dry season 2006	Wet season 2006	Varia-tion in avg. Tur	Dry season 2007	Wet season 2007	Varia-tion in avg. Tur	Dry season 2008	Wet season 2008	Varia-tion in avg. Tur	Mean Variation %
	VM1 (WSD15)	Avg.	12.02	12.55	4.4%	8.62	15.63	81.4%	5.57	10.98	97.3%
Min.		8.50	6.80	-	4.20	9.50	-	2.10	7.90	-	-
Max.		13.90	17.90	-	10.80	35.00	-	10.50	14.40	-	-
VM2 (WSD10, WSD17)	Avg.	11.88	9.78	-17.7%	8.65	13.22	52.8%	5.75	8.67	50.7%	28.6%
	Min.	8.90	4.20	-	4.30	9.10	-	2.50	6.50	-	-
	Max.	14.80	14.90	-	11.30	24.90	-	8.90	11.20	-	-
VM4 (WSD9, C8, C9)	Avg.	12.73	9.67	-24.1%	8.83	12.55	42.1%	6.20	9.55	54.0%	24.0%
	Min.	8.40	4.80	-	4.10	9.30	-	2.50	8.20	-	-
	Max.	18.10	12.60	-	11.20	21.00	-	9.70	11.90	-	-
VM5 (WSD21, C1-C7)	Avg.	12.98	9.85	-24.1%	9.10	12.93	42.1%	5.87	9.50	61.9%	26.6%
	Min.	9.30	4.90	-	4.10	9.30	-	3.00	7.90	-	-
	Max.	17.50	13.40	-	13.10	24.60	-	9.20	12.10	-	-
VM6 (WSD19)	Avg.	12.38	9.58	-22.6%	9.20	12.40	34.8%	5.93	9.32	57.0%	23.1%
	Min.	9.60	5.00	-	4.10	9.50	-	3.40	7.10	-	-
	Max.	14.10	13.20	-	13.40	18.40	-	9.20	11.40	-	-
VM7 (WSD7)	Avg.	13.10	9.23	-29.5%	9.52	11.12	16.8%	7.27	8.83	21.6%	3.0%
	Min.	9.60	5.20	-	4.20	8.80	-	4.30	7.30	-	-
	Max.	20.40	12.70	-	12.20	15.50	-	9.80	11.60	-	-
VM8 (WSD20)	Avg.	13.57	9.10	-32.9%	10.53	15.10	43.4%	7.95	9.28	16.8%	9.1%
	Min.	9.60	5.20	-	4.10	9.50	-	3.90	7.20	-	-
	Max.	18.80	12.00	-	13.50	33.90	-	12.10	13.30	-	-

EPD Marine Water Monitoring Data (2006-2008) - SS Variation Between Dry and Wet Seasons

SS (mg/L)		Dry season 2006	Wet season 2006	Varia-tion in avg. SS	Dry season 2007	Wet season 2007	Varia-tion in avg. SS	Dry season 2008	Wet season 2008	Varia-tion in avg. SS	Mean Variation %
Station											
VM1 (WSD15)	Avg.	3.63	7.12	95.9%	3.12	5.23	67.9%	3.92	6.98	78.3%	80.7%
	Min.	2.20	3.30	-	1.60	3.40	-	1.10	3.80	-	-
	Max.	6.80	19.00	-	5.80	8.50	-	6.50	12.00	-	-
VM2 (WSD10, WSD17)	Avg.	3.70	4.35	17.6%	3.02	3.90	29.3%	3.78	4.03	6.6%	17.8%
	Min.	2.50	0.80	-	1.80	2.80	-	1.60	3.60	-	-
	Max.	4.70	12.00	-	4.40	5.80	-	9.20	4.80	-	-
VM4 (WSD9, C8, C9)	Avg.	4.63	4.38	-5.4%	3.15	4.18	32.8%	4.03	5.88	45.9%	24.4%
	Min.	2.90	1.70	-	1.70	2.70	-	2.70	3.10	-	-
	Max.	7.40	12.00	-	4.80	5.90	-	7.70	11.00	-	-
VM5 (WSD21, C1-C7)	Avg.	4.10	4.57	11.4%	3.60	4.07	13.0%	3.87	5.57	44.0%	22.8%
	Min.	2.70	3.00	-	1.70	2.80	-	2.40	2.40	-	-
	Max.	5.60	9.60	-	8.00	6.20	-	6.60	10.00	-	-
VM6 (WSD19)	Avg.	4.52	4.22	-6.6%	4.28	3.73	-12.8%	5.53	5.42	-2.1%	-7.2%
	Min.	3.20	1.60	-	2.10	2.50	-	2.00	3.50	-	-
	Max.	7.00	9.70	-	9.50	4.20	-	14.00	7.40	-	-
VM7 (WSD7)	Avg.	4.80	5.53	15.3%	4.15	3.87	-6.8%	4.57	3.98	-12.8%	-1.4%
	Min.	2.50	1.40	-	2.40	1.30	-	2.20	2.60	-	-
	Max.	6.80	20.00	-	6.00	10.00	-	6.50	5.90	-	-
VM8 (WSD20)	Avg.	7.80	5.03	-35.5%	6.27	4.05	-35.4%	4.83	4.23	-12.4%	-27.8%
	Min.	3.20	1.30	-	3.70	2.20	-	3.00	2.40	-	-
	Max.	17.00	18.00	-	7.80	6.60	-	6.60	7.40	-	-

Baseline Turbidity Monitoring Data (Oct - Nov 2009)

Mid-flood Date	WSD7			WSD9			WSD10			WSD15			WSD17		
	Value	Value	Average	Value	Value	Average	Value	Value	Average	Value	Value	Average	Value	Value	Average
21-Oct-09	10.2	9.3	9.75	4.6	4.6	4.60	5.0	4.3	4.65	5.7	5.2	5.45	6.2	6.4	6.30
23-Oct-09	4.9	5.8	5.35	3.4	4.1	3.75	3.1	3.2	3.15	6.3	6.4	6.35	5.0	5.5	5.25
27-Oct-09	7.6	7.4	7.50	4.0	4.2	4.10	3.3	3.2	3.25	6.3	5.7	6.00	6.6	6.7	6.65
29-Oct-09	8.0	8.0	8.00	3.8	3.8	3.80	5.0	5.0	5.00	3.0	3.0	3.00	3.6	3.6	3.60
31-Oct-09	6.3	5.4	5.85	2.2	2.0	2.10	4.9	6.1	5.50	5.6	4.2	4.90	5.9	5.9	5.90
2-Nov-09	5.8	5.0	5.40	3.7	3.8	3.75	3.3	2.9	3.10	5.0	4.8	4.90	4.9	4.8	4.85
4-Nov-09	7.1	6.8	6.95	3.8	3.7	3.75	4.7	4.5	4.60	5.1	5.5	5.30	4.8	4.6	4.70
6-Nov-09	8.4	8.1	8.25	3.7	3.6	3.65	3.0	3.0	3.00	3.5	3.4	3.45	4.1	4.5	4.30
10-Nov-09	6.3	6.0	6.15	3.7	3.4	3.55	3.6	3.9	3.75	2.9	2.6	2.75	5.8	6.2	6.00
12-Nov-09	9.8	9.2	9.50	4.4	4.3	4.35	7.1	6.5	6.80	5.6	5.5	5.55	6.0	6.2	6.10
14-Nov-09	1.9	1.8	1.85	2.1	2.4	2.25	4.9	5.1	5.00	2.3	2.2	2.25	6.6	6.1	6.35
16-Nov-09	1.9	1.8	1.85	2.3	2.3	2.30	2.6	2.7	2.65	2.4	2.3	2.35	2.4	2.4	2.40

Mid-ebb Date	WSD7			WSD9			WSD10			WSD15			WSD17		
	Value	Value	Average	Value	Value	Average	Value	Value	Average	Value	Value	Average	Value	Value	Average
21-Oct-09	5.5	5.5	5.50	6.3	6.9	6.60	5.2	4.8	5.00	7.3	7.5	7.40	7.8	7.5	7.65
23-Oct-09	6.2	5.7	5.95	4.3	4.8	4.55	4.3	3.9	4.10	3.1	3.0	3.05	5.4	4.4	4.90
27-Oct-09	6.7	6.2	6.45	2.3	2.5	2.40	3.7	3.5	3.60	3.2	3.4	3.30	3.4	3.5	3.45
29-Oct-09	4.3	4.2	4.25	3.3	3.5	3.40	4.9	4.9	4.90	3.3	3.5	3.40	4.6	4.6	4.60
31-Oct-09	3.7	4.1	3.90	3.4	3.7	3.55	6.1	6.4	6.25	3.8	1.9	2.85	3.9	3.5	3.70
2-Nov-09	6.3	5.9	6.10	3.6	3.7	3.65	3.6	3.7	3.65	3.6	3.7	3.65	4.6	3.7	4.15
4-Nov-09	3.2	3.3	3.25	2.9	2.7	2.80	2.7	2.8	2.75	6.1	5.8	5.95	3.5	3.4	3.45
6-Nov-09	3.8	3.7	3.75	3.1	2.9	3.00	3.3	3.1	3.20	5.7	5.6	5.65	4.6	4.4	4.50
10-Nov-09	3.8	3.7	3.75	5.2	5.3	5.25	2.7	2.8	2.75	2.4	2.3	2.35	4.1	4.3	4.20
12-Nov-09	5.1	5.1	5.10	4.4	4.5	4.45	6.1	6.1	6.10	5.5	5.7	5.60	7.3	7.6	7.45
14-Nov-09	2.2	2.0	2.10	2.4	2.4	2.40	4.4	4.0	4.20	1.6	1.4	1.50	2.9	3.1	3.00
16-Nov-09	2.1	2.1	2.10	2.4	2.3	2.35	2.8	2.7	2.75	2.9	2.7	2.80	2.8	2.5	2.65

Baseline Turbidity Monitoring Data (Oct - Nov 2009)

Mid-flood	WSD19			WSD20			WSD21			RW1			C1		
Date	Value	Value	Average	Value	Value	Average	Value	Value	Average	Value	Value	Average	Value	Value	Average
21-Oct-09	6.2	5.8	6.00	5.9	6.3	6.10	8.4	8.5	8.45	10.4	10.6	10.50	6.1	6.3	6.20
23-Oct-09	7.0	6.5	6.75	5.5	5.6	5.55	6.6	6.9	6.75	8.2	8.1	8.15	6.0	5.4	5.70
27-Oct-09	6.9	6.6	6.75	3.8	3.5	3.65	7.9	7.6	7.75	7.8	7.7	7.75	5.1	5.2	5.15
29-Oct-09	4.3	4.3	4.30	3.0	2.9	2.95	5.8	6.1	5.95	6.4	6.1	6.25	4.9	4.9	4.90
31-Oct-09	5.6	7.0	6.30	4.0	3.5	3.75	4.9	5.0	4.95	4.7	5.8	5.25	4.1	4.5	4.30
2-Nov-09	5.4	4.4	4.90	5.1	4.6	4.85	5.0	4.5	4.75	4.3	4.0	4.15	6.0	5.8	5.90
4-Nov-09	4.0	4.1	4.05	6.3	6.7	6.50	6.6	6.6	6.60	5.6	5.4	5.50	4.0	3.9	3.95
6-Nov-09	5.2	5.3	5.25	5.5	5.7	5.60	6.3	6.3	6.30	6.5	6.3	6.40	3.6	3.7	3.65
10-Nov-09	7.4	7.8	7.60	4.0	4.3	4.15	6.7	7.0	6.85	4.8	5.3	5.05	4.0	3.8	3.90
12-Nov-09	9.6	9.2	9.40	6.5	6.9	6.70	5.8	5.6	5.70	4.7	4.5	4.60	3.2	3.1	3.15
14-Nov-09	5.1	5.2	5.15	5.5	5.1	5.30	4.8	5.2	5.00	6.1	5.8	5.95	4.0	3.7	3.85
16-Nov-09	1.8	1.6	1.70	1.7	1.7	1.70	8.4	8.9	8.65	7.9	7.9	7.90	8.4	8.9	8.65

Mid-ebb	WSD19			WSD20			WSD21			RW1			C1		
Date	Value	Value	Average	Value	Value	Average	Value	Value	Average	Value	Value	Average	Value	Value	Average
21-Oct-09	8.8	8.4	8.60	6.7	6.5	6.60	6.2	6.2	6.20	6.6	6.6	6.60	5.1	5.4	5.25
23-Oct-09	5.3	4.7	5.00	4.2	4.2	4.20	5.5	5.8	5.65	4.9	5.1	5.00	5.5	5.8	5.65
27-Oct-09	3.7	3.3	3.50	3.1	3.2	3.15	6.0	6.0	6.00	5.9	5.9	5.90	8.4	8.3	8.35
29-Oct-09	5.0	4.9	4.95	2.9	2.8	2.85	4.9	5.1	5.00	4.8	4.8	4.80	6.0	6.2	6.10
31-Oct-09	3.8	3.9	3.85	4.7	5.9	5.30	4.5	4.3	4.40	4.6	4.5	4.55	4.9	4.7	4.80
2-Nov-09	4.9	5.4	5.15	3.5	3.5	3.50	4.8	4.7	4.75	3.1	2.9	3.00	4.5	3.8	4.15
4-Nov-09	3.2	3.4	3.30	3.8	3.6	3.70	6.0	5.7	5.85	5.2	5.1	5.15	4.6	4.8	4.70
6-Nov-09	7.0	6.3	6.65	5.3	4.9	5.10	5.5	5.3	5.40	4.2	4.5	4.35	4.8	4.7	4.75
10-Nov-09	4.2	4.4	4.30	3.0	3.2	3.10	4.4	4.5	4.45	3.8	4.2	4.00	4.6	4.5	4.55
12-Nov-09	4.0	4.2	4.10	3.5	3.6	3.55	4.7	4.4	4.55	4.6	4.4	4.50	4.6	4.4	4.50
14-Nov-09	2.1	2.2	2.15	2.4	2.1	2.25	5.1	5.0	5.05	6.4	6.1	6.25	4.4	4.1	4.25
16-Nov-09	2.5	2.6	2.55	1.9	1.9	1.90	8.6	8.5	8.55	9.0	8.9	8.95	9.2	8.8	9.00

Baseline Turbidity Monitoring Data (Oct - Nov 2009)

Mid-flood	C2			C3			C4			C5			C6		
Date	Value	Value	Average	Value	Value	Average	Value	Value	Average	Value	Value	Average	Value	Value	Average
21-Oct-09	5.7	5.5	5.60	8.5	7.8	8.15	6.8	7.6	7.20	9.3	9.0	9.15	5.4	5.4	5.40
23-Oct-09	5.5	5.6	5.55	6.1	6.0	6.05	7.2	7.2	7.20	6.7	6.5	6.60	5.8	5.7	5.75
27-Oct-09	7.8	8.1	7.95	7.8	7.5	7.65	7.0	7.0	7.00	7.3	7.2	7.25	7.4	7.3	7.35
29-Oct-09	6.2	6.3	6.25	7.4	6.4	6.90	9.3	8.3	8.80	7.4	7.5	7.45	6.3	5.7	6.00
31-Oct-09	6.6	6.2	6.40	4.7	4.8	4.75	5.1	5.5	5.30	4.7	4.7	4.70	4.1	4.0	4.05
2-Nov-09	3.7	3.6	3.65	3.3	3.2	3.25	3.3	3.2	3.25	3.6	3.2	3.40	5.6	5.8	5.70
4-Nov-09	5.2	4.8	5.00	6.2	6.5	6.35	5.9	5.7	5.80	5.9	5.6	5.75	4.8	4.5	4.65
6-Nov-09	6.2	6.0	6.10	4.7	4.5	4.60	6.4	6.1	6.25	6.4	6.3	6.35	3.2	3.3	3.25
10-Nov-09	5.8	5.9	5.85	5.7	5.9	5.80	6.8	6.5	6.65	6.6	6.9	6.75	5.3	5.1	5.20
12-Nov-09	4.6	4.4	4.50	4.8	4.6	4.70	5.4	5.6	5.50	5.3	5.5	5.40	3.6	3.7	3.65
14-Nov-09	5.9	5.6	5.75	3.8	3.9	3.85	4.6	4.7	4.65	4.9	5.0	4.95	4.5	4.3	4.40
16-Nov-09	9.0	8.6	8.80	8.3	8.2	8.25	9.4	9.1	9.25	9.1	8.6	8.85	8.0	7.7	7.85

Mid-ebb	C2			C3			C4			C5			C6		
Date	Value	Value	Average	Value	Value	Average	Value	Value	Average	Value	Value	Average	Value	Value	Average
21-Oct-09	6.1	6.3	6.20	5.2	5.3	5.25	6.8	6.8	6.80	7.7	7.9	7.80	5.5	5.2	5.35
23-Oct-09	6.0	5.4	5.70	7.0	6.6	6.80	5.4	5.4	5.40	5.3	5.5	5.40	5.6	5.6	5.60
27-Oct-09	5.1	5.2	5.15	5.4	5.4	5.40	6.6	6.3	6.45	6.3	6.2	6.25	6.2	6.3	6.25
29-Oct-09	4.9	4.9	4.90	4.7	4.6	4.65	5.0	4.8	4.90	5.1	5.0	5.05	4.8	4.8	4.80
31-Oct-09	4.1	4.5	4.30	3.8	3.9	3.85	4.4	4.0	4.20	4.8	4.7	4.75	5.8	6.1	5.95
2-Nov-09	6.0	5.8	5.90	6.6	6.4	6.50	6.1	5.5	5.80	4.2	4.1	4.15	3.8	3.9	3.85
4-Nov-09	4.0	3.9	3.95	6.2	6.0	6.10	6.6	6.2	6.40	4.9	5.4	5.15	5.4	5.0	5.20
6-Nov-09	3.6	3.7	3.65	4.5	4.4	4.45	4.1	4.3	4.20	7.4	7.7	7.55	4.0	4.0	4.00
10-Nov-09	4.0	3.8	3.90	4.4	4.2	4.30	5.1	4.8	4.95	4.4	4.4	4.40	5.0	4.8	4.90
12-Nov-09	3.2	3.1	3.15	2.8	2.7	2.75	2.8	3.0	2.90	4.9	4.7	4.80	4.3	4.3	4.30
14-Nov-09	4.0	3.7	3.85	4.7	4.9	4.80	4.8	4.7	4.75	6.7	6.4	6.55	5.3	5.2	5.25
16-Nov-09	8.4	8.9	8.65	8.9	8.8	8.85	8.8	9.0	8.90	9.3	9.4	9.35	8.9	8.6	8.75

Baseline Turbidity Monitoring Data (Oct - Nov 2009)

Mid-flood Date	C7			C8			C9			RC1			RC5		
	Value	Value	Average	Value	Value	Average	Value	Value	Average	Value	Value	Average	Value	Value	Average
21-Oct-09	5.8	5.5	5.65	8.9	9.0	8.95	8.2	8.1	8.15	5.7	6.0	5.85	6.4	6.4	6.40
23-Oct-09	6.8	6.5	6.65	9.4	10.1	9.75	10.2	10.2	10.20	5.5	5.5	5.50	7.5	7.4	7.45
27-Oct-09	5.5	5.5	5.50	10.0	10.1	10.05	10.9	11.2	11.05	7.9	8.0	7.95	7.6	7.5	7.55
29-Oct-09	7.7	7.3	7.50	8.6	9.0	8.80	10.4	10.8	10.60	6.5	5.8	6.15	6.4	6.1	6.25
31-Oct-09	4.8	4.6	4.70	5.8	6.3	6.05	9.9	9.9	9.90	5.0	5.3	5.15	4.0	3.9	3.95
2-Nov-09	4.7	4.6	4.65	4.8	4.8	4.80	5.1	5.6	5.35	3.4	3.2	3.30	4.2	4.3	4.25
4-Nov-09	4.9	5.0	4.95	6.5	6.4	6.45	7.6	7.8	7.70	4.3	4.7	4.50	6.1	6.6	6.35
6-Nov-09	4.5	4.4	4.45	9.3	9.6	9.45	8.4	8.0	8.20	5.9	5.7	5.80	5.2	5.3	5.25
10-Nov-09	4.8	4.7	4.75	7.3	7.7	7.50	8.4	7.9	8.15	5.0	4.9	4.95	5.2	5.3	5.25
12-Nov-09	3.7	3.8	3.75	6.5	6.6	6.55	7.5	7.1	7.30	4.0	4.1	4.05	6.2	5.9	6.05
14-Nov-09	3.9	4.2	4.05	5.4	5.8	5.60	7.0	6.9	6.95	5.5	5.3	5.40	4.1	4.1	4.10
16-Nov-09	8.2	7.9	8.05	11.3	11.5	11.40	9.3	8.6	8.95	8.3	8.4	8.35	9.3	9.4	9.35

Mid-ebb Date	C7			C8			C9			RC1			RC5		
	Value	Value	Average	Value	Value	Average	Value	Value	Average	Value	Value	Average	Value	Value	Average
21-Oct-09	4.8	4.5	4.65	6.6	6.8	6.70	9.7	9.5	9.60	5.0	4.9	4.95	6.1	6.1	6.10
23-Oct-09	3.8	4.0	3.90	7.0	7.2	7.10	8.6	8.7	8.65	4.7	4.6	4.65	4.2	4.2	4.20
27-Oct-09	5.6	5.6	5.60	7.4	7.4	7.40	8.1	8.0	8.05	5.1	5.3	5.20	5.9	5.9	5.90
29-Oct-09	4.3	4.3	4.30	6.0	6.2	6.10	6.4	6.2	6.30	6.2	6.2	6.20	5.0	4.9	4.95
31-Oct-09	4.0	3.7	3.85	5.3	4.9	5.10	5.6	6.2	5.90	4.4	4.3	4.35	3.9	4.4	4.15
2-Nov-09	2.9	2.6	2.75	6.6	6.0	6.30	6.5	6.5	6.50	4.4	4.3	4.35	4.6	5.6	5.10
4-Nov-09	2.8	2.9	2.85	5.8	5.8	5.80	8.0	7.6	7.80	3.9	4.1	4.00	4.8	4.5	4.65
6-Nov-09	3.4	3.3	3.35	4.5	4.4	4.45	5.2	5.5	5.35	4.3	4.3	4.30	4.9	4.7	4.80
10-Nov-09	4.8	4.3	4.55	5.1	5.1	5.10	5.2	5.2	5.20	4.4	4.3	4.35	3.7	3.8	3.75
12-Nov-09	2.7	2.6	2.65	6.3	6.7	6.50	5.9	5.9	5.90	2.5	2.5	2.50	3.7	4.0	3.85
14-Nov-09	3.6	3.6	3.60	5.6	5.8	5.70	5.8	6.1	5.95	4.3	4.2	4.25	4.5	4.4	4.45
16-Nov-09	8.2	7.9	8.05	9.9	9.9	9.90	8.1	8.5	8.30	9.7	9.4	9.55	8.4	8.4	8.40

Baseline Turbidity Monitoring Data (Oct - Nov 2009)

Mid-flood	RC7		
Date	Value	Value	Average
21-Oct-09	4.9	4.9	4.90
23-Oct-09	4.0	4.1	4.05
27-Oct-09	7.7	7.5	7.60
29-Oct-09	5.5	5.3	5.40
31-Oct-09	4.8	4.8	4.80
2-Nov-09	4.3	4.1	4.20
4-Nov-09	5.0	5.1	5.05
6-Nov-09	5.2	5.4	5.30
10-Nov-09	4.6	4.5	4.55
12-Nov-09	3.4	3.3	3.35
14-Nov-09	3.4	3.1	3.25
16-Nov-09	8.9	8.7	8.80

Mid-ebb	RC7		
Date	Value	Value	Average
21-Oct-09	5.5	5.7	5.60
23-Oct-09	4.4	4.3	4.35
27-Oct-09	9.3	8.0	8.65
29-Oct-09	5.0	4.5	4.75
31-Oct-09	4.3	4.2	4.25
2-Nov-09	4.5	4.2	4.35
4-Nov-09	5.4	4.9	5.15
6-Nov-09	4.9	4.5	4.70
10-Nov-09	6.1	6.8	6.45
12-Nov-09	3.5	3.5	3.50
14-Nov-09	4.2	4.4	4.30
16-Nov-09	8.9	8.9	8.90

Projected Turbidity Monitoring Data (Wet Season) adjusted with Mean Variation Percentage of EPD Marine Monitoring Data (2006 - 2008)

Mid-flood	WSD7		WSD9		WSD10		WSD15		WSD17		WSD19		WSD20		WSD21	
Date	Value	Average	Value	Average	Value	Average	Value	Average	Value	Average	Value	Average	Value	Average	Value	Average
21-Oct-09	10.5	10.04	5.7	5.70	6.4	5.98	9.2	8.78	8.0	8.10	6.4	6.18	6.4	6.65	10.6	10.70
	9.6		5.7		5.5		8.4		8.2		6.0		6.9		10.8	
23-Oct-09	5.0	5.51	4.2	4.65	4.0	4.05	10.1	10.23	6.4	6.75	8.6	8.31	6.0	6.05	8.4	8.55
	6.0		5.1		4.1		10.3		7.1		8.0		6.1		8.7	
27-Oct-09	7.8	7.72	5.0	5.08	4.2	4.18	10.1	9.66	8.5	8.55	8.5	8.31	4.1	3.98	10.0	9.81
	7.6		5.2		4.1		9.2		8.6		8.1		3.8		9.6	
29-Oct-09	8.2	8.24	4.7	4.71	6.4	6.43	4.8	4.83	4.6	4.63	5.3	5.29	3.3	3.22	7.3	7.54
	8.2		4.7		6.4		4.8		4.6		5.3		3.2		7.7	
31-Oct-09	6.5	6.02	2.7	2.60	6.3	7.07	9.0	7.89	7.6	7.59	6.9	7.75	4.4	4.09	6.2	6.27
	5.6		2.5		7.8		6.8		7.6		8.6		3.8		6.3	
2-Nov-09	6.0	5.56	4.6	4.65	4.2	3.99	8.1	7.89	6.3	6.24	6.6	6.03	5.6	5.29	6.3	6.02
	5.1		4.7		3.7		7.7		6.2		5.4		5.0		5.7	
4-Nov-09	7.3	7.16	4.7	4.65	6.0	5.92	8.2	8.54	6.2	6.04	4.9	4.98	6.9	7.09	8.4	8.36
	7.0		4.6		5.8		8.9		5.9		5.0		7.3		8.4	
6-Nov-09	8.6	8.49	4.6	4.53	3.9	3.86	5.6	5.56	5.3	5.53	6.4	6.46	6.0	6.11	8.0	7.98
	8.3		4.5		3.9		5.5		5.8		6.5		6.2		8.0	
10-Nov-09	6.5	6.33	4.6	4.40	4.6	4.82	4.7	4.43	7.5	7.72	9.1	9.35	4.4	4.53	8.5	8.67
	6.2		4.2		5.0		4.2		8.0		9.6		4.7		8.9	
12-Nov-09	10.1	9.78	5.5	5.39	9.1	8.75	9.0	8.94	7.7	7.85	11.8	11.57	7.1	7.31	7.3	7.22
	9.5		5.3		8.4		8.9		8.0		11.3		7.5		7.1	
14-Nov-09	2.0	1.90	2.6	2.79	6.3	6.43	3.7	3.62	8.5	8.17	6.3	6.34	6.0	5.78	6.1	6.33
	1.9		3.0		6.6		3.5		7.8		6.4		5.6		6.6	
16-Nov-09	2.0	1.90	2.9	2.85	3.3	3.41	3.9	3.78	3.1	3.09	2.2	2.09	1.9	1.85	10.6	10.95
	1.9		2.9		3.5		3.7		3.1		2.0		1.9		11.3	

Mid-Ebb	WSD7		WSD9		WSD10		WSD15		WSD17		WSD19		WSD20		WSD21	
Date	Value	Average	Value	Average	Value	Average	Value	Average	Value	Average	Value	Average	Value	Average	Value	Average
21-Oct-09	5.7	5.66	7.8	8.18	6.7	6.43	11.8	11.92	10.0	9.84	10.8	10.58	7.3	7.20	7.9	7.85
	5.7		8.6		6.2		12.1		9.6		10.3		7.1		7.9	
23-Oct-09	6.4	6.13	5.3	5.64	5.5	5.27	5.0	4.91	6.9	6.30	6.5	6.15	4.6	4.58	7.0	7.16
	5.9		6.0		5.0		4.8		5.7		5.8		4.6		7.3	
27-Oct-09	6.9	6.64	2.9	2.98	4.8	4.63	5.2	5.31	4.4	4.44	4.6	4.31	3.4	3.44	7.6	7.60
	6.4		3.1		4.5		5.5		4.5		4.1		3.5		7.6	
29-Oct-09	4.4	4.38	4.1	4.22	6.3	6.30	5.3	5.48	5.9	5.92	6.2	6.09	3.2	3.11	6.2	6.33
	4.3		4.3		6.3		5.6		5.9		6.0		3.1		6.5	
31-Oct-09	3.8	4.02	4.2	4.40	7.8	8.04	6.1	4.59	5.0	4.76	4.7	4.74	5.1	5.78	5.7	5.57
	4.2		4.6		8.2		3.1		4.5		4.8		6.4		5.4	
2-Nov-09	6.5	6.28	4.5	4.53	4.6	4.69	5.8	5.88	5.9	5.34	6.0	6.34	3.8	3.82	6.1	6.02
	6.1		4.6		4.8		6.0		4.8		6.6		3.8		6.0	
4-Nov-09	3.3	3.35	3.6	3.47	3.5	3.54	9.8	9.58	4.5	4.44	3.9	4.06	4.1	4.04	7.6	7.41
	3.4		3.3		3.6		9.3		4.4		4.2		3.9		7.2	
6-Nov-09	3.9	3.86	3.8	3.72	4.2	4.12	9.2	9.10	5.9	5.79	8.6	8.18	5.8	5.56	7.0	6.84
	3.8		3.6		4.0		9.0		5.7		7.8		5.3		6.7	
10-Nov-09	3.9	3.86	6.4	6.51	3.5	3.54	3.9	3.78	5.3	5.40	5.2	5.29	3.3	3.38	5.6	5.64
	3.8		6.6		3.6		3.7		5.5		5.4		3.5		5.7	
12-Nov-09	5.3	5.25	5.5	5.52	7.8	7.85	8.9	9.02	9.4	9.58	4.9	5.05	3.8	3.87	6.0	5.76
	5.3		5.6		7.8		9.2		9.8		5.2		3.9		5.6	
14-Nov-09	2.3	2.16	3.0	2.98	5.7	5.40	2.6	2.42	3.7	3.86	2.6	2.65	2.6	2.45	6.5	6.40
	2.1		3.0		5.1		2.3		4.0		2.7		2.3		6.3	
16-Nov-09	2.2	2.16	3.0	2.91	3.6	3.54	4.7	4.51	3.6	3.41	3.1	3.14	2.1	2.07	10.9	10.83
	2.2		2.9		3.5		4.3		3.2		3.2		2.1		10.8	

Projected Turbidity Monitoring Data (Wet Season) adjusted with Mean Variation Percentage of EPD Marine Monitoring Data (2006 - 2008)

Mid-flood Date	RW21		C1		C2		C3		C4		C5		C6		C7	
	Value	Average	Value	Average	Value	Average	Value	Average	Value	Average	Value	Average	Value	Average	Value	Average
21-Oct-09	13.2	13.30	7.7	7.85	7.2	7.09	10.8	10.32	8.6	9.12	9.6	9.42	6.8	6.84	7.3	7.16
	13.4		8.0		7.0		9.9		9.6		9.3		6.8		7.0	
23-Oct-09	10.4	10.32	7.6	7.22	7.0	7.03	7.7	7.66	9.1	9.12	8.5	8.36	7.3	7.28	8.6	8.42
	10.3		6.8		7.1		7.6		9.1		8.2		7.2		8.2	
27-Oct-09	9.9	9.81	6.5	6.52	9.9	10.07	9.9	9.69	8.9	8.86	9.2	9.18	9.4	9.31	7.0	6.97
	9.8		6.6		10.3		9.5		8.9		9.1		9.2		7.0	
29-Oct-09	8.1	7.92	6.2	6.21	7.9	7.92	9.4	8.74	11.8	11.14	9.4	9.43	8.0	7.60	9.8	9.50
	7.7		6.2		8.0		8.1		10.5		9.5		7.2		9.2	
31-Oct-09	6.0	6.65	5.2	5.45	8.4	8.11	6.0	6.02	6.5	6.71	6.0	5.95	5.2	5.13	6.1	5.95
	7.3		5.7		7.9		6.1		7.0		6.0		5.1		5.8	
2-Nov-09	5.4	5.26	7.6	7.47	4.7	4.62	4.2	4.12	4.2	4.12	4.6	4.31	7.1	7.22	6.0	5.89
	5.1		7.3		4.6		4.1		4.1		4.1		7.3		5.8	
4-Nov-09	7.1	6.97	5.1	5.00	6.6	6.33	7.9	8.04	7.5	7.35	7.5	7.28	6.1	5.89	6.2	6.27
	6.8		4.9		6.1		8.2		7.2		7.1		5.7		6.3	
6-Nov-09	8.2	8.11	4.6	4.62	7.9	7.73	6.0	5.83	8.1	7.92	8.1	8.04	4.1	4.12	5.7	5.64
	8.0		4.7		7.6		5.7		7.7		8.0		4.2		5.6	
10-Nov-09	6.1	6.40	5.1	4.94	7.3	7.41	7.2	7.35	8.6	8.42	8.4	8.55	6.7	6.59	6.1	6.02
	6.7		4.8		7.5		7.5		8.2		8.7		6.5		6.0	
12-Nov-09	6.0	5.83	4.1	3.99	5.8	5.70	6.1	5.95	6.8	6.97	6.7	6.84	4.6	4.62	4.7	4.75
	5.7		3.9		5.6		5.8		7.1		7.0		4.7		4.8	
14-Nov-09	7.7	7.54	5.1	4.88	7.5	7.28	4.8	4.88	5.8	5.89	6.2	6.27	5.7	5.57	4.9	5.13
	7.3		4.7		7.1		4.9		6.0		6.3		5.4		5.3	
16-Nov-09	10.0	10.00	10.6	10.95	11.4	11.14	10.5	10.45	11.9	11.71	11.5	11.21	10.1	9.94	10.4	10.19
	10.0		11.3		10.9		10.4		11.5		10.9		9.8		10.0	

Mid-Ebb Date	RW21		C1		C2		C3		C4		C5		C6		C7	
	Value	Average	Value	Average	Value	Average	Value	Average	Value	Average	Value	Average	Value	Average	Value	Average
21-Oct-09	8.4	8.36	6.5	6.65	7.7	7.85	6.6	6.65	8.6	8.61	9.8	9.88	7.0	6.78	6.1	5.89
	8.4		6.8		8.0		6.7		8.6		10.0		6.6		5.7	
23-Oct-09	6.2	6.27	7.0	7.16	7.6	7.22	8.9	8.61	6.8	6.84	6.7	6.84	7.1	7.09	4.8	4.94
	6.3		7.3		6.8		8.4		6.8		7.0		7.1		5.1	
27-Oct-09	7.5	7.47	10.6	10.57	6.5	6.52	6.8	6.84	8.4	8.17	8.0	7.92	7.9	7.92	7.1	7.09
	7.5		10.5		6.6		6.8		8.0		7.9		8.0		7.1	
29-Oct-09	6.1	6.08	7.6	7.73	6.2	6.21	6.0	5.89	6.3	6.21	6.5	6.40	6.1	6.08	5.4	5.45
	6.1		7.9		6.2		5.8		6.1		6.3		6.1		5.4	
31-Oct-09	5.8	5.79	6.2	6.08	5.2	5.45	4.8	4.88	5.6	5.32	6.1	6.02	7.3	7.54	5.1	4.88
	5.8		6.0		5.7		4.9		5.1		6.0		7.7		4.7	
2-Nov-09	3.9	3.86	5.7	5.26	7.6	7.47	8.4	8.23	7.7	7.35	5.3	5.26	4.8	4.88	3.7	3.48
	3.8		4.8		7.3		8.1		7.0		5.2		4.9		3.3	
4-Nov-09	6.6	6.55	5.8	5.95	5.1	5.00	7.9	7.73	8.4	8.11	6.2	6.52	6.8	6.59	3.5	3.61
	6.5		6.1		4.9		7.6		7.9		6.8		6.3		3.7	
6-Nov-09	5.3	5.41	6.1	6.02	4.6	4.62	5.7	5.64	5.2	5.32	9.4	9.56	5.1	5.07	4.3	4.24
	5.5		6.0		4.7		5.6		5.4		9.8		5.1		4.2	
10-Nov-09	4.8	4.94	5.8	5.76	5.1	4.94	5.6	5.45	6.5	6.27	5.6	5.57	6.3	6.21	6.1	5.76
	5.1		5.7		4.8		5.3		6.1		5.6		6.1		5.4	
12-Nov-09	5.8	5.76	5.8	5.70	4.1	3.99	3.5	3.48	3.5	3.67	6.2	6.08	5.4	5.45	3.4	3.36
	5.7		5.6		3.9		3.4		3.8		6.0		5.4		3.3	
14-Nov-09	8.1	8.01	5.6	5.38	5.1	4.88	6.0	6.08	6.1	6.02	8.5	8.29	6.7	6.65	4.6	4.56
	7.9		5.2		4.7		6.2		6.0		8.1		6.6		4.6	
16-Nov-09	11.4	11.37	11.7	11.40	10.6	10.95	11.3	11.21	11.1	11.27	11.8	11.84	11.3	11.08	10.4	10.19
	11.3		11.1		11.3		11.1		11.4		11.9		10.9		10.0	

Projected Turbidity Monitoring Data (Wet Season) adjusted with Mean Variation Percentage of EPD Marine Monitoring Data (2006 - 2008)

Mid-flood	C8		C9		RC1		RC5		RC7	
Date	Value	Average	Value	Average	Value	Average	Value	Average	Value	Average
21-Oct-09	11.0	11.10	10.2	10.11	7.2	7.41	8.1	8.11	6.2	6.21
	11.2		10.0		7.6		8.1		6.2	
23-Oct-09	11.7	12.09	12.6	12.65	7.0	6.97	9.5	9.43	5.1	5.13
	12.5		12.6		7.0		9.4		5.2	
27-Oct-09	12.4	12.46	13.5	13.70	10.0	10.07	9.6	9.56	9.8	9.62
	12.5		13.9		10.1		9.5		9.5	
29-Oct-09	10.7	10.91	12.9	13.14	8.2	7.79	8.1	7.92	7.0	6.84
	11.2		13.4		7.3		7.7		6.7	
31-Oct-09	7.2	7.50	12.3	12.28	6.3	6.52	5.1	5.00	6.1	6.08
	7.8		12.3		6.7		4.9		6.1	
2-Nov-09	6.0	5.95	6.3	6.63	4.3	4.18	5.3	5.38	5.4	5.32
	6.0		6.9		4.1		5.4		5.2	
4-Nov-09	8.1	8.00	9.4	9.55	5.4	5.70	7.7	8.04	6.3	6.40
	7.9		9.7		6.0		8.4		6.5	
6-Nov-09	11.5	11.72	10.4	10.17	7.5	7.35	6.6	6.65	6.6	6.71
	11.9		9.9		7.2		6.7		6.8	
10-Nov-09	9.1	9.30	10.4	10.11	6.3	6.27	6.6	6.65	5.8	5.76
	9.5		9.8		6.2		6.7		5.7	
12-Nov-09	8.1	8.12	9.3	9.05	5.1	5.13	7.9	7.66	4.3	4.24
	8.2		8.8		5.2		7.5		4.2	
14-Nov-09	6.7	6.94	8.7	8.62	7.0	6.84	5.2	5.19	4.3	4.12
	7.2		8.6		6.7		5.2		3.9	
16-Nov-09	14.0	14.14	11.5	11.10	10.5	10.57	11.8	11.84	11.3	11.14
	14.3		10.7		10.6		11.9		11.0	

Mid-Ebb	C8		C9		RC1		RC5		RC7	
Date	Value	Average	Value	Average	Value	Average	Value	Average	Value	Average
21-Oct-09	8.2	8.31	12.0	11.90	6.3	6.27	7.7	7.73	7.0	7.09
	8.4		11.8		6.2		7.7		7.2	
23-Oct-09	8.7	8.80	10.7	10.73	6.0	5.89	5.3	5.32	5.6	5.51
	8.9		10.8		5.8		5.3		5.4	
27-Oct-09	9.2	9.18	10.0	9.98	6.5	6.59	7.5	7.47	11.8	10.95
	9.2		9.9		6.7		7.5		10.1	
29-Oct-09	7.4	7.56	7.9	7.81	7.9	7.85	6.3	6.27	6.3	6.02
	7.7		7.7		7.9		6.2		5.7	
31-Oct-09	6.6	6.32	6.9	7.32	5.6	5.51	4.9	5.26	5.4	5.38
	6.1		7.7		5.4		5.6		5.3	
2-Nov-09	8.2	7.81	8.1	8.06	5.6	5.51	5.8	6.46	5.7	5.51
	7.4		8.1		5.4		7.1		5.3	
4-Nov-09	7.2	7.19	9.9	9.67	4.9	5.07	6.1	5.89	6.8	6.52
	7.2		9.4		5.2		5.7		6.2	
6-Nov-09	5.6	5.52	6.4	6.63	5.4	5.45	6.2	6.08	6.2	5.95
	5.5		6.8		5.4		6.0		5.7	
10-Nov-09	6.3	6.32	6.4	6.45	5.6	5.51	4.7	4.75	7.7	8.17
	6.3		6.4		5.4		4.8		8.6	
12-Nov-09	7.8	8.06	7.3	7.32	3.2	3.17	4.7	4.88	4.4	4.43
	8.3		7.3		3.2		5.1		4.4	
14-Nov-09	6.9	7.07	7.2	7.38	5.4	5.38	5.7	5.64	5.3	5.45
	7.2		7.6		5.3		5.6		5.6	
16-Nov-09	12.3	12.28	10.0	10.29	12.3	12.09	10.6	10.64	11.3	11.27
	12.3		10.5		11.9		10.6		11.3	

Baseline DO Monitoring Data (Oct - Nov 2009)

Mid-flood Date	WSD7			WSD9			WSD10			WSD15			WSD17		
	Value	Value	Average	Value	Value	Average	Value	Value	Average	Value	Value	Average	Value	Value	Average
21-Oct-09	4.40	4.40	4.40	4.70	4.82	4.76	5.14	5.10	5.12	5.14	5.17	5.16	5.38	5.20	5.29
23-Oct-09	4.91	4.38	4.65	4.27	4.40	4.34	4.51	4.47	4.49	4.68	4.60	4.64	4.88	4.86	4.87
27-Oct-09	4.20	4.23	4.22	4.96	4.91	4.94	4.68	4.65	4.67	4.44	4.38	4.41	4.92	4.66	4.79
29-Oct-09	4.76	4.63	4.70	4.90	4.89	4.90	6.07	6.01	6.04	4.48	4.37	4.43	4.60	4.52	4.56
31-Oct-09	4.51	4.62	4.57	5.10	5.04	5.07	4.93	4.86	4.90	4.88	4.79	4.84	4.75	4.80	4.78
2-Nov-09	5.14	5.16	5.15	5.26	5.31	5.29	5.42	5.55	5.49	5.68	5.70	5.69	5.85	5.34	5.60
4-Nov-09	6.23	6.12	6.18	6.44	6.34	6.39	6.48	6.46	6.47	6.59	6.45	6.52	6.53	6.62	6.58
6-Nov-09	5.50	5.43	5.47	5.34	5.30	5.32	5.59	5.58	5.59	5.63	5.65	5.64	5.63	5.61	5.62
10-Nov-09	5.18	5.17	5.18	4.67	4.61	4.64	5.13	5.08	5.11	4.89	4.91	4.90	5.21	5.12	5.17
12-Nov-09	3.38	3.63	3.51	3.32	3.41	3.37	3.49	3.68	3.59	3.30	3.63	3.47	3.91	4.06	3.99
14-Nov-09	6.82	6.76	6.79	8.25	8.33	8.29	7.98	8.32	8.15	8.52	8.62	8.57	8.40	8.43	8.42
16-Nov-09	7.45	7.38	7.42	8.58	8.55	8.57	7.48	7.47	7.48	7.43	7.42	7.43	8.90	8.29	8.60

Mid-ebb Date	WSD7			WSD9			WSD10			WSD15			WSD17		
	Value	Value	Average	Value	Value	Average	Value	Value	Average	Value	Value	Average	Value	Value	Average
21-Oct-09	4.89	4.83	4.86	4.78	4.78	4.78	5.09	5.03	5.06	4.93	4.88	4.91	4.99	4.67	4.83
23-Oct-09	4.07	3.88	3.98	4.44	4.36	4.40	5.56	5.38	5.47	4.65	4.62	4.64	4.33	4.16	4.25
27-Oct-09	4.79	4.57	4.68	4.70	4.64	4.67	4.58	4.66	4.62	4.28	4.23	4.26	5.02	4.72	4.87
29-Oct-09	5.37	5.37	5.37	5.39	5.17	5.28	5.06	4.97	5.02	4.87	4.79	4.83	4.31	4.24	4.28
31-Oct-09	4.50	4.42	4.46	5.22	5.13	5.18	5.83	5.88	5.86	5.14	5.22	5.18	5.07	5.27	5.17
2-Nov-09	5.13	5.06	5.10	5.28	5.21	5.25	5.18	5.14	5.16	4.45	4.32	4.39	4.22	4.29	4.26
4-Nov-09	6.14	6.12	6.13	6.20	6.19	6.20	6.29	6.27	6.28	6.40	6.46	6.43	6.20	6.16	6.18
6-Nov-09	5.31	5.31	5.31	5.66	5.65	5.66	5.79	5.73	5.76	5.75	5.74	5.75	5.55	5.61	5.58
10-Nov-09	6.03	5.97	6.00	5.49	5.38	5.44	4.36	4.29	4.33	4.67	4.64	4.66	5.35	5.41	5.38
12-Nov-09	4.84	4.81	4.83	3.59	3.71	3.65	4.70	4.69	4.70	2.81	3.04	2.93	3.13	3.40	3.27
14-Nov-09	7.12	7.16	7.14	8.57	8.58	8.58	8.57	8.43	8.50	8.54	8.57	8.56	8.45	8.41	8.43
16-Nov-09	7.85	7.72	7.79	8.77	8.76	8.77	6.66	6.61	6.64	6.87	6.80	6.84	7.18	7.09	7.14

Baseline DO Monitoring Data (Oct - Nov 2009)

Mid-flood	WSD19			WSD20			WSD21			RW1			C1		
Date	Value	Value	Average	Value	Value	Average	Value	Value	Average	Value	Value	Average	Value	Value	Average
21-Oct-09	4.36	4.45	4.41	5.31	4.78	5.05	4.49	4.49	4.49	4.74	4.66	4.70	4.75	4.52	4.64
23-Oct-09	3.71	3.60	3.66	4.78	4.58	4.68	3.92	3.86	3.89	4.35	4.35	4.35	4.62	4.48	4.55
27-Oct-09	3.94	3.83	3.89	3.82	3.88	3.85	4.45	4.34	4.40	4.35	4.32	4.34	4.64	4.64	4.64
29-Oct-09	4.99	4.92	4.96	4.59	4.55	4.57	4.66	4.61	4.64	4.75	4.71	4.73	4.84	4.82	4.83
31-Oct-09	4.33	4.31	4.32	4.04	4.11	4.08	4.89	4.87	4.88	5.22	5.20	5.21	4.82	4.81	4.82
2-Nov-09	5.57	5.40	5.49	5.30	5.35	5.33	4.90	4.55	4.73	5.28	4.66	4.97	4.80	4.78	4.79
4-Nov-09	6.38	6.31	6.35	6.48	6.41	6.45	4.82	4.76	4.79	4.79	4.96	4.88	4.53	4.60	4.57
6-Nov-09	5.17	5.11	5.14	5.79	5.78	5.79	4.73	4.67	4.70	4.56	4.55	4.56	4.69	4.61	4.65
10-Nov-09	5.54	5.52	5.53	5.38	5.32	5.35	4.50	4.45	4.48	4.59	4.55	4.57	4.68	4.66	4.67
12-Nov-09	3.30	3.42	3.36	3.18	3.51	3.35	3.93	3.86	3.90	4.11	4.05	4.08	3.69	3.64	3.67
14-Nov-09	8.03	7.74	7.89	7.98	7.99	7.99	3.53	3.48	3.51	4.32	4.13	4.23	4.43	4.47	4.45
16-Nov-09	7.36	7.19	7.28	8.55	8.50	8.53	4.66	4.32	4.49	4.58	4.47	4.53	5.33	5.43	5.38

Mid-ebb	WSD19			WSD20			WSD21			RW1			C1		
Date	Value	Value	Average	Value	Value	Average	Value	Value	Average	Value	Value	Average	Value	Value	Average
21-Oct-09	4.70	4.93	4.82	4.80	4.80	4.80	4.84	4.84	4.84	4.56	4.48	4.52	4.55	4.44	4.50
23-Oct-09	4.04	4.25	4.15	4.52	4.48	4.50	3.67	3.65	3.66	4.93	4.55	4.74	4.38	4.38	4.38
27-Oct-09	4.92	4.99	4.96	4.92	5.05	4.99	4.60	4.41	4.51	4.66	4.46	4.56	4.81	4.64	4.73
29-Oct-09	4.71	4.63	4.67	5.10	5.02	5.06	4.81	4.71	4.76	4.83	4.78	4.81	4.66	4.54	4.60
31-Oct-09	4.07	4.14	4.11	4.69	4.43	4.56	5.22	4.98	5.10	5.06	4.86	4.96	5.20	5.17	5.19
2-Nov-09	4.28	4.43	4.36	4.86	4.94	4.90	4.90	4.79	4.85	5.50	5.62	5.56	4.99	4.82	4.91
4-Nov-09	6.58	6.55	6.57	6.66	6.53	6.60	4.52	4.44	4.48	4.63	4.52	4.58	5.65	5.60	5.63
6-Nov-09	5.78	5.76	5.77	5.93	5.92	5.93	3.96	3.90	3.93	4.01	3.99	4.00	4.79	4.75	4.77
10-Nov-09	5.95	5.93	5.94	5.74	5.67	5.71	4.65	4.55	4.60	4.67	4.62	4.65	4.50	4.38	4.44
12-Nov-09	2.96	3.02	2.99	3.67	3.76	3.72	3.75	3.73	3.74	3.85	3.78	3.82	3.96	3.91	3.94
14-Nov-09	8.39	8.23	8.31	7.91	7.84	7.88	4.62	4.52	4.57	4.63	4.57	4.60	4.55	4.32	4.44
16-Nov-09	8.33	8.20	8.27	8.76	8.70	8.73	6.67	6.49	6.58	6.33	6.22	6.28	4.02	4.05	4.04

Baseline DO Monitoring Data (Oct - Nov 2009)

Mid-flood	C2			C3			C4			C5			C6		
Date	Value	Value	Average	Value	Value	Average	Value	Value	Average	Value	Value	Average	Value	Value	Average
21-Oct-09	4.52	4.46	4.49	4.46	4.39	4.43	4.46	4.29	4.38	4.55	4.48	4.52	3.51	3.44	3.48
23-Oct-09	4.23	3.96	4.10	4.22	4.09	4.16	4.22	4.01	4.12	4.88	4.32	4.60	2.83	2.63	2.73
27-Oct-09	4.39	4.25	4.32	4.42	4.36	4.39	4.55	4.45	4.50	4.46	4.36	4.41	3.56	3.29	3.43
29-Oct-09	4.69	4.60	4.65	4.60	4.61	4.61	4.58	4.51	4.55	4.70	4.60	4.65	3.73	3.29	3.51
31-Oct-09	4.87	4.83	4.85	5.05	5.02	5.04	5.12	4.99	5.06	5.03	4.92	4.98	4.03	3.92	3.98
2-Nov-09	4.69	4.59	4.64	5.07	4.85	4.96	4.71	4.66	4.69	5.31	4.65	4.98	3.85	3.76	3.81
4-Nov-09	5.36	5.01	5.19	5.34	5.31	5.33	5.24	5.20	5.22	4.83	4.73	4.78	3.85	3.74	3.80
6-Nov-09	4.70	4.60	4.65	4.61	4.58	4.60	4.58	4.54	4.56	4.74	4.66	4.70	3.46	3.34	3.40
10-Nov-09	4.53	4.44	4.49	4.44	4.45	4.45	4.42	4.35	4.39	4.54	4.44	4.49	3.57	3.13	3.35
12-Nov-09	3.84	3.78	3.81	3.97	3.95	3.96	3.87	3.81	3.84	3.87	3.81	3.84	2.76	2.70	2.73
14-Nov-09	4.47	4.44	4.46	4.27	4.18	4.23	3.97	3.95	3.96	3.81	3.67	3.74	3.16	3.19	3.18
16-Nov-09	3.99	3.91	3.95	4.32	4.25	4.29	4.34	4.26	4.30	4.43	4.33	4.38	3.15	3.20	3.18

Mid-ebb	C2			C3			C4			C5			C6		
Date	Value	Value	Average	Value	Value	Average	Value	Value	Average	Value	Value	Average	Value	Value	Average
21-Oct-09	4.47	4.47	4.47	4.73	4.64	4.69	4.84	4.83	4.84	4.26	4.26	4.26	3.74	3.71	3.73
23-Oct-09	4.03	3.95	3.99	4.08	4.00	4.04	3.99	3.91	3.95	4.07	3.94	4.01	3.68	3.35	3.52
27-Oct-09	4.75	4.59	4.67	4.53	4.42	4.48	4.58	4.44	4.51	4.31	4.18	4.25	4.29	3.85	4.07
29-Oct-09	5.02	4.97	5.00	4.98	4.84	4.91	4.77	4.76	4.77	4.84	4.79	4.82	3.08	2.98	3.03
31-Oct-09	5.11	5.01	5.06	4.77	4.75	4.76	4.79	4.75	4.77	5.06	4.81	4.94	4.49	3.43	3.96
2-Nov-09	5.16	5.01	5.09	4.74	4.73	4.74	4.84	4.80	4.82	5.19	5.02	5.11	4.46	4.28	4.37
4-Nov-09	5.03	5.01	5.02	4.79	4.79	4.79	4.69	4.61	4.65	4.93	4.58	4.76	4.47	4.28	4.38
6-Nov-09	4.41	4.33	4.37	4.35	4.30	4.33	4.09	4.05	4.07	3.98	3.96	3.97	3.80	3.76	3.78
10-Nov-09	4.86	4.81	4.84	4.82	4.68	4.75	4.61	4.60	4.61	4.68	4.63	4.66	2.92	2.82	2.87
12-Nov-09	3.86	3.83	3.85	4.07	4.00	4.04	3.88	3.83	3.86	3.99	3.92	3.96	2.81	2.77	2.79
14-Nov-09	4.59	4.68	4.64	4.60	4.55	4.58	4.56	4.48	4.52	4.76	4.75	4.76	3.89	3.80	3.85
16-Nov-09	5.75	5.54	5.65	6.22	6.09	6.16	5.58	5.37	5.48	6.11	6.11	6.11	5.64	5.21	5.43

Baseline DO Monitoring Data (Oct - Nov 2009)

Mid-flood	C7			C8			C9			RC1			RC5		
Date	Value	Value	Average	Value	Value	Average	Value	Value	Average	Value	Value	Average	Value	Value	Average
21-Oct-09	4.07	3.91	3.99	4.96	4.96	4.96	4.93	4.78	4.86	4.15	4.15	4.15	4.54	4.55	4.55
23-Oct-09	3.51	3.38	3.45	4.19	4.07	4.13	3.83	3.81	3.82	4.18	4.18	4.18	3.94	3.92	3.93
27-Oct-09	3.76	3.35	3.56	3.90	3.63	3.77	4.22	3.46	3.84	4.42	4.30	4.36	4.52	4.48	4.50
29-Oct-09	4.23	4.09	4.16	4.16	4.04	4.10	3.55	3.45	3.50	4.65	4.62	4.64	4.74	4.72	4.73
31-Oct-09	4.27	4.19	4.23	4.63	4.53	4.58	4.05	3.99	4.02	5.00	4.93	4.97	5.28	5.32	5.30
2-Nov-09	4.32	3.60	3.96	4.03	3.90	3.97	4.90	4.45	4.68	4.53	4.49	4.51	4.42	4.34	4.38
4-Nov-09	3.89	3.82	3.86	4.36	4.32	4.34	4.58	4.47	4.53	5.80	5.77	5.79	4.80	4.76	4.78
6-Nov-09	3.89	3.78	3.84	4.43	4.42	4.43	4.66	4.59	4.63	4.52	4.46	4.49	4.76	4.66	4.71
10-Nov-09	4.07	3.93	4.00	4.00	3.88	3.94	3.39	3.29	3.34	4.49	4.46	4.48	4.58	4.56	4.57
12-Nov-09	2.87	2.82	2.85	3.98	3.94	3.96	3.99	3.92	3.96	3.90	3.82	3.86	3.89	3.85	3.87
14-Nov-09	3.09	3.12	3.11	4.65	4.57	4.61	4.51	4.48	4.50	4.77	4.75	4.76	3.96	3.91	3.94
16-Nov-09	3.97	3.65	3.81	6.37	6.33	6.35	6.33	6.13	6.23	3.62	3.68	3.65	4.32	4.35	4.34

Mid-ebb	C7			C8			C9			RC1			RC5		
Date	Value	Value	Average	Value	Value	Average	Value	Value	Average	Value	Value	Average	Value	Value	Average
21-Oct-09	3.67	3.65	3.66	4.96	4.78	4.87	5.01	5.13	5.07	4.51	4.43	4.47	4.73	4.61	4.67
23-Oct-09	3.79	3.52	3.66	4.64	4.54	4.59	5.43	4.50	4.97	3.91	3.86	3.89	4.05	4.05	4.05
27-Oct-09	3.69	3.71	3.70	4.44	4.44	4.44	4.64	4.45	4.55	4.18	4.06	4.12	4.21	4.16	4.19
29-Oct-09	3.58	3.53	3.56	4.41	4.40	4.41	4.78	4.64	4.71	4.74	4.74	4.74	4.83	4.73	4.78
31-Oct-09	4.09	3.88	3.99	4.73	4.71	4.72	4.88	4.75	4.82	4.58	4.60	4.59	4.92	4.76	4.84
2-Nov-09	4.80	4.56	4.68	4.95	4.90	4.93	3.89	4.03	3.96	4.79	4.70	4.75	5.64	5.58	5.61
4-Nov-09	4.92	4.65	4.79	5.76	5.74	5.75	5.69	5.65	5.67	4.71	4.63	4.67	4.61	4.62	4.62
6-Nov-09	3.98	3.96	3.97	5.42	5.36	5.39	5.31	5.21	5.26	4.18	4.16	4.17	4.13	4.04	4.09
10-Nov-09	3.42	3.37	3.40	4.25	4.24	4.25	4.62	4.48	4.55	4.58	4.58	4.58	4.67	4.57	4.62
12-Nov-09	3.01	2.98	3.00	4.11	4.03	4.07	3.94	3.87	3.91	3.98	3.90	3.94	3.79	3.77	3.78
14-Nov-09	3.94	3.92	3.93	4.39	4.47	4.43	4.54	4.58	4.56	4.61	4.59	4.60	4.58	4.63	4.61
16-Nov-09	5.15	5.12	5.14	6.39	6.33	6.36	5.93	5.89	5.91	5.86	5.93	5.90	6.91	6.66	6.79

Baseline DO Monitoring Data (Oct - Nov 2009)

Mid-flood	RC7		
Date	Value	Value	Average
21-Oct-09	3.53	3.53	3.53
23-Oct-09	3.57	3.17	3.37
27-Oct-09	5.06	3.67	4.37
29-Oct-09	4.16	4.02	4.09
31-Oct-09	4.27	4.14	4.21
2-Nov-09	4.04	3.73	3.89
4-Nov-09	3.88	3.66	3.77
6-Nov-09	3.60	3.51	3.56
10-Nov-09	4.00	3.86	3.93
12-Nov-09	1.71	1.67	1.69
14-Nov-09	2.16	2.12	2.14
16-Nov-09	4.32	4.32	4.32

Mid-ebb	RC7		
Date	Value	Value	Average
21-Oct-09	3.69	3.71	3.70
23-Oct-09	4.17	3.81	3.99
27-Oct-09	4.57	4.07	4.32
29-Oct-09	4.09	3.67	3.88
31-Oct-09	4.16	4.00	4.08
2-Nov-09	4.78	4.54	4.66
4-Nov-09	5.04	4.91	4.98
6-Nov-09	3.94	3.88	3.91
10-Nov-09	3.93	3.51	3.72
12-Nov-09	2.73	2.70	2.72
14-Nov-09	3.58	3.62	3.60
16-Nov-09	5.53	5.53	5.53

Projected DO Monitoring Data (Wet Season) adjusted with Mean Variation Percentage of EPD Marine Monitoring Data (2006 - 2008)

Mid-flood	WSD7		WSD9		WSD10		WSD15		WSD17		WSD19		WSD20		WSD21	
Date	Value	Average	Value	Average	Value	Average	Value	Average	Value	Average	Value	Average	Value	Average	Value	Average
21-Oct-09	4.01	4.01	4.26	4.31	4.50	4.48	3.80	3.81	4.71	4.63	3.97	4.01	4.53	4.30	4.01	4.01
	4.01		4.37		4.47		3.82		4.55		4.05		4.07		4.01	
23-Oct-09	4.47	4.23	3.87	3.93	3.95	3.93	3.46	3.43	4.27	4.27	3.22	3.17	4.07	3.99	3.51	3.48
	3.99		3.99		3.91		3.40		4.26		3.13		3.90		3.45	
27-Oct-09	3.82	3.84	4.50	4.47	4.10	4.09	3.28	3.26	4.31	4.19	3.42	3.37	3.26	3.28	3.98	3.93
	3.85		4.45		4.07		3.23		4.08		3.33		3.31		3.88	
29-Oct-09	4.33	4.27	4.44	4.44	5.32	5.29	3.31	3.27	4.03	3.99	4.33	4.30	3.91	3.89	4.17	4.14
	4.21		4.43		5.26		3.23		3.96		4.27		3.88		4.12	
31-Oct-09	4.11	4.16	4.62	4.60	4.32	4.29	3.60	3.57	4.16	4.18	3.76	3.75	3.44	3.47	4.37	4.36
	4.21		4.57		4.26		3.54		4.20		3.74		3.50		4.35	
2-Nov-09	4.68	4.69	4.77	4.79	4.75	4.80	4.19	4.20	5.12	4.90	4.84	4.76	4.52	4.54	4.38	4.22
	4.70		4.81		4.86		4.21		4.68		4.69		4.56		4.07	
4-Nov-09	5.67	5.62	5.84	5.79	5.68	5.67	4.87	4.81	5.72	5.76	5.54	5.51	5.52	5.49	4.31	4.28
	5.57		5.75		5.66		4.76		5.80		5.48		5.46		4.26	
6-Nov-09	5.01	4.97	4.84	4.82	4.90	4.89	4.16	4.16	4.93	4.92	4.49	4.46	4.93	4.93	4.23	4.20
	4.94		4.80		4.89		4.17		4.91		4.44		4.93		4.18	
10-Nov-09	4.72	4.71	4.23	4.21	4.49	4.47	3.61	3.62	4.56	4.52	4.81	4.80	4.59	4.56	4.02	4.00
	4.71		4.18		4.45		3.63		4.48		4.79		4.53		3.98	
12-Nov-09	3.08	3.19	3.01	3.05	3.06	3.14	2.44	2.56	3.42	3.49	2.87	2.92	2.71	2.85	3.51	3.48
	3.30		3.09		3.22		2.68		3.56		2.97		2.99		3.45	
14-Nov-09	6.21	6.18	7.48	7.51	6.99	7.14	6.29	6.33	7.36	7.37	6.97	6.85	6.80	6.81	3.16	3.13
	6.15		7.55		7.29		6.37		7.38		6.72		6.81		3.11	
16-Nov-09	6.78	6.75	7.78	7.76	6.55	6.55	5.49	5.48	7.79	7.53	6.39	6.32	7.29	7.27	4.17	4.01
	6.72		7.75		6.54		5.48		7.26		6.24		7.24		3.86	

Mid-Ebb	WSD7		WSD9		WSD10		WSD15		WSD17		WSD19		WSD20		WSD21	
Date	Value	Average	Value	Average	Value	Average	Value	Average	Value	Average	Value	Average	Value	Average	Value	Average
21-Oct-09	4.45	4.42	4.33	4.33	4.46	4.43	3.64	3.62	4.37	4.23	4.08	4.18	4.09	4.09	4.33	4.33
	4.40		4.33		4.41		3.60		4.09		4.28		4.09		4.33	
23-Oct-09	3.70	3.62	4.02	3.99	4.87	4.79	3.43	3.42	3.79	3.72	3.51	3.60	3.85	3.84	3.28	3.27
	3.53		3.95		4.71		3.41		3.64		3.69		3.82		3.26	
27-Oct-09	4.36	4.26	4.26	4.23	4.01	4.05	3.16	3.14	4.40	4.27	4.27	4.30	4.19	4.25	4.11	4.03
	4.16		4.21		4.08		3.12		4.13		4.33		4.30		3.94	
29-Oct-09	4.89	4.89	4.89	4.79	4.43	4.39	3.60	3.57	3.77	3.74	4.09	4.06	4.35	4.31	4.30	4.26
	4.89		4.69		4.35		3.54		3.71		4.02		4.28		4.21	
31-Oct-09	4.10	4.06	4.73	4.69	5.11	5.13	3.80	3.83	4.44	4.53	3.53	3.57	4.00	3.89	4.67	4.56
	4.02		4.65		5.15		3.85		4.62		3.60		3.78		4.45	
2-Nov-09	4.67	4.64	4.79	4.75	4.54	4.52	3.29	3.24	3.70	3.73	3.72	3.78	4.14	4.18	4.38	4.33
	4.61		4.72		4.50		3.19		3.76		3.85		4.21		4.28	
4-Nov-09	5.59	5.58	5.62	5.62	5.51	5.50	4.73	4.75	5.43	5.41	5.71	5.70	5.68	5.62	4.04	4.01
	5.57		5.61		5.49		4.77		5.39		5.69		5.57		3.97	
6-Nov-09	4.83	4.83	5.13	5.13	5.07	5.04	4.25	4.24	4.86	4.89	5.02	5.01	5.05	5.05	3.54	3.51
	4.83		5.12		5.02		4.24		4.91		5.00		5.05		3.49	
10-Nov-09	5.49	5.46	4.98	4.93	3.82	3.79	3.45	3.44	4.69	4.71	5.17	5.16	4.89	4.86	4.16	4.11
	5.43		4.88		3.76		3.43		4.74		5.15		4.83		4.07	
12-Nov-09	4.41	4.39	3.25	3.31	4.12	4.11	2.07	2.16	2.74	2.86	2.57	2.60	3.13	3.17	3.35	3.34
	4.38		3.36		4.11		2.24		2.98		2.62		3.20		3.34	
14-Nov-09	6.48	6.50	7.77	7.77	7.51	7.44	6.31	6.32	7.40	7.38	7.29	7.22	6.74	6.71	4.13	4.09
	6.52		7.78		7.38		6.33		7.37		7.15		6.68		4.04	
16-Nov-09	7.15	7.09	7.95	7.94	5.83	5.81	5.07	5.05	6.29	6.25	7.23	7.18	7.47	7.44	5.96	5.88
	7.03		7.94		5.79		5.02		6.21		7.12		7.41		5.80	

Projected DO Monitoring Data (Wet Season) adjusted with Mean Variation Percentage of EPD Marine Monitoring Data (2006 - 2008)

Mid-flood	RW21		C1		C2		C3		C4		C5		C6		C7	
Date	Value	Average	Value	Average	Value	Average	Value	Average	Value	Average	Value	Average	Value	Average	Value	Average
21-Oct-09	4.24	4.20	4.25	4.14	4.04	4.01	3.99	3.96	3.99	3.91	4.14	4.11	3.14	3.11	3.64	3.57
	4.17		4.04		3.99		3.93		3.84		4.08		3.08		3.50	
23-Oct-09	3.89	3.89	4.13	4.07	3.78	3.66	3.77	3.72	3.77	3.68	4.36	4.11	2.53	2.44	3.14	3.08
	3.89		4.01		3.54		3.66		3.59		3.86		2.35		3.02	
27-Oct-09	3.89	3.88	4.15	4.15	3.93	3.86	3.95	3.93	4.07	4.02	3.99	3.94	3.18	3.06	3.36	3.18
	3.86		4.15		3.80		3.90		3.98		3.90		2.94		3.00	
29-Oct-09	4.25	4.23	4.33	4.32	4.19	4.15	4.11	4.12	4.10	4.06	4.20	4.16	3.34	3.14	3.78	3.72
	4.21		4.31		4.11		4.12		4.03		4.11		2.94		3.66	
31-Oct-09	4.67	4.66	4.31	4.31	4.35	4.34	4.52	4.50	4.58	4.52	4.50	4.45	3.60	3.55	3.82	3.78
	4.65		4.30		4.32		4.49		4.46		4.40		3.51		3.75	
2-Nov-09	4.72	4.44	4.29	4.28	4.19	4.15	4.53	4.44	4.21	4.19	4.75	4.45	3.44	3.40	3.86	3.54
	4.17		4.27		4.10		4.34		4.17		4.16		3.36		3.22	
4-Nov-09	4.28	4.36	4.05	4.08	4.79	4.64	4.77	4.76	4.69	4.67	4.32	4.27	3.44	3.39	3.48	3.45
	4.44		4.11		4.48		4.75		4.65		4.23		3.34		3.42	
6-Nov-09	4.08	4.07	4.19	4.16	4.20	4.16	4.12	4.11	4.10	4.08	4.24	4.20	3.09	3.04	3.48	3.43
	4.07		4.12		4.11		4.10		4.06		4.17		2.99		3.38	
10-Nov-09	4.10	4.09	4.18	4.18	4.05	4.01	3.97	3.97	3.95	3.92	4.06	4.01	3.19	3.00	3.64	3.58
	4.07		4.17		3.97		3.98		3.89		3.97		2.80		3.51	
12-Nov-09	3.67	3.65	3.30	3.28	3.43	3.41	3.55	3.54	3.46	3.43	3.46	3.43	2.47	2.44	2.57	2.54
	3.62		3.25		3.38		3.53		3.41		3.41		2.41		2.52	
14-Nov-09	3.86	3.78	3.96	3.98	4.00	3.98	3.82	3.78	3.55	3.54	3.41	3.34	2.83	2.84	2.76	2.78
	3.69		4.00		3.97		3.74		3.53		3.28		2.85		2.79	
16-Nov-09	4.10	4.05	4.77	4.81	3.57	3.53	3.86	3.83	3.88	3.84	3.96	3.92	2.82	2.84	3.55	3.41
	4.00		4.86		3.50		3.80		3.81		3.87		2.86		3.26	

Mid-Ebb	RW21		C1		C2		C3		C4		C5		C6		C7	
Date	Value	Average	Value	Average	Value	Average	Value	Average	Value	Average	Value	Average	Value	Average	Value	Average
21-Oct-09	4.08	4.06	4.07	4.02	4.00	4.00	4.23	4.19	4.33	4.32	3.81	3.81	3.34	3.33	3.28	3.27
	4.04		3.97		4.00		4.15		4.32		3.81		3.32		3.26	
23-Oct-09	4.41	4.32	3.92	3.92	3.60	3.57	3.65	3.61	3.57	3.53	3.64	3.58	3.29	3.14	3.39	3.27
	4.24		3.92		3.53		3.58		3.50		3.52		3.00		3.15	
27-Oct-09	4.17	4.12	4.30	4.22	4.25	4.18	4.05	4.00	4.10	4.03	3.85	3.80	3.84	3.64	3.30	3.31
	4.08		4.15		4.10		3.95		3.97		3.74		3.44		3.32	
29-Oct-09	4.32	4.31	4.17	4.11	4.49	4.47	4.45	4.39	4.27	4.26	4.33	4.31	2.75	2.71	3.20	3.18
	4.30		4.06		4.44		4.33		4.26		4.28		2.66		3.16	
31-Oct-09	4.52	4.48	4.65	4.64	4.57	4.52	4.27	4.26	4.28	4.27	4.52	4.41	4.01	3.54	3.66	3.56
	4.44		4.62		4.48		4.25		4.25		4.30		3.07		3.47	
2-Nov-09	4.92	4.94	4.46	4.39	4.61	4.55	4.24	4.23	4.33	4.31	4.64	4.56	3.99	3.91	4.29	4.18
	4.97		4.31		4.48		4.23		4.29		4.49		3.83		4.08	
4-Nov-09	4.14	4.12	5.05	5.03	4.50	4.49	4.28	4.28	4.19	4.16	4.41	4.25	4.00	3.91	4.40	4.28
	4.10		5.01		4.48		4.28		4.12		4.10		3.83		4.16	
6-Nov-09	3.59	3.58	4.28	4.27	3.94	3.91	3.89	3.87	3.66	3.64	3.56	3.55	3.40	3.38	3.56	3.55
	3.58		4.25		3.87		3.84		3.62		3.54		3.36		3.54	
10-Nov-09	4.18	4.17	4.02	3.97	4.35	4.32	4.31	4.25	4.12	4.12	4.18	4.16	2.61	2.57	3.06	3.04
	4.16		3.92		4.30		4.18		4.11		4.14		2.52		3.01	
12-Nov-09	3.44	3.43	3.54	3.52	3.45	3.44	3.64	3.61	3.47	3.45	3.57	3.54	2.51	2.49	2.69	2.68
	3.42		3.50		3.42		3.58		3.42		3.51		2.48		2.66	
14-Nov-09	4.14	4.13	4.07	3.97	4.10	4.14	4.11	4.09	4.08	4.04	4.26	4.25	3.48	3.44	3.52	3.51
	4.11		3.86		4.18		4.07		4.01		4.25		3.40		3.51	
16-Nov-09	5.66	5.64	3.59	3.61	5.14	5.05	5.56	5.50	4.99	4.90	5.46	5.46	5.04	4.85	4.60	4.59
	5.62		3.62		4.95		5.45		4.80		5.46		4.66		4.58	

Projected DO Monitoring Data (Wet Season) adjusted with Mean Variation Percentage of EPD Marine Monitoring Data (2006 - 2008)

Mid-flood	C8		C9		RC1		RC5		RC7	
Date	Value	Average	Value	Average	Value	Average	Value	Average	Value	Average
21-Oct-09	4.50	4.50	4.47	4.40	3.71	3.71	4.06	4.06	3.16	3.16
	4.50		4.33		3.71		4.07		3.16	
23-Oct-09	3.80	3.74	3.47	3.46	3.74	3.74	3.52	3.51	3.19	3.01
	3.69		3.45		3.74		3.51		2.83	
27-Oct-09	3.53	3.41	3.83	3.48	3.95	3.90	4.04	4.02	4.52	3.90
	3.29		3.14		3.84		4.01		3.28	
29-Oct-09	3.77	3.72	3.22	3.17	4.16	4.14	4.24	4.23	3.72	3.66
	3.66		3.13		4.13		4.22		3.59	
31-Oct-09	4.20	4.15	3.67	3.64	4.47	4.44	4.72	4.74	3.82	3.76
	4.11		3.62		4.41		4.76		3.70	
2-Nov-09	3.65	3.59	4.44	4.24	4.05	4.03	3.95	3.92	3.61	3.47
	3.53		4.03		4.01		3.88		3.34	
4-Nov-09	3.95	3.93	4.15	4.10	5.19	5.17	4.29	4.27	3.47	3.37
	3.92		4.05		5.16		4.26		3.27	
6-Nov-09	4.02	4.01	4.22	4.19	4.04	4.01	4.26	4.21	3.22	3.18
	4.01		4.16		3.99		4.17		3.14	
10-Nov-09	3.63	3.57	3.07	3.03	4.01	4.00	4.10	4.09	3.58	3.51
	3.52		2.98		3.99		4.08		3.45	
12-Nov-09	3.61	3.59	3.62	3.58	3.49	3.45	3.48	3.46	1.53	1.51
	3.57		3.55		3.42		3.44		1.49	
14-Nov-09	4.21	4.18	4.09	4.07	4.27	4.26	3.54	3.52	1.93	1.91
	4.14		4.06		4.25		3.50		1.90	
16-Nov-09	5.77	5.76	5.74	5.65	3.24	3.26	3.86	3.88	3.86	3.86
	5.74		5.56		3.29		3.89		3.86	

Mid-Ebb	C8		C9		RC1		RC5		RC7	
Date	Value	Average	Value	Average	Value	Average	Value	Average	Value	Average
21-Oct-09	4.50	4.41	4.54	4.60	4.03	4.00	4.23	4.18	3.30	3.31
	4.33		4.65		3.96		4.12		3.32	
23-Oct-09	4.21	4.16	4.92	4.50	3.50	3.47	3.62	3.62	3.73	3.57
	4.12		4.08		3.45		3.62		3.41	
27-Oct-09	4.02	4.02	4.21	4.12	3.74	3.68	3.76	3.74	4.09	3.86
	4.02		4.03		3.63		3.72		3.64	
29-Oct-09	4.00	3.99	4.33	4.27	4.24	4.24	4.32	4.27	3.66	3.47
	3.99		4.21		4.24		4.23		3.28	
31-Oct-09	4.29	4.28	4.42	4.36	4.10	4.10	4.40	4.33	3.72	3.65
	4.27		4.31		4.11		4.26		3.58	
2-Nov-09	4.49	4.46	3.53	3.59	4.28	4.24	5.04	5.02	4.27	4.17
	4.44		3.65		4.20		4.99		4.06	
4-Nov-09	5.22	5.21	5.16	5.14	4.21	4.18	4.12	4.13	4.51	4.45
	5.20		5.12		4.14		4.13		4.39	
6-Nov-09	4.91	4.89	4.81	4.77	3.74	3.73	3.69	3.65	3.52	3.50
	4.86		4.72		3.72		3.61		3.47	
10-Nov-09	3.85	3.85	4.19	4.12	4.10	4.10	4.18	4.13	3.51	3.33
	3.84		4.06		4.10		4.09		3.14	
12-Nov-09	3.73	3.69	3.57	3.54	3.56	3.52	3.39	3.38	2.44	2.43
	3.65		3.51		3.49		3.37		2.41	
14-Nov-09	3.98	4.02	4.12	4.13	4.12	4.11	4.10	4.12	3.20	3.22
	4.05		4.15		4.10		4.14		3.24	
16-Nov-09	5.79	5.76	5.37	5.36	5.24	5.27	6.18	6.07	4.94	4.94
	5.74		5.34		5.30		5.96		4.94	

Baseline SS Monitoring Data (Oct - Nov 2009)

Mid-flood Date	WSD7		WSD9		WSD10		WSD15		WSD17		WSD19		WSD20		WSD21		RW1		
	Value	Average	Value	Average	Value	Average	Value	Average	Value	Average	Value	Average	Value	Average	Value	Average	Value	Average	
21-Oct-09	11.0	11.5	11.0	10.5	9.0	8.5	7.0	7.5	10.0	10.0	9.0	9.5	11.0	11.5	14.0	14.0	10.0	9.0	
	12.0		10.0		8.0		8.0		10.0		10.0		12.0		14.0		8.0		
23-Oct-09	10.0	11.5	6.0	6.0	8.0	7.0	11.0	10.5	9.0	9.5	11.0	11.0	13.0	13.0	14.0	13.0	14.0	14.0	13.5
	13.0		6.0		6.0		10.0		10.0		11.0		13.0		12.0		13.0		
27-Oct-09	12.0	12.5	10.0	10.5	9.0	8.5	10.0	10.0	11.0	10.5	12.0	11.0	8.0	8.0	10.0	10.0	10.0	10.0	11.0
	13.0		11.0		8.0		10.0		10.0		8.0		10.0		12.0				
29-Oct-09	14.0	14.0	8.0	8.5	8.0	7.5	9.0	9.0	7.0	7.0	7.0	7.5	7.0	6.5	13.0	12.0	12.0	12.0	12.0
	14.0		9.0		7.0		9.0		7.0		8.0		6.0		11.0		12.0		
31-Oct-09	13.0	12.0	8.0	7.0	7.0	7.5	8.0	8.0	12.0	11.0	11.0	12.0	8.0	8.0	11.0	10.0	9.0	9.0	9.0
	11.0		6.0		8.0		8.0		10.0		13.0		8.0		9.0		9.0		
2-Nov-09	13.0	12.5	10.0	9.5	11.0	10.0	9.0	8.5	8.0	8.5	11.0	10.0	9.0	10.0	8.0	7.5	9.0	9.0	9.0
	12.0		9.0		9.0		8.0		9.0		11.0		7.0		9.0		9.0		
4-Nov-09	12.0	13.0	9.0	8.5	8.0	9.0	10.0	11.0	9.0	8.5	8.0	8.5	10.0	11.5	13.0	12.5	9.0	9.0	10.0
	14.0		8.0		10.0		12.0		8.0		9.0		13.0		12.0		11.0		12.0
6-Nov-09	18.0	18.5	8.0	8.0	7.0	8.0	8.0	9.0	9.0	10.0	8.0	9.0	11.0	11.5	10.0	9.5	12.0	12.0	12.0
	19.0		8.0		9.0		10.0		10.0		12.0		9.0		12.0				
10-Nov-09	12.0	13.0	10.0	11.0	13.0	12.5	6.0	6.5	13.0	12.5	14.0	14.5	7.0	8.0	10.0	10.5	10.0	10.0	11.0
	14.0		12.0		7.0		12.0		15.0		9.0		11.0		12.0				
12-Nov-09	11.0	11.0	7.0	8.0	5.0	4.5	8.0	7.5	14.0	13.5	12.0	11.5	6.0	6.5	10.0	9.5	9.0	9.0	9.0
	11.0		9.0		4.0		7.0		13.0		11.0		7.0		9.0		9.0		
14-Nov-09	9.0	8.0	7.0	6.0	10.0	9.5	9.0	8.5	8.0	8.0	12.0	11.5	10.0	10.0	11.0	10.5	7.0	7.0	7.5
	7.0		5.0		9.0		8.0		11.0		10.0		10.0		8.0				
16-Nov-09	8.0	9.0	6.0	6.5	4.0	4.5	6.0	7.0	6.0	6.0	6.0	6.0	6.0	7.0	6.0	5.0	6.0	6.0	6.5
	10.0		7.0		5.0		8.0		6.0		6.0		8.0		7.0				

Mid-Ebb Date	WSD7		WSD9		WSD10		WSD15		WSD17		WSD19		WSD20		WSD21		RW1		
	Value	Average	Value	Average	Value	Average	Value	Average	Value	Average	Value	Average	Value	Average	Value	Average	Value	Average	
21-Oct-09	9.0	8.5	7.0	7.0	8.0	7.5	6.0	6.5	16.0	15.5	14.0	13.0	9.0	10.0	9.0	9.5	9.0	9.0	9.5
	8.0		7.0		7.0		7.0		15.0		12.0		11.0		10.0		10.0		
23-Oct-09	8.0	8.0	8.0	8.0	8.0	7.0	6.0	5.5	9.0	8.5	10.0	9.5	5.0	6.0	11.0	10.5	10.0	10.0	11.0
	8.0		6.0		5.0		8.0		9.0		7.0		10.0		12.0				
27-Oct-09	10.0	9.5	6.0	5.0	9.0	8.0	7.0	7.5	8.0	7.5	7.0	6.5	7.0	7.5	7.0	8.0	9.0	9.0	8.5
	9.0		4.0		7.0		8.0		7.0		6.0		8.0		9.0		8.0		
29-Oct-09	12.0	11.5	8.0	8.0	8.0	8.0	8.0	8.5	8.0	8.5	8.0	9.0	9.0	8.5	8.0	9.0	9.0	9.0	9.0
	11.0		8.0		8.0		9.0		10.0		8.0		10.0		9.0		9.0		
31-Oct-09	10.0	9.0	8.0	7.0	9.0	10.0	7.0	6.0	9.0	9.5	9.0	9.0	11.0	11.0	11.0	10.5	10.0	10.0	10.0
	8.0		6.0		11.0		5.0		10.0		9.0		11.0		10.0		10.0		
2-Nov-09	12.0	11.5	7.0	8.0	6.0	6.5	12.0	11.0	12.0	12.0	9.0	8.5	8.0	7.5	10.0	10.5	8.0	9.0	8.5
	11.0		9.0		7.0		10.0		12.0		8.0		7.0		11.0		9.0		
4-Nov-09	7.0	8.0	7.0	6.5	6.0	7.0	11.0	12.5	5.0	6.0	9.0	8.5	7.0	8.0	10.0	10.5	10.0	10.0	9.5
	9.0		6.0		8.0		14.0		7.0		8.0		9.0		11.0		9.0		
6-Nov-09	11.0	10.0	6.0	6.5	7.0	6.5	11.0	10.0	10.0	9.0	10.0	9.0	8.0	9.0	9.0	8.5	11.0	11.0	10.0
	9.0		7.0		6.0		9.0		8.0		10.0		8.0		9.0				
10-Nov-09	8.0	9.0	9.0	9.0	8.0	7.0	6.0	7.0	9.0	8.5	5.0	5.5	7.0	7.0	8.0	8.0	9.0	9.0	8.0
	10.0		9.0		6.0		8.0		8.0		6.0		7.0		8.0		7.0		
12-Nov-09	8.0	7.5	6.0	5.5	5.0	5.5	10.0	9.0	9.0	9.0	9.0	9.5	5.0	5.5	11.0	10.5	10.0	10.0	10.5
	7.0		5.0		6.0		8.0		10.0		6.0		10.0		10.0		11.0		
14-Nov-09	6.0	6.0	7.0	6.5	8.0	7.5	8.0	8.0	8.0	8.5	9.0	8.0	7.0	7.0	10.0	11.0	11.0	11.0	10.5
	6.0		6.0		7.0		8.0		9.0		7.0		12.0		10.0				
16-Nov-09	7.0	6.5	8.0	8.0	4.0	5.0	6.0	7.0	11.0	9.5	4.0	4.0	8.0	8.5	8.0	8.0	10.0	10.0	9.0
	6.0		8.0		6.0		8.0		11.0		4.0		9.0		8.0				

Baseline SS Monitoring Data (Oct - Nov 2009)

Mid-flood Date	C1		C2		C3		C4		C5		C6		C7		C8		C9	
	Value	Average	Value	Average	Value	Average	Value	Average	Value	Average	Value	Average	Value	Average	Value	Average	Value	Average
21-Oct-09	8.0	8.0	9.0	8.5	9.0	9.5	11.0	11.5	14.0	14.5	6.0	6.5	6.0	6.5	12.0	11.0	11.0	11.0
	8.0		8.0		10.0		12.0		15.0		7.0		7.0		10.0		11.0	
23-Oct-09	12.0	11.5	12.0	12.5	14.0	12.5	14.0	14.0	15.0	14.0	10.0	9.0	11.0	12.0	21.0	19.5	23.0	21.5
	11.0		13.0		11.0		14.0		13.0		8.0		13.0		18.0		20.0	
27-Oct-09	13.0	12.5	8.0	9.0	9.0	8.0	11.0	10.0	11.0	11.5	10.0	10.5	10.0	9.0	15.0	14.0	23.0	23.0
	12.0		10.0		7.0		9.0		12.0		11.0		8.0		13.0		23.0	
29-Oct-09	18.0	18.5	10.0	11.0	11.0	11.0	15.0	14.5	11.0	11.5	10.0	9.5	12.0	11.5	16.0	16.0	23.0	23.5
	19.0		12.0		11.0		14.0		12.0		9.0		11.0		16.0		24.0	
31-Oct-09	11.0	10.5	10.0	10.0	15.0	15.0	10.0	9.5	9.0	9.5	8.0	7.0	6.0	7.0	14.0	13.5	19.0	18.5
	10.0		10.0		15.0		9.0		10.0		6.0		8.0		13.0		18.0	
2-Nov-09	9.0	9.0	8.0	8.0	8.0	8.5	7.0	7.0	5.0	5.5	8.0	9.0	9.0	9.0	10.0	10.0	10.0	10.5
	9.0		8.0		9.0		7.0		6.0		10.0		9.0		10.0		11.0	
4-Nov-09	10.0	11.5	9.0	9.5	10.0	10.0	9.0	9.5	10.0	10.5	4.0	5.0	8.0	8.0	13.0	12.5	14.0	14.0
	13.0		10.0		10.0		10.0		11.0		6.0		8.0		12.0		14.0	
6-Nov-09	13.0	12.0	9.0	8.5	14.0	13.0	14.0	13.5	16.0	15.0	10.0	9.5	9.0	9.0	19.0	17.5	12.0	12.0
	11.0		8.0		12.0		13.0		14.0		9.0		9.0		16.0		12.0	
10-Nov-09	9.0	8.5	11.0	10.5	12.0	11.5	10.0	10.5	10.0	10.0	7.0	7.0	8.0	7.0	14.0	12.5	13.0	13.0
	8.0		10.0		11.0		11.0		10.0		7.0		6.0		11.0		13.0	
12-Nov-09	10.0	10.0	10.0	10.0	10.0	10.0	11.0	11.0	10.0	9.5	10.0	11.0	8.0	9.0	24.0	22.0	18.0	18.5
	10.0		10.0		10.0		11.0		9.0		12.0		10.0		20.0		19.0	
14-Nov-09	6.0	7.0	9.0	10.0	12.0	11.0	12.0	13.0	16.0	14.5	8.0	7.5	7.0	7.0	14.0	14.5	16.0	15.0
	8.0		11.0		10.0		14.0		13.0		7.0		7.0		15.0		14.0	
16-Nov-09	5.0	5.5	8.0	7.0	6.0	6.5	12.0	11.0	6.0	6.0	6.0	7.0	9.0	9.0	7.0	6.0	6.0	6.0
	6.0		6.0		7.0		10.0		6.0		8.0		9.0		5.0		6.0	

Mid-Ebb Date	C1		C2		C3		C4		C5		C6		C7		C8		C9	
	Value	Average	Value	Average	Value	Average	Value	Average	Value	Average	Value	Average	Value	Average	Value	Average	Value	Average
21-Oct-09	10.0	10.5	8.0	7.0	8.0	7.0	11.0	11.5	10.0	10.5	7.0	7.5	5.0	5.5	10.0	11.0	20.0	18.5
	11.0		6.0		6.0		12.0		11.0		8.0		6.0		12.0		17.0	
23-Oct-09	6.0	5.5	14.0	14.5	10.0	10.0	9.0	9.5	11.0	12.0	10.0	9.0	8.0	7.0	13.0	12.5	10.0	11.5
	5.0		15.0		10.0		10.0		13.0		8.0		6.0		12.0		13.0	
27-Oct-09	4.0	4.5	7.0	6.0	6.0	5.0	8.0	8.0	8.0	8.0	7.0	7.0	5.0	5.0	9.0	9.0	10.0	10.0
	5.0		5.0		4.0		8.0		8.0		7.0		5.0		9.0		10.0	
29-Oct-09	9.0	9.5	10.0	9.0	11.0	10.5	7.0	6.5	9.0	10.0	9.0	8.5	8.0	7.5	12.0	12.0	13.0	13.0
	10.0		8.0		10.0		6.0		11.0		8.0		7.0		12.0		13.0	
31-Oct-09	10.0	9.5	9.0	8.5	11.0	10.0	10.0	10.0	12.0	11.0	12.0	11.0	6.0	5.5	12.0	11.0	13.0	13.5
	9.0		8.0		9.0		10.0		10.0		5.0		10.0		14.0			
2-Nov-09	11.0	10.0	10.0	10.0	12.0	13.0	13.0	12.5	12.0	12.5	10.0	9.0	9.0	8.5	12.0	13.0	13.0	12.0
	9.0		10.0		14.0		12.0		13.0		8.0		8.0		14.0		11.0	
4-Nov-09	6.0	7.0	8.0	8.5	8.0	8.5	13.0	13.5	11.0	12.5	6.0	6.0	10.0	9.0	12.0	12.5	14.0	13.5
	8.0		9.0		9.0		14.0		14.0		8.0		8.0		13.0		13.0	
6-Nov-09	6.0	6.0	7.0	8.0	7.0	6.5	9.0	9.5	11.0	11.5	8.0	8.0	9.0	8.0	9.0	10.0	12.0	13.0
	6.0		9.0		6.0		10.0		12.0		8.0		7.0		11.0		14.0	
10-Nov-09	8.0	8.0	5.0	5.0	6.0	6.0	6.0	6.5	8.0	8.0	9.0	8.0	7.0	7.0	10.0	9.5	8.0	8.0
	8.0		5.0		6.0		7.0		8.0		7.0		7.0		9.0		8.0	
12-Nov-09	6.0	7.0	7.0	7.0	7.0	7.5	8.0	9.0	16.0	15.0	7.0	6.5	7.0	5.5	8.0	8.5	12.0	12.5
	8.0		7.0		8.0		10.0		14.0		6.0		4.0		9.0		13.0	
14-Nov-09	9.0	10.0	10.0	9.5	9.0	9.5	11.0	12.0	11.0	10.5	10.0	9.0	5.0	5.5	10.0	10.0	14.0	13.0
	11.0		9.0		10.0		13.0		10.0		8.0		6.0		10.0		12.0	
16-Nov-09	6.0	6.5	8.0	7.5	7.0	6.5	8.0	8.5	7.0	7.5	10.0	9.0	8.0	7.0	8.0	8.5	7.0	7.0
	7.0		7.0		6.0		9.0		8.0		6.0		9.0		9.0		7.0	

Baseline SS Monitoring Data (Oct - Nov 2009)

Mid-flood Date	RC1		RC5		RC7	
	Value	Average	Value	Average	Value	Average
21-Oct-09	7.0	7.0	15.0	14.0	8.0	8.0
	7.0		13.0		8.0	
23-Oct-09	10.0	10.0	12.0	11.0	11.0	12.0
	10.0		10.0		13.0	
27-Oct-09	8.0	7.5	11.0	11.5	25.0	23.5
	7.0		12.0		22.0	
29-Oct-09	14.0	13.0	12.0	11.5	9.0	9.0
	12.0		11.0		9.0	
31-Oct-09	9.0	9.5	8.0	7.5	7.0	7.0
	10.0		7.0		7.0	
2-Nov-09	8.0	7.5	9.0	8.0	7.0	6.5
	7.0		7.0		6.0	
4-Nov-09	8.0	8.0	10.0	10.0	8.0	7.5
	8.0		10.0		7.0	
6-Nov-09	16.0	15.5	12.0	11.5	9.0	9.0
	15.0		11.0		9.0	
10-Nov-09	9.0	9.5	8.0	8.0	6.0	6.5
	10.0		8.0		7.0	
12-Nov-09	6.0	7.0	10.0	9.5	6.0	6.5
	8.0		9.0		7.0	
14-Nov-09	11.0	12.5	8.0	9.0	10.0	10.0
	14.0		10.0		10.0	
16-Nov-09	5.0	6.0	6.0	6.5	7.0	6.5
	7.0		7.0		6.0	

Mid-Ebb Date	RC1		RC5		RC7	
	Value	Average	Value	Average	Value	Average
21-Oct-09	7.0	7.5	8.0	8.5	6.0	5.5
	8.0		9.0		5.0	
23-Oct-09	7.0	6.5	7.0	7.0	13.0	12.5
	6.0		7.0		12.0	
27-Oct-09	6.0	5.0	5.0	5.5	10.0	10.0
	4.0		6.0		10.0	
29-Oct-09	9.0	9.5	10.0	9.5	10.0	9.0
	10.0		9.0		8.0	
31-Oct-09	10.0	9.5	8.0	8.5	10.0	10.0
	9.0		9.0		10.0	
2-Nov-09	10.0	11.0	9.0	9.0	8.0	7.5
	12.0		9.0		7.0	
4-Nov-09	6.0	6.5	10.0	10.0	9.0	9.5
	7.0		10.0		10.0	
6-Nov-09	8.0	8.5	8.0	8.5	9.0	9.0
	9.0		9.0		9.0	
10-Nov-09	7.0	7.0	8.0	7.5	8.0	8.0
	7.0		7.0		8.0	
12-Nov-09	9.0	8.5	11.0	10.5	9.0	8.0
	8.0		10.0		7.0	
14-Nov-09	8.0	7.0	10.0	9.5	10.0	9.0
	6.0		9.0		8.0	
16-Nov-09	6.0	6.5	9.0	9.0	7.0	7.0
	7.0		9.0		7.0	

Projected SS Monitoring Data (Wet Season) adjusted with Mean Variation Percentage of EPD Marine Monitoring Data (2006 - 2008)

Mid-flood	WSD7		WSD9		WSD10		WSD15		WSD17		WSD19		WSD20		WSD21	
Date	Value	Average	Value	Average	Value	Average	Value	Average	Value	Average	Value	Average	Value	Average	Value	Average
21-Oct-09	10.8	11.3	13.7	13.1	10.6	10.0	12.6	13.6	11.8	11.8	8.4	8.8	7.9	8.3	17.2	17.2
	11.8		12.4		9.4		14.5		11.8		9.3		8.7			
23-Oct-09	9.9	11.3	7.5	7.5	9.4	8.2	19.9	19.0	10.6	11.2	10.2	10.2	9.4	9.4	17.2	16.0
	12.8		7.5		7.1		18.1		11.8		10.2		9.4			
27-Oct-09	11.8	12.3	12.4	13.1	10.6	10.0	18.1	18.1	13.0	12.4	11.1	10.2	5.8	5.8	12.3	12.3
	12.8		13.7		9.4		18.1		11.8		9.3		5.8			
29-Oct-09	13.8	13.8	10.0	10.6	9.4	8.8	16.3	16.3	8.2	8.2	6.5	7.0	5.1	4.7	16.0	14.7
	13.8		11.2		8.2		16.3		8.2		7.4		4.3			
31-Oct-09	12.8	11.8	10.0	8.7	8.2	8.8	14.5	14.5	14.1	13.0	10.2	11.1	5.8	5.8	13.5	12.3
	10.8		7.5		9.4		14.5		11.8		12.1		5.8			
2-Nov-09	12.8	12.3	12.4	11.8	13.0	11.8	16.3	15.4	9.4	10.0	10.2	9.3	6.5	7.2	9.8	9.2
	11.8		11.2		10.6		14.5		10.6		8.4		7.9			
4-Nov-09	11.8	12.8	11.2	10.6	9.4	10.6	18.1	19.9	10.6	10.0	7.4	7.9	7.2	8.3	16.0	15.3
	13.8		10.0		11.8		21.7		9.4		8.4		9.4			
6-Nov-09	17.7	18.2	10.0	10.0	8.2	9.4	14.5	16.3	10.6	11.8	7.4	8.4	7.9	8.3	12.3	11.7
	18.7		10.0		10.6		18.1		13.0		9.3		8.7			
10-Nov-09	11.8	12.8	12.4	13.7	15.3	14.7	10.8	11.7	15.3	14.7	13.0	13.5	5.1	5.8	12.3	12.9
	13.8		14.9		14.1		12.6		14.1		13.9		6.5			
12-Nov-09	10.8	10.8	8.7	10.0	5.9	5.3	14.5	13.6	16.5	15.9	11.1	10.7	4.3	4.7	12.3	11.7
	10.8		11.2		4.7		12.6		15.3		10.2		5.1			
14-Nov-09	8.9	7.9	8.7	7.5	11.8	11.2	16.3	15.4	9.4	9.4	11.1	10.7	7.2	7.2	13.5	12.9
	6.9		6.2		10.6		14.5		9.4		10.2		7.2			
16-Nov-09	7.9	8.9	7.5	8.1	4.7	5.3	10.8	12.6	7.1	7.1	5.6	5.6	4.3	5.1	7.4	6.1
	9.9		8.7		5.9		14.5		7.1		5.6		5.8			

Mid-Ebb	WSD7		WSD9		WSD10		WSD15		WSD17		WSD19		WSD20		WSD21	
Date	Value	Average	Value	Average	Value	Average	Value	Average	Value	Average	Value	Average	Value	Average	Value	Average
21-Oct-09	8.9	8.4	8.7	8.7	9.4	8.8	10.8	11.7	18.9	18.3	13.0	12.1	6.5	7.2	11.0	11.7
	7.9		8.7		8.2		12.6		17.7		11.1		7.9			
23-Oct-09	7.9	7.9	10.0	10.0	9.4	8.2	10.8	9.9	10.6	10.0	9.3	8.8	3.6	4.3	13.5	12.9
	7.9		10.0		7.1		9.0		9.4		8.4		5.1			
27-Oct-09	9.9	9.4	7.5	6.2	10.6	9.4	12.6	13.6	9.4	8.8	6.5	6.0	5.1	5.4	8.6	9.8
	8.9		5.0		8.2		14.5		8.2		5.6		5.8			
29-Oct-09	11.8	11.3	10.0	10.0	9.4	9.4	14.5	15.4	9.4	10.0	7.4	8.4	6.5	6.1	9.8	11.0
	10.8		10.0		9.4		16.3		10.6		9.3		5.8			
31-Oct-09	9.9	8.9	10.0	8.7	10.6	11.8	12.6	10.8	10.6	11.2	8.4	8.4	7.9	7.9	13.5	12.9
	7.9		7.5		13.0		9.0		11.8		8.4		7.9			
2-Nov-09	11.8	11.3	8.7	10.0	7.1	7.7	21.7	19.9	14.1	14.1	8.4	7.9	5.8	5.4	12.3	12.9
	10.8		11.2		8.2		18.1		14.1		7.4		5.1			
4-Nov-09	6.9	7.9	8.7	8.1	7.1	8.2	19.9	22.6	5.9	7.1	8.4	7.9	5.1	5.8	12.3	12.9
	8.9		7.5		9.4		25.3		8.2		7.4		6.5			
6-Nov-09	10.8	9.9	7.5	8.1	8.2	7.7	19.9	18.1	11.8	10.6	9.3	8.4	5.8	6.5	11.0	10.4
	8.9		8.7		7.1		16.3		9.4		7.4		7.2			
10-Nov-09	7.9	8.9	11.2	11.2	9.4	8.2	10.8	12.6	10.6	10.0	4.6	5.1	5.1	5.1	9.8	9.8
	9.9		11.2		7.1		14.5		9.4		5.6		5.1			
12-Nov-09	7.9	7.4	7.5	6.8	5.9	6.5	18.1	16.3	10.6	10.6	8.4	8.8	3.6	4.0	13.5	12.9
	6.9		6.2		7.1		14.5		10.6		9.3		4.3			
14-Nov-09	5.9	5.9	8.7	8.1	9.4	8.8	14.5	14.5	9.4	10.0	8.4	7.4	5.1	5.1	12.3	13.5
	5.9		7.5		8.2		14.5		10.6		6.5		5.1			
16-Nov-09	6.9	6.4	10.0	10.0	4.7	5.9	10.8	12.6	13.0	11.2	3.7	3.7	5.8	6.1	9.8	9.8
	5.9		10.0		7.1		14.5		9.4		3.7		6.5			

Projected SS Monitoring Data (Wet Season) adjusted with Mean Variation Percentage of EPD Marine Monitoring Data (2006 - 2008)

Mid-flood	RW21		C1		C2		C3		C4		C5		C6		C7	
Date	Value	Average	Value	Average	Value	Average	Value	Average	Value	Average	Value	Average	Value	Average	Value	Average
21-Oct-09	12.3	11.0	9.8	9.8	11.0	10.4	11.0	11.7	13.5	14.1	17.2	17.8	7.4	8.0	7.4	8.0
	9.8		9.8		9.8		12.3		14.7		18.4		8.6		8.6	
23-Oct-09	17.2	16.6	14.7	14.1	14.7	15.3	17.2	15.3	17.2	17.2	18.4	17.2	12.3	11.0	13.5	14.7
	16.0		13.5		16.0		13.5		17.2		16.0		9.8		16.0	
27-Oct-09	12.3	13.5	16.0	15.3	9.8	11.0	11.0	9.8	13.5	12.3	13.5	14.1	12.3	12.9	12.3	11.0
	14.7		14.7		12.3		8.6		11.0		14.7		13.5		9.8	
29-Oct-09	14.7	14.7	22.1	22.7	12.3	13.5	13.5	13.5	18.4	17.8	13.5	14.1	12.3	11.7	14.7	14.1
	14.7		23.3		14.7		13.5		17.2		14.7		11.0		13.5	
31-Oct-09	11.0	11.0	13.5	12.9	12.3	12.3	18.4	18.4	12.3	11.7	11.0	11.7	9.8	8.6	7.4	8.6
	11.0		12.3		12.3		18.4		11.0		12.3		7.4		9.8	
2-Nov-09	11.0	11.0	11.0	11.0	9.8	9.8	9.8	10.4	8.6	8.6	6.1	6.8	9.8	11.0	11.0	11.0
	11.0		11.0		9.8		11.0		8.6		7.4		12.3		11.0	
4-Nov-09	11.0	12.3	12.3	14.1	11.0	11.7	12.3	12.3	11.0	11.7	12.3	12.9	4.9	6.1	9.8	9.8
	13.5		16.0		12.3		12.3		12.3		13.5		7.4		9.8	
6-Nov-09	14.7	14.7	16.0	14.7	11.0	10.4	17.2	16.0	17.2	16.6	19.6	18.4	12.3	11.7	11.0	11.0
	14.7		13.5		9.8		14.7		16.0		17.2		11.0		11.0	
10-Nov-09	12.3	13.5	11.0	10.4	13.5	12.9	14.7	14.1	12.3	12.9	12.3	12.3	8.6	8.6	9.8	8.6
	14.7		9.8		12.3		13.5		13.5		12.3		8.6		7.4	
12-Nov-09	11.0	11.0	12.3	12.3	12.3	12.3	12.3	12.3	13.5	13.5	12.3	11.7	12.3	13.5	9.8	11.0
	11.0		12.3		12.3		13.5		11.0		14.7		12.3			
14-Nov-09	8.6	9.2	7.4	8.6	11.0	12.3	14.7	13.5	14.7	16.0	19.6	17.8	9.8	9.2	8.6	8.6
	9.8		9.8		13.5		12.3		17.2		16.0		8.6		8.6	
16-Nov-09	7.4	8.0	6.1	6.8	9.8	8.6	7.4	8.0	14.7	13.5	7.4	7.4	7.4	8.6	11.0	11.0
	8.6		7.4		7.4		8.6		12.3		7.4		9.8		11.0	

Mid-Ebb	RW21		C1		C2		C3		C4		C5		C6		C7	
Date	Value	Average	Value	Average	Value	Average	Value	Average	Value	Average	Value	Average	Value	Average	Value	Average
21-Oct-09	11.0	11.7	12.3	12.9	9.8	8.6	9.8	8.6	13.5	14.1	12.3	12.9	8.6	9.2	6.1	6.8
	12.3		13.5		7.4		7.4		14.7		13.5		9.8		7.4	
23-Oct-09	12.3	13.5	7.4	6.8	17.2	17.8	12.3	12.3	11.0	11.7	13.5	14.7	12.3	11.0	9.8	8.6
	14.7		6.1		18.4		12.3		12.3		16.0		9.8		7.4	
27-Oct-09	11.0	10.4	4.9	5.5	8.6	7.4	7.4	6.1	9.8	9.8	9.8	9.8	8.6	8.6	6.1	6.1
	9.8		6.1		6.1		4.9		9.8		9.8		8.6		6.1	
29-Oct-09	11.0	11.0	11.0	11.7	12.3	11.0	13.5	12.9	8.6	8.0	11.0	12.3	11.0	10.4	9.8	9.2
	11.0		12.3		9.8		12.3		7.4		13.5		9.8		8.6	
31-Oct-09	12.3	12.3	12.3	11.7	11.0	10.4	13.5	12.3	12.3	12.3	14.7	13.5	14.7	13.5	7.4	6.8
	12.3		11.0		9.8		11.0		12.3		12.3		12.3		6.1	
2-Nov-09	9.8	10.4	13.5	12.3	12.3	12.3	14.7	16.0	16.0	15.3	14.7	15.3	12.3	11.0	11.0	10.4
	11.0		11.0		12.3		17.2		14.7		16.0		9.8		9.8	
4-Nov-09	12.3	11.7	7.4	8.6	9.8	10.4	9.8	10.4	16.0	16.6	13.5	15.3	7.4	7.4	12.3	11.0
	11.0		9.8		11.0		17.2		17.2		7.4		9.8			
6-Nov-09	13.5	12.3	7.4	7.4	8.6	9.8	8.6	8.0	11.0	11.7	13.5	14.1	9.8	9.8	11.0	9.8
	11.0		7.4		11.0		7.4		12.3		14.7		9.8		8.6	
10-Nov-09	11.0	9.8	9.8	9.8	6.1	6.1	7.4	7.4	7.4	8.0	9.8	9.8	11.0	9.8	8.6	8.6
	8.6		9.8		6.1		7.4		8.6		9.8		8.6		8.6	
12-Nov-09	12.3	12.9	7.4	8.6	8.6	8.6	8.6	9.2	9.8	11.0	19.6	18.4	8.6	8.0	8.6	6.8
	13.5		9.8		8.6		9.8		12.3		17.2		7.4		4.9	
14-Nov-09	13.5	12.9	11.0	12.3	12.3	11.7	11.0	11.7	13.5	14.7	13.5	12.9	12.3	11.0	6.1	6.8
	12.3		13.5		11.0		12.3		16.0		12.3		9.8		7.4	
16-Nov-09	12.3	11.0	7.4	8.0	9.8	9.2	8.6	8.0	9.8	10.4	8.6	9.2	12.3	11.0	9.8	8.6
	9.8		8.6		8.6		7.4		11.0		9.8		9.8		7.4	

Projected SS Monitoring Data (Wet Season) adjusted with Mean Variation Percentage of EPD Marine Monitoring Data (2006 - 2008)

Mid-flood	C8		C9		RC1		RC5		RC7	
Date	Value	Average	Value	Average	Value	Average	Value	Average	Value	Average
21-Oct-09	14.9	13.7	13.7	13.7	8.6	8.6	18.4	17.2	9.8	9.8
	12.4		13.7		8.6		16.0		9.8	
23-Oct-09	26.1	24.3	28.6	26.8	12.3	12.3	14.7	13.5	13.5	14.7
	22.4		24.9		12.3		12.3		16.0	
27-Oct-09	18.7	17.4	28.6	28.6	9.8	9.2	13.5	14.1	30.7	28.9
	16.2		28.6		8.6		14.7		27.0	
29-Oct-09	19.9	19.9	28.6	29.2	17.2	16.0	14.7	14.1	11.0	11.0
	19.9		29.9		14.7		13.5		11.0	
31-Oct-09	17.4	16.8	23.6	23.0	11.0	11.7	9.8	9.2	8.6	8.6
	16.2		22.4		12.3		8.6		8.6	
2-Nov-09	12.4	12.4	12.4	13.1	9.8	9.2	11.0	9.8	8.6	8.0
	12.4		13.7		8.6		8.6		7.4	
4-Nov-09	16.2	15.6	17.4	17.4	9.8	9.8	12.3	12.3	9.8	9.2
	14.9		17.4		9.8		12.3		8.6	
6-Nov-09	23.6	21.8	14.9	14.9	19.6	19.0	14.7	14.1	11.0	11.0
	19.9		14.9		18.4		13.5		11.0	
10-Nov-09	17.4	15.6	16.2	16.2	11.0	11.7	9.8	9.8	7.4	8.0
	13.7		16.2		12.3		9.8		8.6	
12-Nov-09	29.9	27.4	22.4	23.0	7.4	8.6	12.3	11.7	7.4	8.0
	24.9		23.6		9.8		11.0		8.6	
14-Nov-09	17.4	18.0	19.9	18.7	13.5	15.3	9.8	11.0	12.3	12.3
	18.7		17.4		17.2		12.3		12.3	
16-Nov-09	8.7	7.5	7.5	7.5	6.1	7.4	7.4	8.0	8.6	8.0
	6.2		7.5		8.6		8.6		7.4	

Mid-Ebb	C8		C9		RC1		RC5		RC7	
Date	Value	Average	Value	Average	Value	Average	Value	Average	Value	Average
21-Oct-09	12.4	13.7	24.9	23.0	8.6	9.2	9.8	10.4	7.4	6.8
	14.9		21.2		9.8		11.0		6.1	
23-Oct-09	16.2	15.6	12.4	14.3	8.6	8.0	8.6	8.6	16.0	15.3
	14.9		16.2		7.4		8.6		14.7	
27-Oct-09	11.2	11.2	12.4	12.4	7.4	6.1	6.1	6.8	12.3	12.3
	11.2		12.4		4.9		7.4		12.3	
29-Oct-09	14.9	14.9	16.2	16.2	11.0	11.7	12.3	11.7	12.3	11.0
	14.9		16.2		12.3		11.0		9.8	
31-Oct-09	14.9	13.7	16.2	16.8	12.3	11.7	9.8	10.4	12.3	12.3
	12.4		17.4		11.0		11.0		12.3	
2-Nov-09	14.9	16.2	16.2	14.9	12.3	13.5	11.0	11.0	9.8	9.2
	17.4		13.7		14.7		11.0		8.6	
4-Nov-09	14.9	15.6	17.4	16.8	7.4	8.0	12.3	12.3	11.0	11.7
	16.2		16.2		8.6		12.3		12.3	
6-Nov-09	11.2	12.4	14.9	16.2	9.8	10.4	9.8	10.4	11.0	11.0
	13.7		17.4		11.0		11.0		11.0	
10-Nov-09	12.4	11.8	10.0	10.0	8.6	8.6	9.8	9.2	9.8	9.8
	11.2		10.0		8.6		8.6		9.8	
12-Nov-09	10.0	10.6	14.9	15.6	11.0	10.4	13.5	12.9	11.0	9.8
	11.2		16.2		9.8		12.3		8.6	
14-Nov-09	12.4	12.4	17.4	16.2	9.8	8.6	12.3	11.7	12.3	11.0
	12.4		14.9		7.4		11.0		9.8	
16-Nov-09	10.0	10.6	8.7	8.7	7.4	8.0	11.0	11.0	8.6	8.6
	11.2		8.7		8.6		11.0		8.6	

Contract no. HK/2009/05
 WanChai Development Phase II and Central-Wanchai Bypass
 Sampling, Field Measurement, Testing Works (Stage 1)

Existing Action and Limit Levels for Water Quality proposed as Dry Season AL & LL

Parameters	Action	Limit
WSD Salt Water Intakes		
SS in mg/L	13.00	14.43
Turbidity in NTU	8.04	9.49
DO in mg/L	3.66	3.28
Cooling Water Intakes		
SS in mg/L	15.00	22.13
Turbidity in NTU	9.10	10.25
DO in mg/L	3.36	2.73

Proposed Action and Limit Levels for Water Quality in Wet Season (with projection using EPD data)

Parameters	Action	Limit
WSD Salt Water Intakes		
SS in mg/L	16.26	19.74
Turbidity in NTU	10.01	11.54
DO in mg/L	3.17	2.63
Cooling Water Intakes		
SS in mg/L	18.42	27.54
Turbidity in NTU	11.35	12.71
DO in mg/L	3.02	2.44

Appendix K
Terms of Reference and Details for the
ENPC and CLG

(version 1.5)

Environmental Project Committee (ENPC) set up under Environmental Permits No. EP-356/2009, No. EP-364/2009 and EP-376/2009

1. Aim of ENPC
 - 1.1 The Condition 2.3 of the Environmental Permit No. EP-356/2009 stipulates that to oversee and facilitate effective control of the cumulative environmental impacts arising from potential multiple contracts for the construction of the entire Wan Chai Development Phase II (WDII) and Central-Wanchai Bypass (CWB) (hereafter referred to as the whole Project), the Permit Holder shall set up an Environmental Project Committee (ENPC) before the commencement of construction of the earliest components of the whole Project.
 - 1.2 The Condition 2.3 of the Environmental Permit No. EP-364/2009 also stipulates that to oversee and facilitate effective control of the cumulative environmental impacts arising from potential multiple contracts for the construction of the entire Wan Chai Development Phase II (WDII) and Central-Wanchai Bypass (CWB) (hereafter referred to as the whole Project), the Permit Holder shall liaise with the permit holder of environmental permit No. EP-356/2009 to jointly set up an Environmental Project Committee (ENPC). The ENPC shall be set up before the commencement of construction of the earliest components of the whole Project.
 - 1.3 The Condition 2.3 of the Environmental Permit No. EP-376/2009 also stipulates that to oversee and facilitate effective control of the cumulative environmental impacts arising from potential multiple contracts for the construction of the entire Wan Chai Development Phase II (WDII) and Central-Wan Chai Bypass (CWB) (hereafter referred to as the whole Project), the Permit Holder shall liaise with the permit holder of environmental permit No. EP-356/2009 and the permit holder of environmental permit No. EP-364/2009 to jointly set up an Environmental Project Committee (ENPC). The ENPC shall be set up before the commencement of construction of the earliest components of the whole Project.
 - 1.4 Hence the ENPC is set up to specifically meet the requirements in the Condition 2.3 of the Environmental Permits No. EP-356/2009, No. EP-364/2009 and No. EP-376/2009 (the EPs).
2. Terms of Reference
 - 2.1 The ENPC is set up to oversee and facilitate effective control of the cumulative environmental impacts arising from potential multiple contracts for the construction of the entire Wan Chai Development Phase II (WDII) and Central-Wan Chai Bypass (CWB) (hereafter referred to as the whole Project).
 - 2.2 Specifically the ENPC will :
 - (a) review regularly the cumulative environmental impacts arising from the works contracts for the construction of the whole Project;
 - (b) review the environmental performance of individual works contracts under the whole Project;

(version 1.5)

- (c) coordinate the actions of the parties concerned for improving the environmental performance of the works contracts under the whole Project in order to ensure compliance of the environmental permits conditions and the relevant legislations;
- (d) discuss any necessary liaison works to be conducted by the Community Liaison Groups (CLGs) set up under the EPs to address potential cumulative environmental impact issues arising from the whole Project;
- (e) coordinate the actions in respect of handling and resolving environmental complaints and issues raised in the CLGs;
- (f) communicate with Environmental Protection Department in respect of the ENPC; and
- (g) make recommendations and update under the relevant condition of the Permits on how to enhance the monitoring and audit of the environmental performance of the whole Project on top of requirements as set out in the Permit Conditions or corresponding requirements set out under subsequent Environmental Permits issued for the whole Project.

3. Membership

- Chair** : The ENPC will be co-chaired by Civil Engineering and Development Department (Permit Holder of Environmental Permits No. EP-356/2009 and No. EP-376/2009) and Highways Department (Permit Holder of Environmental Permit No. EP-364/2009).
- Members** :
- (a) Engineer of the WDII project (WDII consultants).
 - (b) Engineer of the CWB project (CWB consultants).
 - (c) Engineer's Representative of the WDII works contracts.
 - (d) Engineer's Representative of the CWB works contracts.
 - (e) the Environmental Team (ET) Leader.
 - (f) the Independent Environmental Checker (IEC).
 - (g) the permit holders of the further EPs of the whole Project.
 - (h) the contractors of works contracts under the whole Project.
 - (i) representative of respective CLGs (representative to be appointed by CLGs).
- Secretaries** : RE/Environmental for the WDII works contracts and RE/Environmental for the CWB works contracts.

(version 1.5)

4. Operation of ENPC

4.1 ENPC Meetings

- (a) The ENPC will meet on monthly basis, or as required by the activities of the whole Project, or as requested by the ENPC. However, the frequency of the ENPC Meetings will be reconsidered when the majority of the works contracts under the whole Project are completed.
- (b) CEDD and HyD will chair the ENPC meeting alternatively.
- (c) The dates of the meetings will be determined at the ENPC meetings. Normally the monthly meetings will be held following the submission of the monthly EM&A Reports by the ET Leader to ensure that the most up to date information in respect of EM&A can be discussed at the meetings.
- (d) The ENPC Secretaries will take up the secretarial works for the ENPC meeting.
- (e) The secretaries will prepare the proposed meeting agenda and circulate it to members for comments prior to each ENPC meeting. The meeting agenda will contain the following major items :
 - Report on matters related to the EM&A by the ET Leader and the IEC.
 - Issues related to the CLG.
 - Specific environmental issues raised.
 - Review of actions from the previous meeting.

4.2 Communications

External communications of the ENPC shall be through the Chair.

5. Responsibilities

The ENPC is only to coordinate the actions by the respective parties to oversee and facilitate effective control of the cumulative environmental impacts arising from the multiple contracts for the construction of the whole Project. The decisions made or the actions agreed at the ENPC should not be considered as constituting instructions under individual works contracts of the whole Project. The Employers, the Engineers, the Engineer's Representatives, the ET Leader, and the IEC for individual works contracts shall carry out their own necessary contract administrative procedures for implementing the actions as agreed at the ENPC.

(version 1.7)

Community Liaison Groups (CLG) Set Up under Environmental Permits No. EP-356/2009, No. EP-364/2009 and EP-376/2009

1. Aim of CLG

1.1 Condition 2.4 of the Environmental Permits No. EP-356/2009, No. EP-364/2009 and No. EP-376/2009 (the EPs) stipulates that the Permit Holders shall set up a Community Liaison Group (CLG) comprising representatives from the relevant concerned and affected parties, including owners' corporations, management offices, local committees and schools of affected areas, including the North Point and Tin Hau areas, to facilitate communication, enquiries and complaints handling on all environmental issues, including the follow up on the implementation of remedial mitigation measures. The Permit Holders shall set up the CLG before the commencement of construction of the relevant component(s) of the WDII and CWB Project. A designated complaint hotline shall also be set up for the Project to address such concerns and complaints in an efficient manner. The detailed arrangements of the CLG shall be reported to the Environmental Project Committee (ENPC) and its activities be reflected as update in the EM&A Manuals for the Project.

1.2 Hence the CLG is set up to specifically meet the above requirements in Condition 2.4 of the EPs.

2. Terms of Reference

2.1 The role of CLG is consultative. It is set up to facilitate communication, enquiries and complaints handling on all environmental issues including the follow up on the implementation of remedial mitigation measures.

2.2 Specifically the CLG will meet regularly :

- (a) to provide a platform for the Permit Holders to communicate with the public to understand the construction activities of the Project and the associated environmental issues to the community;
- (b) to review the environmental concerns and complaints received from the public and to report any exceedence of limits observed; and
- (c) to review the follow-up on the implementation of remedial mitigation measures.

3. Setting-up CLGs

3.1 As the stakeholders for different parts of the project area are different, separate CLG will be formed for different areas to facilitate effective and efficient communication with the community. The following four CLGs will be formed :

- (a) North Point CLG for Highways Department's works contracts at North Point and covering the community of the North Point and Tin Hau areas.
- (b) Causeway Bay CLG for Highways Department's works contracts at Causeway Bay and covering the community of the Causeway Bay area.
- (c) Wan Chai CLG for Civil Engineering and Development Department's works contracts at

Wan Chai and covering the community of the Wan Chai area.

(version 1.7)

- (d) Central CLG for Highways Department's works contracts at Central and covering the community of the Central area.

The extent of the community to be invited to join each of the above CLGs will be determined by the relevant EP Holders and the Engineer's Representatives, taking into account the likely extents of the environmental impacts and the public liaison requirements.

4. Membership

- 4.1 Chair : The CLG will be chaired by the Engineer's Representatives of the CWB and WDII works contracts. (If there are more than one works contracts and hence more than one Engineer's Representatives, only one Engineer's Representative is to be assigned to chair one CLG.)
- 4.2 Members :
- (a) Engineer's Representatives for the works contracts.
 - (b) Environmental Team (ET) Leader.
 - (c) Independent Environmental Checker (IEC).
 - (d) representative from the relevant EP Holders and FEP Holders (including the persons responsible for public relation issues from the works contractors)
 - (e) the environmental consultants of WDII project and CWB project
 - (f) Representatives from District Offices will be invited to attend on as-needed basis.
 - (g) representatives from concerned stakeholders of the relevant community (as listed in Appendix A).
- 4.3 Secretaries : RE/Environmental (or RE/Public Liaison) for the works contracts.

*(version 1.7)***5. Operation of CLG****5.1 CLG Meetings**

- (a) The CLG will meet as required by the activities of the Project or by the request of the Chair.
- (b) Meeting notes will be taken and distributed by the CLG Secretaries.
- (c) The secretaries will prepare the proposed meeting agenda with agreement of the Chair prior to each CLG meeting. The meeting agenda will contain the following major items :
 - Updates on the Project and construction activities.
 - Specific environmental issues raised.
 - Review of the implementation of remedial mitigation measures.
 - Review of actions from the previous meeting.
- (d) The detailed arrangements of CLG shall be reported to ENPC.

(version 1.7)

Appendix A

Remarks:

1. The Owner's Corporations are deemed to be represented by their appointed management offices. If the Owner's Corporation prefers to be member of the CLG, it will replace the corresponding management office as the CLG member.
2. The lists below are to be updated in the course of the relevant works.

A. North Point CLG members from the community of the North Point and Tin Hau areas

Item	The Community	Address and Contact Telephone Number	Contact Person
1.	PLK Yu Lee Mo Fan Memorial school	19 Wharf Road, North Point, Hong Kong Tel :2566 3805	To be confirmed
2.	Hong Kong Baptist Church Henrietta Secondary School	2 City Garden Road, North Point, Hong Kong Tel :25701466	Mr. Dai
3.	Management Office of City Garden	9 City Garden Road, North Point, Hong Kong Tel :270 4584	Mr. Chin
4.	Harbour Grand Hong Kong	23 Oil Street, North Point, Hong Kong Tel :2121 2688	To be confirmed
5.	Management Office of Fu Lee Loy Mansion	9-27 King Wah Road, North Point, Hong Kong	To be confirmed
6.	Wan Wah Mansion	11-13 Oil Street, North Point, Hong kong	To be confirmed
7.	Wang Fa Mansion	2 Wang On Road, North Point, Hong Kong	To be confirmed
8.	Victor Court	14-28 Wang On Rd, North Point, Hong Kong	To be confirmed
9.	Causeway Bay Community Centre	7 Fook Yum Road, North Point, Hong Kong Tel :3104 2303	Ms. Emily Cheng
10.	Management Office of Harbour Heights	3 Fook Yum Road, North Point, Hong Kong	To be confirmed

(version 1.7)

Item	The Community	Address and Contact Telephone Number	Contact Person
11.	Management Office of Sea View Estate	29-41 Tong Chong Street Quarry Bay, Hong Kong	To be confirmed
12.	Management Office of Victoria Centre	15 Watson Road, Causeway Bay, Hong Kong	To be confirmed
13.	Management Office of Hoi Tao Building	3 King Ming Road, Causeway Bay, Hong Kong	To be confirmed
14.	Kam Tao Building	4 Whitfield Road, Causeway Bay, Hong Kong	To be confirmed
15.	Ngan Tao Building	8 Whitfield Road, Causeway Bay, Hong Kong	To be confirmed
16.	Management Office of Citicorp Centre	18 Whitfield Road, Causeway Bay, Hong Kong	To be confirmed
17.	Management Offices of Belle House	98 Hing Fat Street, Causeway Bay, Hong Kong	To be confirmed
18.	Whitfield Mansion	15-19 Whitfield Road, Causeway Bay, Hong Kong	To be confirmed
19.	Shun Hing Building	11-13 Whitfield Road, Causeway Bay	To be confirmed
20.	Hoi Sing Building	128-142 2nd Street, Sai Ying Pun – located at Kenny Town, to be further checked	To be confirmed
21.	Ming Hing Building	9-11 Gordon Road, Causeway Bay, Hong Kong	To be confirmed
22.	Management Office of Gordon House	62-86 Hing Fat Street Causeway Bay, Hong Kong	To be confirmed

(version 1.7)

Item	The Community	Address and Contact Telephone Number	Contact Person
23.	Management Office of Mayson Garden Building	1A-1B Tsing Fung Street, Causeway Bay, Hong Kong	To be confirmed
24.	Management Office Victoria Court	2A Tsing Fung Street, Causeway Bay, Hong Kong or 50-56 Hing Fat Street, Causeway Bay Hong Kong	To be confirmed
25.	Management Office of Viking Garden	40 Hing Fat Street, Causeway Bay, Hong Kong	To be confirmed
26.	Victoria Park School for the Deaf	36 Hing Fat Street, Causeway Bay, Hong Kong	To be confirmed
27.	Management Office of Park Towers	1 King's Road, Causeway Bay, Hong Kong	To be confirmed
28.	Operations Branch of Water Supplies Department	WSD Hong Kong Regional Building, 611 King's Road, North Point, Hong Kong	To be confirmed
29.	Harbour Grand Hong Kong	23 Oil Street, North Point, Hong Kong	To be confirmed
30.	Management Office of Provident Centre	23 Wharf Road, North Point, Hong Kong	To be confirmed
31.	Management Office of King Wah House	5-7 King Wah Road, North Point, Hong Kong	To be confirmed

(version 1.7)

Item	The Community	Address and Contact Telephone Number	Contact Person
32.	FEHD Whitfield Depot	AECOM Asia Co. Ltd. at 12th Floor, Grand Central Plaza, Tower 2 138 Sha Tin Rural Committee Road Sha Tin, New Territories, Hong Kong or Public Relations Unit, Headquarters 5th floor, Ho Man Tin Government Offices 88 Chung Hau Street Ho Man Tin, Kowloon.	Mr. Charlton Wong

(version 1.7)

B. Causeway Bay CLG members from the community of the Causeway Bay area

Item	The Community	Address and Contact Telephone Number	Contact Person
1.	Management Offices of Prospect Mansion	66-72 Paterson Street, Causeway Bay	To be supplemented
2.	Management Offices of Welcome Mansion	58-64 Paterson Street, Causeway Bay	To be supplemented
3.	Management Offices of Towing Mansion	50-56 Paterson Street, Causeway Bay	To be supplemented
4.	Management Offices of Causeway Bay Mansion	42-48 Paterson Street, Causeway Bay	To be supplemented
5.	Management Offices of Miami Mansion	13-15 Cleveland Street, Causeway Bay	To be supplemented
6.	Management Offices of Florida Mansion	9-11 Cleveland Street, Causeway Bay	To be supplemented
7.	Management Offices of Cleveland Mansion	5-7 Cleveland Street, Causeway Bay	To be supplemented
8.	Management Offices of Hamilton Mansion	1-3 Cleveland Street, Causeway Bay	To be supplemented
9.	Management Offices of Highland Mansion	8 Cleveland Street, Causeway Bay	To be supplemented
10.	Management Offices of Marco Polo Mansion	10 Cleveland Street, Causeway Bay	To be supplemented
11.	Management Offices of Newtown Mansion	6 Cleveland Street, Causeway Bay	To be supplemented
12.	Management Offices of Victoria Park Mansion	15 Kingston Street, Causeway Bay	To be supplemented
13.	Management Offices of Clarke Mansion	9 Kingston Street, Causeway Bay	To be supplemented
14.	Management Offices of Chesterfield Mansion	11 Kingston Street, Causeway Bay	To be supplemented
15.	Management Offices of Riviera Mansion	59-65 Paterson Street, Causeway Bay	To be supplemented
16.	Management Offices of Haywood Mansion	57 Paterson Street, Causeway Bay	To be supplemented
17.	Management Offices of Vienna Mansion	55 Paterson Street, Causeway Bay	To be supplemented

(version 1.7)

Item	The Community	Address and Contact Telephone Number	Contact Person
18.	Management Offices of Hyde Park Mansion	53 Paterson Street, Causeway Bay	To be supplemented
19.	Management Offices of Fairview Mansion	51 Paterson Street, Causeway Bay	To be supplemented
20.	Excelsior Hong Kong	281 Gloucester Road, Causeway Bay	To be supplemented
21.	World Trade Centre	280 Gloucester Road, Causeway Bay	To be supplemented
22.	Management Office of Windsor House	311 Gloucester Road, Causeway Bay	To be supplemented
23.	Management Office of Hoi Deen Court	276-279 Gloucester Road, Causeway Bay	To be supplemented
24.	Management Office of Hoi Tao Court	271-275, Gloucester Road, Causeway Bay	To be supplemented
25.	Management Office of Hoi Kung Court	264-269 Gloucester Road, Causeway Bay	To be supplemented
26.	Top Glory Tower	262 Gloucester Road, Causeway Bay	To be supplemented
27.	Sino Plaza	256-257 Gloucester Road, Causeway Bay	To be supplemented
28.	Management Office of Elizabeth House	250-254 Gloucester Road, Causeway Bay	To be supplemented
29.	Royal Hong Kong Yacht Club	Royal Hong Kong Yacht Club, Causeway Bay	To be supplemented
30.	Police Officers' Club	Police Officers' Club, Causeway Bay	To be supplemented
31.	Operations Branch of Water Supplies Department	Hong Kong and Islands Regional Office WSD Hong Kong Regional Building 611 King's Road, North Point Tel: 2880 2555	CE/HK Mr Yeung Sek Kui

(version 1.7)

Item	The Community	Address and Contact Telephone Number	Contact Person
32.	Hong Kong Transport, Logistics & Management Co. Ltd	Administration Building Cross-Harbour Tunnel Hungghom, Kowloon, Hong Kong	To be supplemented
33.	Causeway Bay Typhoon shelter Mutual Aid Committee	To be confirmed	To be supplemented
34.	Hong Kong Cargo-Vessel Traders' Association Limited	2/F, 21-23 Man Wai Building, Man Cheong Street	To be supplemented
35.	Hong Kong Pilots Association	1601-1606, Hong Kong Plaza, 186-191 Connaught Road West, Hong Kong.	To be supplemented
36.	Owners of temporary structures at CBTS	To be confirmed	To be supplemented
37.	香港漁民近岸作業協會	Rm 1209, Sui Yick hse, Siu Sai Wan Est, Chai Wan Tel: 9088 8728	Mr. Lai Tai Hei
38.	銅鑼灣廟船	To be confirmed	To be supplemented
39.	海上業界聯席會議	To be confirmed	To be supplemented
40.	港九電船拖輪商會	46 & 48 Man Cheong Bldg., 3/F., Ferry Point, Kowloon, Hong Kong .	To be supplemented
41.	海上遊覽業聯會	Rm 1615, One Grand Tower, 639 nathan Rd, Mong Kok Tel: 9484 5417	張有光

(version 1.7)

C. Wan Chai CLG members from the community of the Wan Chai area

Item	The Community	Address and Contact Telephone Number	Contact Person
1	Hong Kong Convention and Exhibition Centre (Management) Ltd	Tel.: 2582 7070	P K Chan
2	Kiu Lok Service Management Co. Ltd.	Room 1108, Office Tower, Convention Plaza, 1 Harbour Road, Wan Chai Tel: 2802 7966	Mr. C. K. Wu
3	Management Office of the Hong Kong Academy for Performing Arts	1 Gloucester Road, Wan Chai Tel: 2584 8500	Mr. Joseph Law
4	Management Office of Hong Kong Arts Centre	2 Harbour Road Tel.:2584 8690	Mr. Kwok
5	Management Office of Shui On Centre	Room 102, 1/F, Shui On Centre, 6-8 Harbour Road, Hong Kong Tel: 2879 1803	Ms. Eva Wong
6	Management Office of Sun Hung Kai Centre	26/F., Sun Hung Kai Centre, 30 Harbour Road, Wan Chai Tel: 2828 5218	Mr. Ricky Kwan
7	Management Office of Great Eagle/Harbour Centre	Suite 3206, Great Eagle Centre, 23 Harbour Road, Wan Chai Tel: 2879 2118 (for Great Eagle Centre) 26/F., Sun Hung Kai Centre, 30 Harbour Road, Wan Chai Tel: 2828 0852 (for Harbour Centre)	Ms. Polly Lo Mr. S. C. Ip
8	Management Office of China Resources Building	Room 4206-10, 42/F., China Resources Building, 26 Harbour Road, Hong Kong Tel: 2828 5688	Mr. Dave Law
9	Management Office for Convention Plaza Apartments	Convention Plaza Apartments, 1 Harbour Road, Wan Chai Tel.: 2829 7098	Mr. George Lau
10	Telecom House (managed by REACH)	19 th Floor, Telecom House, 3 Gloucester Road, Wan Chai Tel: 2983 3719	Mr. Herrick Chong

(version 1.7)

Item	The Community	Address and Contact Telephone Number	Contact Person
11	Grand Hyatt Hong Kong Hotel	1 Harbour Road Hong Kong Tel.:2584 7021	Mr. Kwong
12	Renaissance Harbour View Hotel	1 Harbour Road, Wanchai Tel.:2802 8888	Ms. Siu
13	Management Office of Central Plaza	Suite 2802, 28/F, Central Plaza 18 Harbour Road, Wanchai, Hong Kong Tel.:2586 8111	To be confirmed
14	Society for the Prevention of Cruelty to Animals Hong Kong, SPCA(HK)	5, Wan Shing Street, Wan Chai Tel.: 2232 5516	Ms. Leung
15	Management Office of Causeway Bay	Block A, Causeway Centre 28 Harbour Road, Wan Chai	To be confirmed
16	ECO gas station at Wan Shing Street	To be confirmed	To be confirmed
17	Operations Branch of Water Supplies Department	To be confirmed	To be confirmed
18	Representative of EMSD (for the operation of the seawater cooling system for the government offices at Wan Chai North)	Electrical and Mechanical Services Department 3 Kai Shing Street, Kowloon, Hong Kong Tel: 3155 4304	Mr. Ernest Li
19	Representative of LCSD (for the operation of the Wan Chai Sports Ground)	Tel.:2827 7720	Ms. Mabel Chan

D. Central CLG members from the community of the Central area

Item	The Community	Address and Contact Telephone Number	Contact Person
1.	IFC	1 Harbour View Street	To be supplemented
2.	Four Seasons Hotel Hong Kong and Four Seasons Place	8 Finance Street, Central	To be supplemented
3.	Management Offices of the Bauhinia (Korea Centre)	119-120 Connaught Rd Central, Sheung Wan	To be supplemented

Appendix L
Sketch A for Enhanced Water Quality
Monitoring and Audit Programme

C6 AND C7: EXISTING SEAWATER INTAKE

--- : ODOR PATROL ROUTES FOR CONSTRUCTION PHASE

● : MONITORING STATION FOR DO MEASUREMENT FOR CONSTRUCTION PHASE

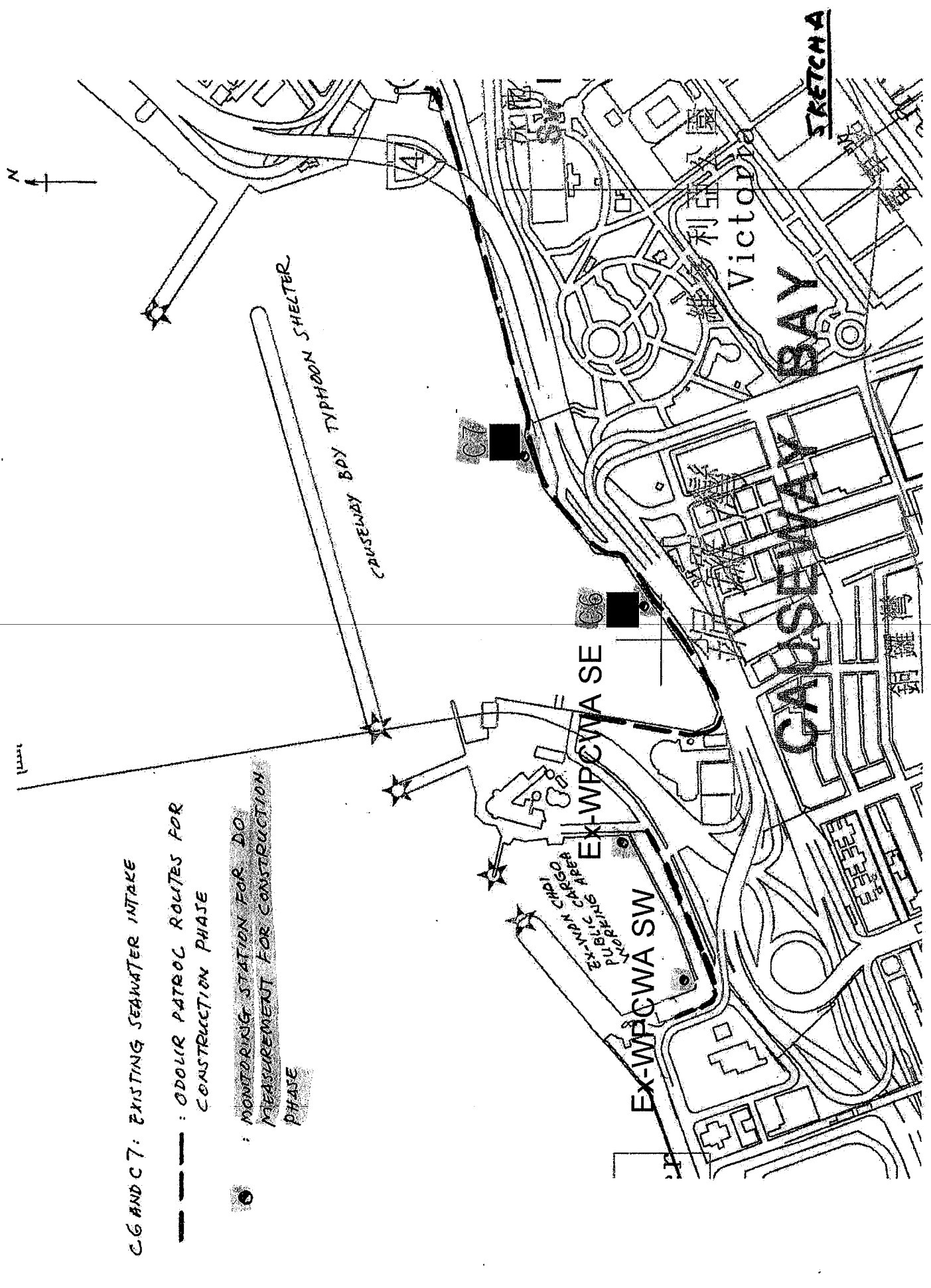

Appendix M
Proposal for Real-time
Noise Monitoring System



CONTRACT NO: HK/2009/05

**WANCHAI DEVELOPMENT PHASE II AND
CENTRAL WANCHAI BYPASS
SAMPLING, FIELD MEASUREMENT AND TESTING
WORK (STAGE 1)**

**PROPOSAL ON THE REAL-TIME NOISE
MONITORING SYSTEM**

CLIENTS:

**Civil Engineering and Development
Department**

and

Highways Department

PREPARED BY:

Lam Geotechnics Limited

11/F Centre Point
181-185 Gloucester Road,
Wanchai, H.K.

Telephone: (852) 2882-3939

Facsimile: (852) 2882-3331

E-mail: info@lamenviro.com

Website: <http://www.lamenviro.com>

CHECKED BY:

Raymond Dai
Environmental Team Leader

DATE:

2 July 2010



Proposal on the Real-time Noise Monitoring System

1. Introduction

According to Condition 2.5(c) of EP-356/2009 and Condition 2.5(b) and EP-364/2009, a real-time on-site monitoring system of the noise level around the works sites shall be set up at North Point and Tin Hau areas during the construction phase. This proposal presents the details of system configuration and installation details for the real time on site monitoring system.

2. Equipments

Component equipments of the real-time noise monitoring are listed below. Details of equipments are as follows. Specifications of proposed equipments are shown in **Appendix A**.

- Bruel & Kjaer Handheld Analyzer 2250 Light Model no. 2250-L-400 (Hand-held Analyzer with Sound Level Meter Software BZ-7130, logging software BZ-7133 and Utility Software for Hand-held Analyzers, BZ-5503);
- Bruel & Kjaer outdoor microphone kit UA-1404;
- Sound Level Calibrator
- 3m Microphone Extension Cable
- Rechargeable battery for power supply;
- Wireless modem (GPS or equivalent mechanism)
- Weatherproof Cabinet; and
- Equipment power converter for battery 12V to 5V (if necessary)
- Rechargeable battery (12V, 50AH) for location where a/c supply cannot be obtained (From supplier information, 12V battery can supply normally 30-40days in this real-time noise monitoring set-up and the battery condition could be indicated by the screen of SLM.)
- Weatherproof Cabinet of approximate dimension (roughly 0.25m X 0.4m X 0.5m) to house all the necessary equipment

3. Proposed Monitoring Stations

The proposed real-time noise monitoring stations for EP- 356/2009 and EP-364/2009 are summarized as below. The proposed locations of monitoring stations are enclosed in **Appendix B**.

Table 3.1 Summary of the proposed monitoring stations

EP	District	Monitoring Location	Measurement Type	Commencement of Monitoring
EP-356/2009	Tin Hau	Tung Lo Wan Fireboat Station	Façade Measurement	Land-based pilling and filling works
	North Point	Oil Street Community Liaison Centre	Free-field Measurement	Land-based pilling and filling works



EP	District	Monitoring Location	Measurement Type	Commencement of Monitoring
EP-364/2009	Tin Hau	Tung Lo Wan Fireboat Station	Façade Measurement	CWB Pilling works
		Causeway Bay Community Centre	Façade Measurement	IECL Bridge Demolition
	North Point	Oil Street Community Liaison Centre	Free-field Measurement	IECL Bridge Demolition
		Hong Kong Baptist Church Henrietta Secondary School	Free-field Measurement	IECL Bridge Demolition

For free-field measurement at Oil Street Community Liaison Centre and Hong Kong Baptist Church Henrietta Secondary School, additional 3dB(A) shall be made on the measured results.

4. Set-up Monitoring Stations

- The sound level meter, GSM modem, power converter and rechargeable battery should be stored inside the weatherproof cabinet to protect from sunlight and rain.
- Rechargeable battery and Converter should be provided for the power supply of the sound level meter and wireless modem.
- Outdoor microphone kit UA-1404 is a weather-proof microphone and suitable for semi-permanent, unsupervised outdoor installation. It is effective to protect the microphone from wind, rain, chemical resistant and birds during the real-time noise monitoring.
- Outdoor microphone should be mounted a mast connects to the sound level meter inside weatherproof cabinet. The mast shall be mounted on parapet wall at the premise. Schematic drawing of the monitoring equipments and proposed locations of monitoring stations are enclosed in **Appendix B**.

5. Methodology

- Liaison with the appropriate Noise Sensitive Receivers (NSRs) at North Point and Tin Hau to set up a real time on site noise monitoring on their premise.
- After obtained approval from the NSR, setting-up of equipments on-site shall be prior to the commencement of construction phase as stated in **Table 3.1**.
- Testing and commissioning of the stations shall be conducted for at least 14 works days before the commencement of the monitoring station.
- The on-site monitoring system shall be automatically conducted for 24 hours a day.
- Noise level shall be measured in term of the A-weighted equivalent continuous sound pressure level L_{eq} . $L_{eq(30min)}$ shall be used as the monitoring parameter for the time period between 0700-1900 hrs in normal weekdays. $L_{eq(5min)}$ shall be used for the measurement during all days during 1900 – 0700 hrs and general holiday 0700 – 2300 hrs.
- As supplementary information for data auditing, L_{10} and L_{90} shall be also obtained for reference.
- The noise data shall be transmitted through GSM wireless communication or equivalent device to head office computer server by mobile dial up mechanism (Relevant information is shown in **Appendix A**).



- h) The data shall be audited within two working days of sampling and audited data shall be posted onto EM&A website for public access two working days after sampling
- i) Calibration check of sound level meter shall be conducted once every two weeks. Laboratory calibration of sound level meters and calibrator shall be conducted annually.
- j) For public safety, the microphone extension shall be disassembled upon the hoisting of typhoon signal No. 3 or above and no data shall be captured until the microphone is re-assembled when the typhoon signal is removed. Moreover, it is not sensible to capture noise data during the typhoon period as the data are not representative.
- k) Regular checking of monitoring stations and renew rechargeable battery shall be maintained at least every two weeks so as to keep the consistency of the real time noise monitoring.

6. Compliance Checking of Noise Data

- a) In order to avoid the erroneous noise data, background noise shall be studied before the commencement of the construction works as described in **Table 3.1**.
- b) For the review of background noise, it is recommended to obtain 14 days during the period of non-construction hours for both non-restricted hours and restricted hours. The non-constructed hours are defined as the time without any construction works near the monitoring station. The duration of selected time periods for the comparison and elimination of background noise from measured noise level is shown as **Table 6.1**. The measured noise levels obtained in these periods will be compared with the background noise level of the same period obtained during the non-construction hours. The actual non-construction hours will be determined with the Contractor works programme.

Table 6.1 Duration of selected periods for comparison

Time Periods	Period for Non-constructed Hours
Non-restricted hours	0700-1000hrs (normal weekdays)
	1000-1700hrs (normal weekdays)
	1700-1900hrs (normal weekdays)
Restricted hours	1900-2300hrs (all days)
	2300-0700hrs (all days)
	0700-1900hrs (Sunday and Public Holiday)

- c) The duration and parameter of background noise shall be in term of $L_{eq(30min)}$ during the period of 0700-1900 hours on normal weekday and $L_{eq(5min)}$ during the period other than 0700-1900 hours on normal weekday. It shall be as a factor to eliminate the background noise from the measured noise level.
- d) Compliance checking of the corrected noise level shall be applied to the normal construction hours 0700-1900 hrs between Monday and Saturday.
- e) It shall be also applied to the restricted hour if any construction works conducted with valid CNP during this period.



- f) In case of any action and limit level exceedances occur, the exceeded noise level will be analysed and reviewed any relationship with the construction works. Shall the non-compliance occurs, action shall be taken in accordance with the Event/Action Plan stipulated in EM&A Manual.



APPENDIX A

SPECIFICATIONS OF PROPOSED EQUIPMENTS

PRODUCT DATA

2250 Light – with Sound Level Meter Software BZ-7130
Optional Software: 1/1-oct. Frequency Analysis BZ-7131,
1/3-oct. Frequency Analysis BZ-7132 and Logging BZ-7133

2250 Light has been developed specifically for measuring occupational, environmental and product noise, while complying fully with all the relevant national and international standards.

Extensive user studies have been paired with state-of-the-art technology to make this analyzer a robust, effective and elegant tool for those applications.

Using the large, high contrast, touch screen interface, the analyzer can easily be set up to display and measure just what is needed from the extensive list of parameters provided by the analyzer.

2250 Light comes with Sound Level Meter Software installed, measuring all parameters simultaneously within its wide 120 dB dynamic range. For frequency analysis, add the 1/1- and/or 1/3-octave software module. For time profile investigation, add the Logging software module. The optional software modules install easily and work seamlessly with the Sound Level Meter Software.

Back in the office, USB connectivity lets you use your PC to archive, manage, view or even control 2250 Light, as well as export your results to software packages such as Microsoft® Excel and Brüel & Kjær Types 7815, 7820 or 7825 for post-processing and reporting.



Uses and Features

USES

- Environmental noise assessment, monitoring and complaints
- Occupational noise evaluation
- Selection of hearing protection
- Noise reduction
- Product quality control
- General purpose Class 1 sound measurements
- Real-time analysis of sound in 1/1- and 1/3-octave bands
- Analysis of time histories for broadband parameters and spectra (Logging)

FEATURES

- Large, high-resolution, touch-sensitive screen
- 'Traffic Light' status indicator
- Plug-in rechargeable Li-ion battery
- Data storage on plug-in memory cards
- 120 dB dynamic range – up to 140 dB
- Real-time frequency analysis in 1/1-octave bands
- Real-time frequency analysis in 1/3-octave bands
- Broadband and spectrum logging
- Logging profile display with markers
- Back-erase to delete unwanted noise events
- PC software included for archiving, export and reporting
- Robust and environmentally protected (IP 44)
- Upgrade to Type 2250 on exchange basis

Introduction

2250 Light combines renowned Brüel & Kjær measurement excellence and the Type 2250 platform's ease of use, in an efficient and versatile sound measurement instrument. Whether you are addressing workplace noise compliance, environmental noise assessment, or product noise certification, 2250 Light offers the functionality to meet your requirements. A unique user-interface makes your measurements easier to perform with results that are easier to analyze and report.

This data sheet describes the suite of software applications available for 2250 Light. All instruments come with the Sound Level Meter Software for 2250 Light (BZ-7130) included.

Note: 2250 Light can be upgraded to a Type 2250 Hand-held Analyzer, to include more features and applications such as advanced logging, sound recording or reverberation time software. Please refer to Type 2250 Product Data BP 2025 for more information. The upgrade is on an exchange basis, please contact your local Brüel & Kjær representative for details.

Applications

Workplace and Industrial Hygiene Noise Measurement Applications

2250 Light was developed with special interest for the measurement of workplace noise. The comfortable and secure design feels safe in your hand. With the display located relatively close to you, the buttons fall precisely where they need to be for a one thumb operated Start, Stop and Save. The 'Traffic Light' indicator surrounding the Start/Pause pushbutton gives you an immediate visual indication of measurement status – even in the brightest sunshine. The large, high contrast, touch screen/display, lets you select parameters on the display, and 2250 Light can memorise those setups for your next measurement.



As for occupational health noise parameters, nothing was left out. 2250 Light can measure Fast and Slow, A-weighted and C-Weighted SPLs simultaneously, along with a separately weighted peak detector, so that the values you need to specify hearing protection are immediately on the display. Parallel analysis allows you to compare a 3 dB exchange rate average measurement with a selectable alternate 4, 5 or 6 dB exchange rate, including separate dose, expected dose and exposure values.

2250 Light also offers three independent threshold peak event counters, along with simultaneous Fast, Slow and Impulse RMS detectors, to assess impulsive noise.

When you add the optional 1/1-octave frequency analysis software option, you are ready to instantly assess noise control and detailed hearing protection requirements for a surveyed location. With 2250 Light there is no filter switching, or range changing, all the octaves are measured at the same instant, along with the broadband A- and C-weighted values. For even more detail, add the 1/3-octave frequency analysis option. Instantly see the maximum and average levels across 31 frequency bands spanning three decades from 12.5 Hz to 16 kHz.

Sometimes noise levels in the workplace vary dramatically, and perhaps irregularly. To assess this kind of noise it is helpful to measure and analyse a noise profile – a measurement that shows how the sound varies with time.

The Logging option for 2250 Light provides this capability in a naturally intuitive way, using simultaneous views of the complete profile and a ‘zoomed-in’ 100-second ‘window’. Set up to five different user-defined markers anywhere in the profile, to identify noise sources or events. If you have installed either the 1/1- or 1/3-octave real-time frequency analysis options, 2250 Light seamlessly integrates the spectrum information into the noise profile.

Back at your desk after a survey, or even a single measurement, archive the measurements using the included utility program, where you can view all the results of your measurement on a Windows® compatible PC. Use the same utility program to transfer measurement results to Excel to easily produce reports, or export the results directly to Brüel & Kjær’s Protector Type 7825, where you can organise and analyze the company’s noise and hearing conservation program. Type 7825 calculates noise exposure according to ISO 9612.2.

So, whether you are making a simple noise survey, or supplementing noise dose measurements for noise control or hearing protection selection, 2250 Light is an easy, yet powerful tool to make you more productive, and more confident in analysing hearing conservation programs.

Environmental Noise Measurement Applications

The tasks for environmental noise measurements are varied, so the instrument you pick for your measurements needs to be flexible, easy to configure, powerful and accurate. 2250 Light is all that, and more, making it ideal for a simple noise enforcement measurement one moment, then a complex environmental impact survey the next. 2250 Light is built on the core platform of the award winning design of Type 2250. It borrows the robust construction, intuitive touch screen interface, and legendary Brüel & Kjær measurement accuracy.



2250 Light with the standard Sound Level Meter software (BZ-7130) is ideal for a spot noise enforcement check. Use the large numeric display, press the conveniently located Start pushbutton, and when ready, press the same button to stop the measurement. Press the Save pushbutton, and you will not only be saving the results, but also the actual time of the measurement, its duration, and even the date and time for the last calibration of the instrument.

2250 Light can measure all the parameters needed for environmental noise, including dual frequency weightings, Fast, Slow, and Impulse Time Averaging, L_{eq} 's and a full range of statistical distributions. But just as important, you can set 2250 Light to display just the parameters you need, then save that display so 2250 Light powers-up, tailor-made for your use, every time.

For more involved environmental applications, you'll need to add the Logging option. Now you can set the instrument to record all, or up to ten selected measurement results at intervals from one second to one day, for a duration only limited by the size of the CF or SD memory card used in the external memory slots. The display offers two simultaneous views, one of

the complete profile and a 'zoomed-in' 100-second 'window', that are intuitively linked by the cursor.

For the precise timing of noise events, an alternative 'Fast Log' view gives you either or both of the L_{AF} and L_{Aeq} results for 100 ms intervals. In either the fast log, or profile view, you can define up to five different markers anywhere in the profile, to identify noise sources or events. When you use the real-time frequency analysis options, 1/1-octave or 1/3-octave, the frequency spectrum average, maximum and minimum values can be logged along with the overall values. Save and view the noise profiles on your Windows® PC with the included utility program, or for easy analysis of the noise profile, export the whole measurement to Brüel & Kjær Environmental Noise Software (Type 7820 Evaluator or Type 7821 Evaluator Light) which have built-in calculation algorithms that allow you to produce compound sound level figures from several contributions. Some may have impulse or pure tone penalties, depending on which measurement standard you choose, for example, ISO 1996, DIN 45 645, TA Lärm, NF S 31-010, or BS 4142. (See Product Data BP 1752.)

You'll take these measurements with the incredible 120 dB dynamic range of 2250 Light, allowing measurements from the low noise floor of the instrument to over 140 dB. Without a range switch to consider, you can now make measurements without fear of overload, and still capture the nuances of a silent night. 2250 Light is an ideal entry point to safe, easy and precise environmental noise measurements.

Product Noise Measurement

Brüel & Kjær long ago set the standard for product noise measurements. Now, whether you have a simple A-weighted sound limit requirement, or need to evaluate a 1/3-octave reverberation chamber sound power test, 2250 Light is scalable to your requirements.



2250 Light can be used as a hand-held device for easy portability, or it can be operated using your Windows® PC as an on-line USB controlled device in your laboratory. The user-defined templates make switching between applications easy.

The wide 120 dB dynamic range of 2250 Light eliminates concern for overloads, and you can set a preset measurement time to add consistency to your measurements. Use the built-in headphone style (3.5 mm) output jack to send the signal out to other measurement instrumentation. The included utility program makes it easy to keep track of results in an organised, archive structure. And, of course, there's the Class 1 precision and reputation of Brüel & Kjær, giving you and your customers' complete confidence in your measurements, while adding value to your products.

For comprehensive data management and post-process reporting, consider using 2250 Light data together with Type 7815 Noise Explorer, which supports a wide range of user-definable graphic and tabular displays.

Graphs and tables can be imported into standard Windows® applications such as word processors and spreadsheets.

Fig. 1 Key features of 2250 Light



060202

Fig. 2
The large numeric display - ideal for a spot noise enforcement check

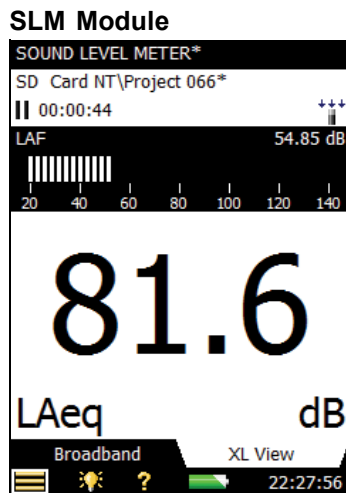

2250 Light comes with the Sound Level Meter Software for 2250 Light included. This makes 2250 Light into a versatile broadband sound level meter; it complies with the latest international standard (IEC 61672-1) as well as previous international and national standards.

All quantities are measured at the same time. For example, A and C frequency weighted levels are measured simultaneously, and at the same time F, S and I time weightings are applied in parallel. In addition, Peak levels are measured. Full statistics are also computed on-the-fly. Combine this with the dynamic range exceeding 120 dB and you will never miss a beat! You get all the parameters in one attempt, under-range is non-existent and you will have difficulties provoking an overload.

A full compliment of occupational health sound parameters are provided simultaneously, complying with national and international standards. The detailed list of available parameters can be found in the specifications section. You choose what you want on the display, but, at any time – during or after the measurement – all other parameters can be inspected and reported.

1/1- and 1/3-octave Frequency Analysis Software for 2250 Light – BZ-7131 and BZ-7132

Fig. 3
Example of 1/1-octave frequency analysis. Note that two spectra are displayed simultaneously

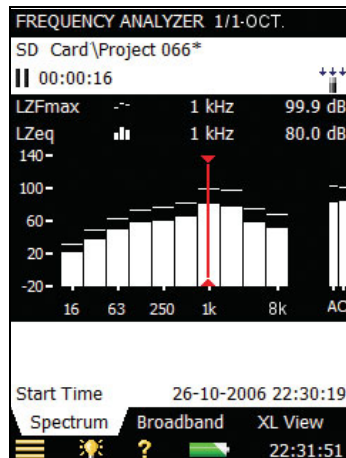

1/1-octave Frequency Analysis Software for 2250 Light BZ-7131, and 1/3-octave Frequency Analysis Software for 2250 Light BZ-7132 are optional software modules. They allow you to make real-time measurements in 1/1- or 1/3-octave bands over a wide frequency range. This makes it a simple matter to obtain spectra in order to, for example, select hearing protection, qualify heat and ventilation systems, and assess tonality.

The following frequency ranges are available:

- 1/1-octave spectra (centre frequencies 16 Hz to 8 kHz)
- 1/3-octave spectra (centre frequencies 12.5 Hz to 16 kHz)

In each band you have a full and unrivalled dynamic range from the noise floor in that particular band to 140 dB. That is, a dynamic range generally in excess of 135 dB.

Spectra can be A-, B-, C- or Z-weighted. Five spectra are measured and stored and, in addition, two instantaneous spectra are available for display. Two spectra, for example, a minimum and maximum spectrum, can be superimposed on the display. All the broadband quantities measured by Sound Level Meter Software BZ-7130 are computed in parallel with the frequency analysis.

Logging Software for 2250 Light – BZ-7133

Fig. 4
Display showing part of
a logging profile and an
exclude marker

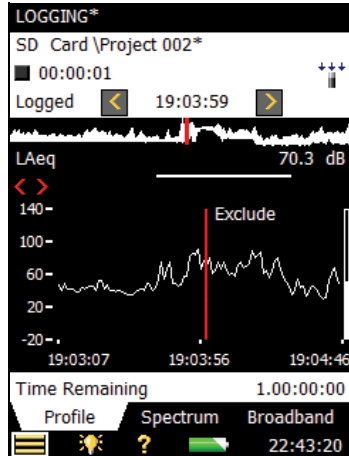

With the optional Logging Software enabled, 2250 Light becomes a versatile instrument for obtaining time histories. The Logging Software allows you to select freely among the broadband parameters and log them at intervals from 1 s to 24 h. At the same time L_{Aeq} and/or L_{AF} can be logged at 100 ms intervals.

If Frequency Analysis Software BZ-7131 or BZ-7132 is enabled, the Logging Software additionally lets you log spectra at the same 1 s to 24 h intervals.

Logging Software BZ-7133 incorporates a number of features designed to make difficult field work as manageable as possible.

Among the most salient of these features are the following:

- Five user-definable markers can be set on-the-fly in the profile. Use these, for example, to clearly indicate specific noise sources or events
- Markers can be set directly on the profile display using the stylus and the touch screen. Simply ‘tap and drag’ on the part of the profile you want to mark and select a marker from the drop-down list
- Three of the markers can also be set using the three marker pushbuttons
- Markers can even be set ‘after the fact’. The display covers the latest 100 samples (that is, 100 s of profile when logging at 1 s intervals, otherwise more) meaning that in most cases you can wait for the event (or disturbance) to stop before placing your marker. Alternatively, scroll back in the profile and set your marker
- Lets you browse easily between markers
- The profile display can be ‘frozen’ at any time (this happens automatically when you tap the screen), allowing you to work at ease

All markers are saved with the measurement, see Fig. 4. No further bookkeeping is required. When exporting data to, for example, 7821 Evaluator Light software for further analyses, markers are directly accessible on the profile.

Data is stored directly on SD or CF cards; for availability, please refer to the Ordering Information. Data can be directly read from the memory card by the included PC software BZ-5503 (see following section). This means that even large amounts of data can be quickly transferred to a PC.

In order to give an indication of the amount of memory required, some examples have been listed below. Values should be compared to the standard size of the SD cards used, which start at 128 Mbyte.

For convenience, values for 1 s logging periods during 24 h are given. Other values easily compute from these:

- Five broadband parameters, no statistics: 1 Mbyte
- All broadband parameters, one 100 ms parameter: 3 Mbyte
- All broadband parameters, no statistics: 4 Mbyte
- All broadband parameters, one 100 ms parameter, all 1/3-octave spectra: 30 Mbyte
- All broadband parameters with full statistics: 58 Mbyte
- All broadband parameters, one 100 ms parameter, all 1/3-octave spectra, full statistics: 86 Mbyte

Type 2250 PC Software – Utility Software for Hand-held Analyzers BZ-5503

Utility Software for Hand-held Analyzers BZ-5503 is an archiving tool for 2250 Light data and setups, and functions as the link between 2250 Light and post-processing or reporting software on a PC. It enables you to do the following:

- Control 2250 Light from a PC
- Manage and archive data on a PC
- Keep your 2250 Light software up to date



Overview of 2250 Light Software Features

The table that follows presents a summary of the features of each of the software modules available with 2250 Light. See Specifications for details.

Feature	SLM Software (Included)	1/1-octave Frequency Analysis Software	1/3-octave Frequency Analysis Software	Logging Software
120+ dB Dynamic Range – no need for range switching	•	•	•	•
Sound levels up to 140 dB with supplied Microphone Type 4950	•	•	•	•
IEC/ANSI SLM standards Type/Class 1	•	•	•	•
Frequency weightings A, B, C, Z (linear) and time weightings F, S, I	•	•	•	•
Free-field/diffuse-field correction	•	•	•	•
Pre-set time start/stop	•	•	•	•
Back-erase – last 5 seconds of measurement data	•	•	•	
Multi-language user interface	•	•	•	•
Context-sensitive help	•	•	•	•
Broadband statistics based on L_{Aeq} , L_{AF} or L_{AS}	•	•	•	•
Broadband frequency range: 5 Hz – 18 kHz	•	•	•	•
Remote control using Analogue or GSM modem	•	•	•	•
Transfer of data files while measuring (USB or modem)	•	•	•	•
1/1-octave spectra (centre frequencies 16 Hz to 8 kHz)		•		• ^a
1/3-octave spectra (centre frequencies 12.5 Hz to 16 kHz)			•	• ^a
Logging of all or selected broadband parameters and spectra				•
Logging period 1 s to 24 h				•
L_{Aeq} and/or L_{AF} logged every 100 ms				•
Profile display				•
Profile overview of entire measurement				•
Markers on profile display				•

a. If 1/1- or 1/3-octave Frequency Analysis Software is enabled

Compliance with Standards

 	CE-mark indicates compliance with the EMC Directive and Low Voltage Directive. C-Tick mark indicates compliance with the EMC requirements of Australia and New Zealand.
Safety	EN/IEC 61010-1: Safety requirements for electrical equipment for measurement, control and laboratory use. UL 61010B-1: Standard for Safety – Electrical measuring and test equipment.
EMC Emission	EN/IEC 61000-6-3: Generic emission standard for residential, commercial and light industrial environments. CISPR 22: Radio disturbance characteristics of information technology equipment. Class B Limits. FCC Rules, Part 15: Complies with the limits for a Class B digital device. IEC 61672-1, IEC 61260, IEC 60651 and IEC 60804: Instrumentation standards
EMC Immunity	EN/IEC 61000-6-2: Generic standard – Immunity for industrial environments. EN/IEC 61326: Electrical equipment for measurement, control and laboratory use – EMC requirements. IEC 61672-1, IEC 61260, IEC 60651 and IEC 60804: Instrumentation standards

Specifications – 2250 Light Platform

Specifications apply to 2250 Light fitted with Microphone Type 4950 and Microphone Preamplifier ZC-0032

SUPPLIED MICROPHONE

Type 4950: Prepolarized Free-field ½" Microphone
Nominal Open-circuit Sensitivity: 50 mV/Pa (corresponding to -26 dB re 1 V/Pa) ±2 dB
Capacitance: 12.5 pF (at 250 Hz)

MICROPHONE PREAMPLIFIER ZC-0032

Nominal Preamplifier Attenuation: 0.3 dB
Connector: 10-pin LEMO
Extension Cables: Up to 100 m in length between the microphone preamplifier and 2250 Light, without degradation of the specifications

SELF-GENERATED NOISE LEVEL

Typical values at 23°C for nominal microphone open-circuit sensitivity:

Weighting	Microphone	Electrical	Total
"A"	14.0 dB	12.9 dB	16.4 dB
"B"	12.9 dB	11.8 dB	15.4 dB
"C"	13.0 dB	13.4 dB	16.2 dB
"Z" 5 Hz–20 kHz	14.4 dB	19.2 dB	20.4 dB

KEYBOARD

Pushbuttons: 11 keys with backlight, optimised for measurement control and screen navigation

ON-OFF BUTTON

Function: Press 1 s to turn on; press 1 s to enter standby; press for more than 5 s to switch off

STATUS INDICATORS

LEDs: Red, amber and green

DISPLAY

Type: Transflective back-lit touch screen 240 × 320 dot matrix
Black and White Scheme
Backlight: Adjustable level and on-time

USER INTERFACE

Measurement Control: Using pushbuttons on keyboard
Setup and Display of Results: Using stylus on touch screen or pushbuttons on keyboard
Lock: Keyboard and touch screen can be locked and unlocked

USB INTERFACE

USB 1.1 OTG Mini B socket

MODEM INTERFACE

Hayes compatible GSM or standard analogue modems connected through the Compact Flash slot

INPUT SOCKET

Connector: Triaxial LEMO
Input Impedance: ≥ 1 MΩ
Direct Input: Max. input voltage: ±14.14 V_{peak}

HEADPHONE SOCKET

Connector: 3.5 mm Minijack stereo socket
Max. Peak Output Level: ± 1.4 V
Output Impedance: 32 Ω in each channel

EXTERNAL DC POWER SUPPLY REQUIREMENTS

Used to charge the battery pack in the instrument
Voltage: 8–24 VDC, ripple voltage < 20 mV
Current Requirement: min. 1.5 A
Power Consumption: < 2.5 W, without battery charging, < 10 W when charging
Cable Connector: LEMO Type FFA.00, positive at centre pin

BATTERY PACK

Type: Li-Ion rechargeable
Typical Operating Time: > 8 hours

STORAGE SYSTEM

Internal Flash-RAM (non-volatile): 20 Mbyte for user setups and measurement data
External Secure Digital Memory Card (SD-card): For store/recall of measurement data
External Compact Flash Memory Card (CF-card): For store/recall of measurement data

CLOCK

Back-up battery powered clock. Drift < 0.45 s per 24 hour period

WARM-UP TIME

From Power Off: < 2 minutes
From Standby: < 10 seconds

TEMPERATURE

IEC 60068-2-1 & IEC 60068-2-2: Environmental Testing. Cold and Dry Heat
Operating Temperature: -10 to +50°C (14 to 122°F), < 0.1 dB
Storage Temperature: -25 to +70°C (-13 to +158°F)

HUMIDITY

IEC 60068-2-78: Damp Heat: 90% RH (non-condensing at 40°C (104°F)).
Effect of Humidity: < 0.1 dB for 0% < RH < 90% (at 40°C (104°F) and 1 kHz)

MECHANICAL

Environmental Protection: IP 44
Non-operating:
IEC 60068-2-6: Vibration: 0.3 mm, 20 m/s², 10–500 Hz
IEC 60068-2-27: Shock: 1000 m/s²
IEC 60068-2-29: Bump: 4000 bumps at 400 m/s²

WEIGHT AND DIMENSIONS

650 g (23 oz.) including rechargeable battery
300 × 93 × 50 mm (11.8 × 3.7 × 1.9") including preamplifier and microphone

LANGUAGE

User Interface in Catalan, Croatian, Czech, Danish, English, Flemish, French, German, Hungarian, Japanese, Italian, Polish, Portuguese, Romanian, Serbian, Slovenian, Spanish, Swedish and Turkish

HELP

Concise context-sensitive help in Catalan, English, French, German, Italian, Japanese, Polish, Portuguese, Romanian, Serbian, Slovenian and Spanish

Software Specifications – Sound Level Meter Software for 2250 Light BZ-7130

Conforms with the following National and International Standards:

- IEC 61672–1 (2002–05) Class 1
- IEC 60651 (1979) plus Amendment 1 (1993–02) and Amendment 2 (2000–10), Type 1
- IEC 60804 (2000–10), Type 1
- IEC 61252, Electroacoustics – Specifications for Personal Sound Exposure Meters
- DIN 45657 (1997–07)
- ANSIS1.4–1983 plus ANSI S1.4A–1985 Amendment, Type 1
- ANSIS1.43–1997, Type 1

Note: The International IEC Standards are adopted as European standards by CENELEC. When this happens, the letters IEC are replaced with EN and the number is retained. 2250 Light also conforms to these EN Standards

CORRECTION FILTERS

For Microphone Type 4950:

Correct the frequency response to compensate for sound field and accessories:

Sound Field: Free-field or Diffuse-field

Accessories: None, Windscreen UA-0237

DETECTORS

Parallel Detectors on every measurement:

A- or B-weighted (switchable) broadband detector channel with three exponential time weightings (Fast, Slow, Impulse), one linearly averaging detector and one peak detector

C- or Z-weighted (switchable) as for A- or B-weighted

Overload Detector: Monitors the overload outputs of all the frequency weighted channels

MEASUREMENTS

X = frequency weightings A or B

Y = frequency weightings C or Z

V = frequency weightings A, B, C or Z

U = time weightings F or S

Q = exchange rate 4, 5 or 6 dB

N = number between 0.1 and 99.9

For Storage

Full statistics

For Display and Storage

Start Time	Stop Time	Overload %
Elapsed Time	L_{XE}	L_{Yeq}
L_{XE}	L_{YE}	$L_{Ceq-L_{Aeq}}$
L_{XSmax}	L_{XFmax}	L_{XImax}
L_{YSmax}	L_{YFmax}	L_{YImax}
L_{XSmin}	L_{XFmin}	L_{XImin}
L_{YSmin}	L_{YFmin}	L_{YImin}
L_{Xleq}	L_{Yleq}	$L_{Aleq-L_{Aeq}}$
L_{AFTeq}	$L_{AFTeq-L_{Aeq}}$	Time Remaining
$L_{ep,d}$	$L_{ep,d,v}$	E
Dose%	Proj. Dose%	#VPeaks (>NNNdB)
#VPeaks (>137dB)	#VPeaks (>135dB)	L_{Vpeak}
T_{Vpeak}	L_{avUQ}	TWA
TWA_v	DoseUQ%	Proj. DoseUQ%

Only for Display as Numbers or Quasi-analogue Bars

L_{XS}	L_{XF}	L_{XI}
L_{YS}	L_{YF}	L_{YI}
$L_{XS(SPL)}$	$L_{XF(SPL)}$	$L_{XI(SPL)}$
$L_{YS(SPL)}$	$L_{YF(SPL)}$	$L_{YI(SPL)}$
$L_{Vpeak,1s}$	L_{AN1} or L_{AUN1}	L_{AN2} or L_{AUN2}
L_{AN3} or L_{AUN3}	L_{AN4} or L_{AUN4}	L_{AN5} or L_{AUN5}
L_{AN6} or L_{AUN6}	L_{AN7} or L_{AUN7}	

MEASURING RANGES

Dynamic Range: From typical noise floor to max. level for a 1 kHz pure tone signal, A-weighted: 16.4 to 140 dB

Primary Indicator Range: In accordance with IEC 60651, A-weighted: 23.9 dB to 123 dB

Linearity Range: In accordance with IEC 60804, A-weighted: 21.8 dB to 140 dB

Linear Operating Range: In accordance with IEC 61672, A-weighted: 1 kHz: 25.0 dB to 140 dB

Peak C Range: In accordance with IEC 61672: 30.1 dB to 143 dB

SAMPLING FOR BROADBAND STATISTICS

The Statistics can be based on either L_{AF} , L_{AS} or L_{Aeq} :

- Statistics L_{AFN1-7} or L_{ASN1-7} are based on sampling L_{AF} or L_{AS} , resp., every 10 ms into 0.2 dB wide classes over 130 dB
- Statistics L_{AN1-7} are based on sampling L_{Aeq} every second into 0.2 dB wide classes over 130 dB

Full distribution saved with measurement

MEASUREMENT DISPLAYS

SLM: Measurement data displayed as numbers of various sizes and one quasi-analogue bar

Measured data are displayed as dB values, housekeeping data as numbers in relevant format.

Instantaneous measurement L_{XF} is displayed as a quasi-analogue bar

MEASUREMENT CONTROL

Manual: Manually controlled single measurement

Automatic: Pre-set measurement time from 1 s to 24 hours in 1 s steps

Manual Controls: Reset, Start, Pause, Back-erase, Continue and Store the measurement manually

BACK-ERASE

The last 5 s of data can be erased without resetting the measurement

MEASUREMENT STATUS

On Screen: Information such as overload and running/paused are displayed on screen as icons

Traffic Lights: Red, yellow and green LEDs show measurement status and instantaneous overload as follows:

- Yellow LED flash every 5 s = stopped, ready to measure
- Green LED flashing slowly = awaiting calibration signal
- Green LED on constantly = measuring
- Yellow LED flashing slowly = paused, measurement not stored
- Red LED flashing quickly = intermittent overload, calibration failed

CALIBRATION

Initial calibration is stored for comparison with later calibrations

Acoustic: Using Sound Calibrator Type 4231 or custom calibrator.

The calibration process automatically detects the calibration level when Sound Calibrator Type 4231 is used

Electrical: Uses internally generated electrical signal combined with a typed-in value of microphone sensitivity

Calibration History: Up to 20 of the last calibrations made are listed and can be viewed on the instrument

SIGNAL MONITORING

The input signal can be monitored using an earphone/headphones connected to the headphone socket

Headphone Signal: Input signal can be monitored using this socket with headphones/earphones

Gain Adjustment: –60 dB to 60 dB

DATA MANAGEMENT

Project Template: Defines the display and measurement setups

Project: Measurement data stored with the Project Template

Job: Projects are organised in Jobs

Explorer facilities for easy management of data (copy, cut, paste, delete, rename, view data, open project, create job, set default project name)

PREFERENCES

Date, Time and Number formats can be specified

Software Specifications – 1/1-octave Frequency Analysis Software for 2250 Light BZ-7131 and 1/3-octave Frequency Analysis Software for 2250 Light BZ-7132

The specifications for BZ-7131 and BZ-7132 include the specifications for Sound Level Meter Software for Light BZ-7130. BZ-7131 and BZ-7132 add:

STANDARDS

Conforms with the following National and International Standards:

- IEC 61260 (1995–07) plus Amendment 1 (2001–09), 1/1-octave Bands, Class 0
- ANSIS1.11–1986, 1/1-octave Bands and 1/3-octave Bands, Order 3, Type 0–C
- ANSIS1.11–2004, 1/1-octave Bands, Class 0

CENTRE FREQUENCIES

1/1-octave Band Centre Frequencies (BZ-7131 only):

16 Hz to 8 kHz

1/3-octave Band Centre Frequencies (BZ-7132 only):

12.5 Hz to 16 kHz

MEASUREMENTS

X = frequency weightings A, B, C or Z

Spectra for Display and Storage

L_{Xeq} L_{XSmax} L_{XFmax}
 L_{XSmin} L_{XFmin}

Spectra for Display Only

L_{XS} L_{XF}

Single Values

SIL PSIL SIL3
 L_{Aeq} (20-200 Hz) (BZ-7132 only)

MEASURING RANGES

Dynamic Range: From typical noise floor to max. level for a pure tone signal at 1 kHz 1/3-octave: 1.5 to 140 dB

Linear Operating Range: In accordance with IEC 61260: ≤ 20.5 dB to 140 dB

MEASUREMENT DISPLAYS

Spectrum: One or two spectra superimposed + A/B and C/Z broadband bars

Table: One or two spectra in tabular form

Y-axis: Range: 5, 10, 20, 40, 60, 80, 100, 120, 140 or 160 dB. Auto zoom or auto scale available

Cursor: Readout of selected band

Software Specifications – Logging Software for 2250 Light BZ-7133

The specifications for BZ-7133 include the specifications for Sound Level Meter Software for 2250 Light BZ-7130. BZ-7133 adds:

MEASUREMENTS

Logging: Measurement data logged at pre-set periods into files on external SD- or CF-cards

Logging Period: From 1 s to 24 hours with 1 s resolution

Fast Logging: L_{AF} and L_{Aeq} can be logged every 100 ms, irrespective of logging period

Broadband Data Stored at each Logging Interval: All, or up to 10 selectable broadband data

Broadband Statistics Stored at each Logging Interval: Full distribution, or none

Spectrum Data Stored at each Logging Interval: All, or up to 3 selectable spectra (license for BZ-7131 or BZ-7132 required)

Logging Time: From 1 second to 31 days with 1 s resolution

Measurement Total: For the logging time, in parallel with logging: All broadband data, statistics and spectra (license for BZ-7131 or BZ-7132 required)

Automatic reboot and resume of operation in case of power failure

MARKERS

Five user-definable markers for on-line marking of noise sources or events anywhere in the profile.

Markers are set using the stylus on the touch screen, or the three marker pushbuttons

MEASUREMENT DISPLAYS

Profile: Graphical display of selectable measurement data versus time. Fast display of next or previous marker, Profile Overview of entire measurement

Y-axis: Range: 5, 10, 20, 40, 60, 80, 100, 120, 140 or 160 dB. Auto zoom or auto scale available

X-axis: Scroll facilities

Cursor: Readout of measurement data at selected time

STORAGE

Measurement data is stored on an external SD or CF memory card. For availability, please refer to the Ordering Information

Software Specifications – Utility Software for Hand-held Analyzers BZ-5503

BZ-5503 is included with 2250 Light for easy synchronisation of data between PC and 2250 Light. BZ-5503 is supplied on CD-ROM BZ-5298

ON-LINE DISPLAY OF 2250 LIGHT DATA

Measurements on 2250 Light can be controlled from the PC and displayed on-line with the PC, using the same user interface on the PC as on 2250 Light

DATA MANAGEMENT

Explorer: Facilities for easy management of Instruments, Jobs and Projects (copy, cut, paste, delete, rename, create)

Data Viewer: View measurement data (content of projects)

Synchronisation: Projects can be synchronised between PC and 2250 Light

EXPORT FACILITIES

Excel: Projects (or user specified parts) can be exported to Microsoft® Excel

Type 7810/12/15/16/20/25: Projects can be exported to Predictor Type 7810, Lima Type 7812, Noise Explorer Type 7815, Acoustic Determinator Type 7816, Evaluator Type 7820 or Protector Type 7825

2250 LIGHT SOFTWARE UPGRADES AND LICENSES

The utility software controls 2250 Light software upgrades and licensing of the 2250 Light applications

INTERFACE TO 2250 LIGHT

USB ver. 1.1 or Hayes compatible GSM or standard analogue modem

PC REQUIREMENT

Operating System: Windows® 2000/Windows® XP, Microsoft® .NET
Recommended PC: Pentium® III (or equivalent) processor, 128 Mbyte RAM, SVGA graphics display/adaptor, sound card, CD ROM drive, mouse, USB, Windows® XP

Ordering Information

2250 LIGHT PACKAGES

Type 2250-L-100	Hand-held Analyzer with Sound Level Meter Software BZ-7130
Type 2250-L-200	Hand-held Analyzer with Sound Level Meter Software BZ-7130 and 1/1-octave Frequency Analysis Software BZ-7131
Type 2250-L-300	Hand-held Analyzer with Sound Level Meter Software BZ-7130, 1/1-octave Frequency Analysis Software BZ-7131 and 1/3-octave Frequency Analysis Software BZ-7132
Type 2250-L-400	Hand-held Analyzer with Sound Level Meter Software BZ-7130 and Logging Software BZ-7133
Type 2250-L-500	Hand-held Analyzer with Sound Level Meter Software BZ-7130, 1/1-octave Frequency Analysis Software BZ-7131, 1/3-octave Frequency Analysis Software BZ-7132 and Logging Software BZ-7133

SOFTWARE MODULES AVAILABLE SEPARATELY

BZ-7131	1/1-octave Frequency Analysis Software for 2250 Light
BZ-7132	1/3-octave Frequency Analysis Software for 2250 Light
BZ-7133	Logging Software for 2250 Light

COMPONENTS INCLUDED WITH TYPE 2250-L

Type 4950	Prepolarized Free-field 1/2" Microphone
ZC-0032	Microphone Preamplifier
AO-1476	USB Standard A to USB Mini B Interface Cable, 1.8 m (6 ft)
BZ-5298	Environmental Software, including BZ-5503 Utility Software for Hand-held Analyzers
ZG-0429	Mains Power Supply
QB-0061	Battery Pack Stylus

BASIC KIT FOR 2250 LIGHT (UA-1703)

FB-0691	Hinged Cover for Hand-held Analyzer
UA-0237	90 mm dia. Windscreens
DH-0696	Wrist Strap
KE-0441	Protective Cover for 2250 Light
UA-1654	5 Extra Styli

PLUS KIT FOR 2250 LIGHT (UA-1704)

FB-0691	Hinged Cover for Hand-held Analyzer
UA-0254	90 mm dia. Windscreens (6 pack of UA-0237)
UA-1673	Adaptor for Standard Tripod Mount
DH-0696	Wrist Strap
KE-0441	Protective Cover for 2250 Light
HT-0015	Earphones
UA-1654	5 Extra Styli
Type 4231	Sound Calibrator
UA-1251	Lightweight Tripod
UL-1009	SD Memory Card

ADVANCED KIT FOR 2250 LIGHT (UA-1705)

FB-0691	Hinged Cover for Hand-held Analyzer
UA-0254	90 mm dia. Windscreens (6 pack of UA-0237)
UA-1673	Adaptor for Standard Tripod Mount
DH-0696	Wrist Strap

TRADEMARKS

Microsoft and Windows are registered trademarks of Microsoft Corporation in the United States and/or other countries · Pentium is a registered trademark of Intel Corporation or its subsidiaries in the United States and/or other countries

Brüel & Kjær reserves the right to change specifications and accessories without notice.

HEADQUARTERS: DK-2850 Nærum · Denmark · Telephone: +45 4580 0500
Fax: +45 4580 1405 · www.bksv.com · info@bksv.com

Australia (+61) 2 9889-8888 · Austria (+43) 1 865 74 00 · Brazil (+55) 11 5188-8161
Canada (+1) 514 695-8225 · China (+86) 10 680 29906 · Czech Republic (+420) 2 6702 1100
Finland (+358) 9-755 950 · France (+33) 1 69 90 71 00 · Germany (+49) 421 17 87 0
Hong Kong (+852) 2548 7486 · Hungary (+36) 1 215 83 05 · Ireland (+353) 1 807 4083
Italy (+39) 0257 68061 · Japan (+81) 3 5715 1612 · Republic of Korea (+82) 2 3473 0605
Netherlands (+31) 318 55 9290 · Norway (+47) 66 77 11 55 · Poland (+48) 22 816 75 56
Portugal (+351) 21 4169 040 · Singapore (+65) 6377 4512 · Slovak Republic (+421) 25 443 0701
Spain (+34) 91 659 0820 · Sweden (+46) 33 225 622 · Switzerland (+41) 44 8807 035
Taiwan (+886) 2 2502 7255 · United Kingdom (+44) 14 38 739 000 · USA (+1) 800 332 2040

Local representatives and service organisations worldwide

KE-0441	Protective Cover for 2250 Light
HT-0015	Earphones
UA-1654	5 Extra Styli
Type 4231	Sound Calibrator
UA-1251	Lightweight Tripod
UL-1009	SD Memory Card
Type 7821	Evaluator Light

OCCUPATIONAL HEALTH KIT FOR 2250 LIGHT (UA-1706)

FB-0691	Hinged Cover for Hand-held Analyzer
UA-0254	90 mm dia. Windscreens (6 pack of UA-0237)
UA-1673	Adaptor for Standard Tripod Mount
DH-0696	Wrist Strap
KE-0441	Protective Cover for 2250 Light
HT-0015	Earphones
UA-1654	5 Extra Styli
Type 4231	Sound Calibrator
UA-1251	Lightweight Tripod
UL-1009	SD Memory Card
Type 7825	Protector

ACCESSORIES AND COMPONENTS AVAILABLE SEPARATELY

ANALYZER

ZG-0444	Charger for QB-0061 Battery Pack
---------	----------------------------------

CALIBRATION

Type 4231	Sound Calibrator (fits in KE-0440)
2250-CAI	Accredited Initial Calibration of Type 2250
2250-CAF	Accredited Calibration of Type 2250
2250-CTF	Traceable Calibration of Type 2250
2250-TCF	Conformance Test of Type 2250, with certificate

MEASURING

Type 3592	Outdoor Measuring Gear (see Product Data BP 1744)
AO-0441-D-030	Microphone Extension Cable, 10-pin LEMO, 3 m (10 ft)
AO-0441-D-100	Microphone Extension Cable, 10-pin LEMO, 10 m (33 ft)
KE-0440	Travel Bag
UA-0587	Tripod
UA-0801	Small Tripod
UA-1317	Microphone Holder
UA-1651	Tripod Extension for Hand-held Analyzer
UL-1009	SD Memory Card for Hand-held Analyzers
UL-1013	CF Memory Card for Hand-held Analyzers
UA-1654	5 Extra Styli

INTERFACING

Type 7815	Noise Explorer – data viewing software
Type 7821	Evaluator Light – data viewing and calculation software
Type 7825	Protector – software for calculation of Personal Noise Exposure

SERVICE PRODUCTS

2250-L-EW1	Extended Warranty, one year extension
2250-L-MU1	Upgrade of 2250 Light to Type 2250, performed at headquarters

Brüel & Kjær 



PRODUCT DATA

Outdoor Microphone Unit — Type 4198 Outdoor Microphone Kit — UA-1404

Type 4198 is a weather-proof microphone and preamplifier assembly that meets IEC 61672 class 1 and ANSI S1.4 Type 2 specifications. Use it in any situation where you must make precise outdoor sound measurements.

Type 4198 is even suitable for semi-permanent, unsupervised outdoor installation.

Outdoor Microphone Kit UA-1404 includes all of the protective features of Type 4198, but without the microphone and preamplifier. It enables you to weather-proof your Falcon™ range microphones and preamplifiers. It can also protect the microphones and preamplifiers for Sound Level Meters Types 2236, 2250 and 2260. All recommended combinations fulfil IEC 61672 class 1 and ANSI S1.4 Type 2 specifications (see configuration diagram, Fig. 7).

Both the unit and the kit enable you to take measurements that are protected against the effects of wind, rain, and perching birds.



USES AND FEATURES

USES

- IEC 61672 class 1 compliant outdoor sound measurements in all weather conditions
- Unattended, semi-permanent outdoor installations
- Noise control
- Complaint investigations
- Research

FEATURES

- Protected against the effects of wind, rain, and perching birds
- Easy acoustic calibration

- Detailed free-field corrections on mini CD to obtain flat response in all sound fields
- Falcon™ range product with a 3-year guarantee
- UA-1404 usable with existing Falcon™ range microphones and preamplifiers

TYPE 4198 ALSO FEATURES

- Built-in Type 1 microphone and preamplifier
- Wide dynamic range: 15.2 dB(A) to 146 dB
- Remote calibration monitoring using CIC
- Individual microphone calibration charts
- Easy connection to standard measurement microphone equipment

Effective Protection in Outdoor Environments

Both Outdoor Microphone Unit Type 4198 and Outdoor Microphone Kit UA-1404 use the same protective assembly.

Effective Wind Protection

The windscreen reduces wind noise by approximately 15 dB for wind speeds up to 120 km/h. It is made of a specially prepared porous polyurethane foam, which is resistant to corrosive atmospheres and immune to moisture.

Effective Rain Protection

A rain cover protects the microphone from moisture. The cover surrounds the microphone cartridge inside the wind screen (see Fig. 5). It is specially designed to minimise its effect on the frequency and directional characteristics of the assembly.

Chemical resistant

All essential components are made of stainless steel to withstand tough environments.

Support and Protection

The windscreen is supported by three stainless steel rods that also protrude as rubber-capped spikes, which prevent birds from perching on the microphone. Each of the bird spikes is capped with soft rubber to make them easier to see and to help prevent eye injuries (see Fig. 5).

Fig. 1
The wind and rain cover can be removed easily, but not accidentally. This exposes the microphone for easy calibration

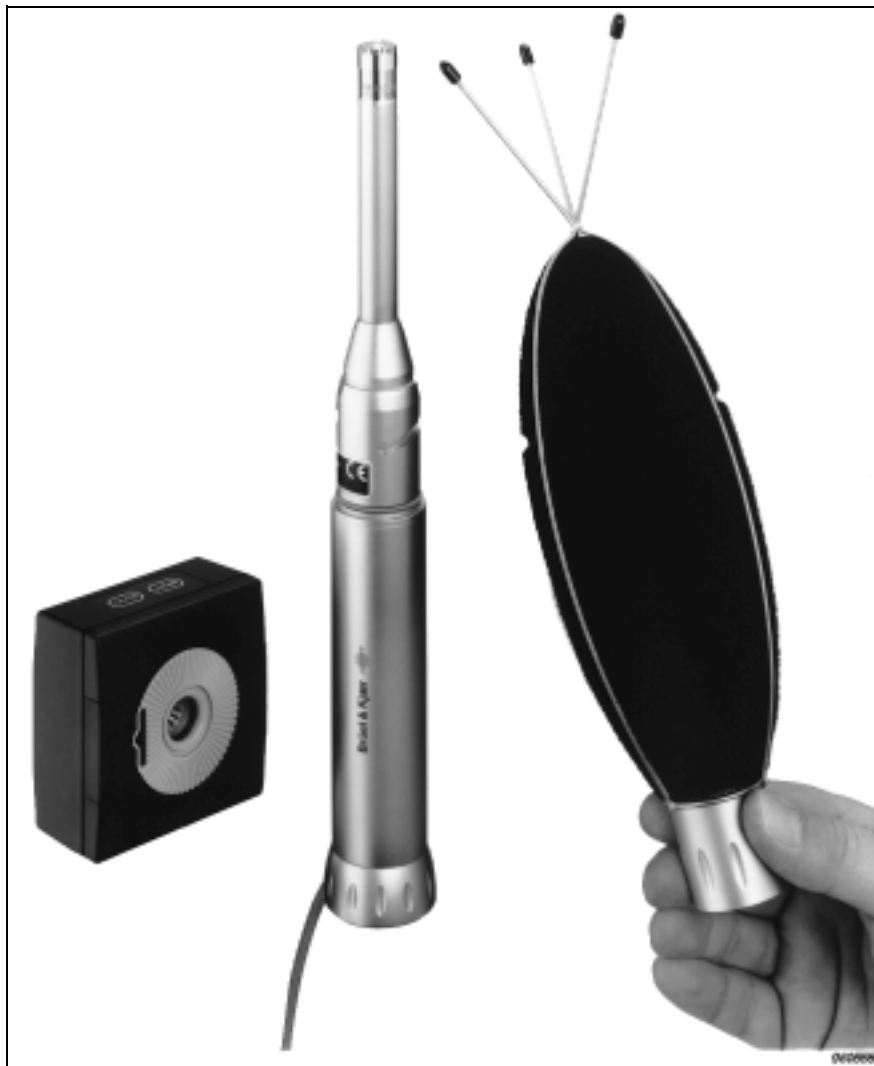

Long Lasting

The unit provides excellent long-term mechanical stability. Should the frame become bent or the foam worn-out, replacements are available.

Easy Acoustic Calibration

Many all-weather microphone systems provide durability at the expense of microphone accessibility, which makes acoustical calibration difficult. With Type 4198 and UA-1404, the windscreen and rain cover assembly can easily be removed, thus exposing the microphone for easy acoustical calibration (see Fig. 5).

Fig. 2
Frequency response of Outdoor Microphone Unit Type 4198. IEC 61672 class 1 tolerances are shown above and below the response curve

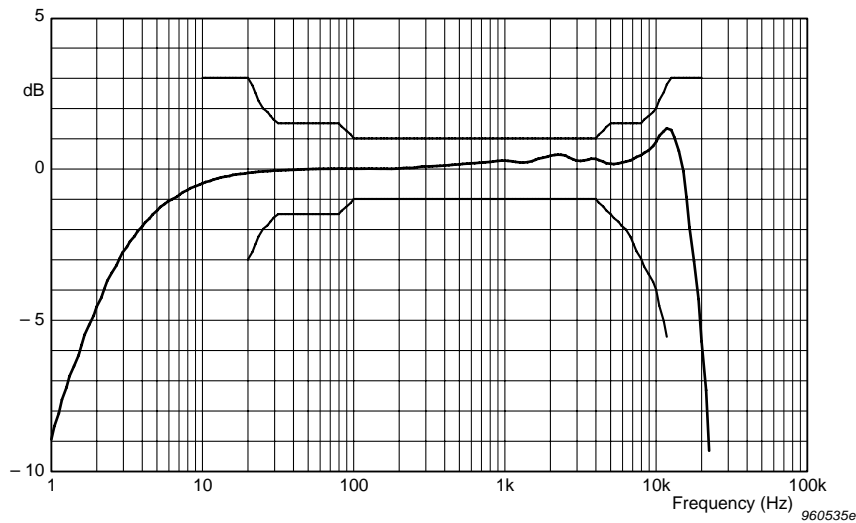

Fig. 3
Change in frequency response of Type 4188 microphone with Outdoor Microphone Kit UA-1404 (including the effect of the replacement grid)

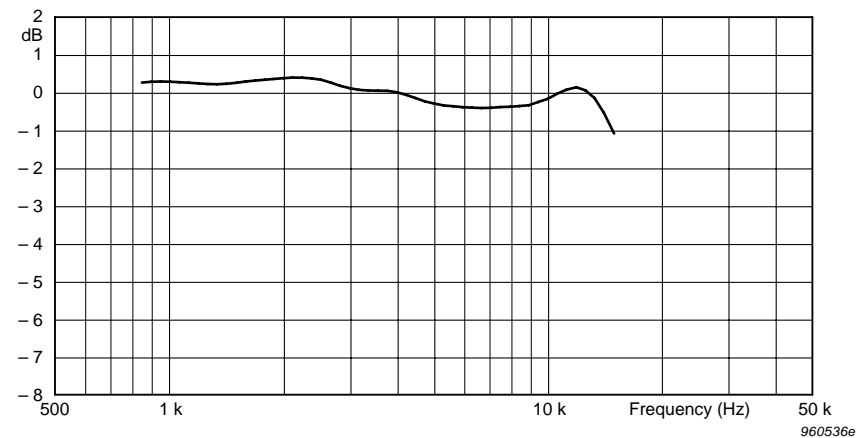
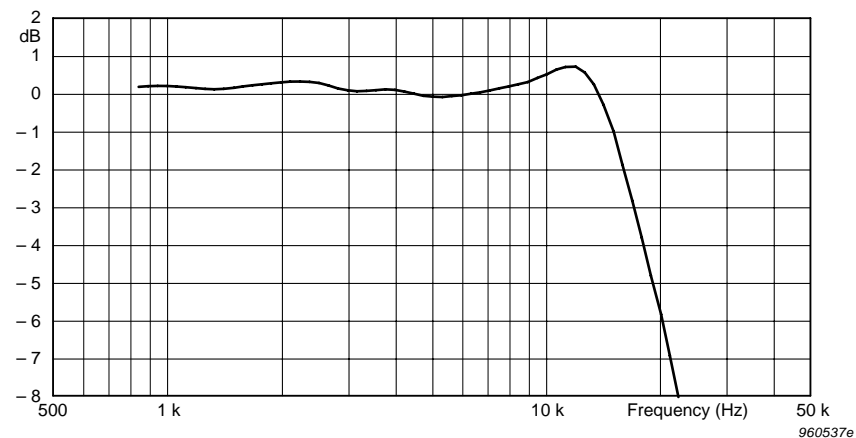
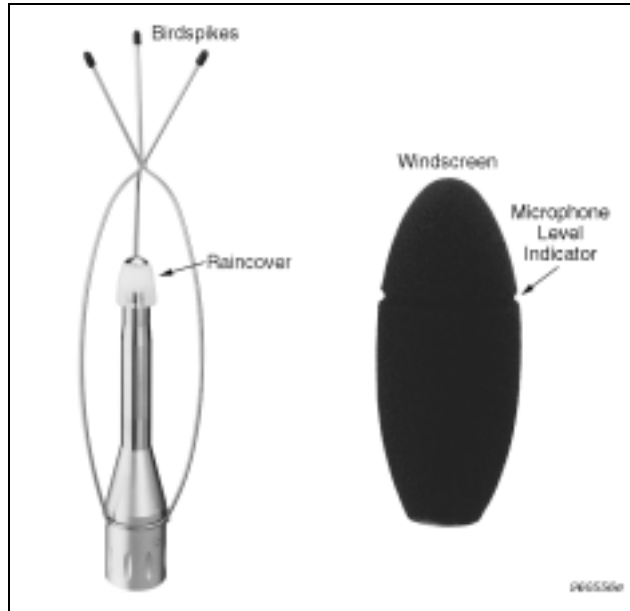

Fig. 4
Change in frequency response of Types 4189 and 4190 microphones with Outdoor Microphone Kit UA-1404 (including the effect of the replacement grid)



Unattended Outdoor Monitoring

Fig. 5
The weather protection components of Type 4198 and UA-1404



All of the features of Type 4198 and UA-1404 combine to create an assembly that can safely be installed for semi-permanent outdoor sound measurement. The assembly will maintain consistent performance even when left unattended in bad weather for several weeks.

Precise Microphone Placement

The height of the microphone inside the windscreen is clearly marked by the groove moulded into the screen (see Fig. 5).

Type 4198 — The Complete Outdoor Microphone

Precision Components

Outdoor Microphone Type 4198 includes the following components:

- Falcon Range Prepolarized Free-field 1/2" Microphone Type 4189
- Falcon Range 1/2" Microphone Preamplifier Type 2669-C
- Outdoor Microphone Kit UA-1404
- 10 meter extension cable AO-0414-D-100

Type 1 Microphone Cartridge

The Type 4198 includes a Falcon Range Prepolarized Free-field 1/2" Microphone Type 4189. Type 4189 is a rugged microphone that ensures high stability under a variety of conditions. Its stainless steel alloy diaphragm withstands even polluted industrial environments.

During manufacturing, each microphone is artificially aged at a high temperature to ensure good long-term stability.

Type 1 Preamplifier

Falcon Range Preamplifier Type 2669-C operates over a wide range of temperatures, humidity levels and other environmental conditions. Type 2669-C is especially well-suited for outdoor monitoring because of its ability to work with very long cables. It provides an extremely wide frequency and dynamic range with low noise.

Save Time and Expense with CIC

Brüel & Kjær's patented Charge Injection Calibration (CIC) facility is built into the preamplifier. It enables you to remotely monitor the microphone system for impedance changes, which can indicate a need for recalibration or repair. This will extend the period between acoustical

calibrations, thus saving you time and expense. For more information about CIC, see the Brüel & Kjær Microphone Handbook (BA 5105).

Individual Calibration

Each unit comes with individual calibration charts and a mini CD containing detailed free-field corrections to the actuator response. The corrections are supplied as comma separated ASCII text files.

Obtain Flat Response in All Fields

The information contained on the mini CD enables you to make extremely precise free-field measurements. When you are performing detailed frequency analysis, this information will enable you to adjust your readings to obtain a flat microphone response in any sound field.

Use Your Existing Equipment Outdoors with UA-1404

Outdoor Microphone Kit UA-1404 includes all of the weather protection equipment of Outdoor Microphone Type 4198 (windscreen, rain cover, bird spikes, and stainless steel enclosure). The kit is compatible with the following Brüel & Kjær equipment:

- Falcon Range Microphone Types 4188, 4189, and 4190
- Falcon Range Preamplifier Types 2671 and 2669-B/L/C
- Microphone and preamplifier from Hand-held Analyzer Type 2250
- Microphone and preamplifier from Sound Analyzer Type 2260
- Microphone and preamplifier from Sound Level Meter Type 2236 (see “Type 2236 Considerations” below)

The kit will enable you to use your existing equipment to make outdoor measurements, even unattended or in bad weather.

The kit includes two stainless steel 1/2" replacement microphone grids, which are required to obtain the correct frequency response. One is for use with microphone Type 4188 and the other for Types 4189 and 4190. They also help protect your microphone cartridge from corrosion.

Obtain Flat Response in All Fields

Like Type 4198, UA-1404 includes a disc containing detailed free-field corrections for each microphone recommended for use with the kit. See the Type 4198 section above for more information.

Type 2236 Considerations

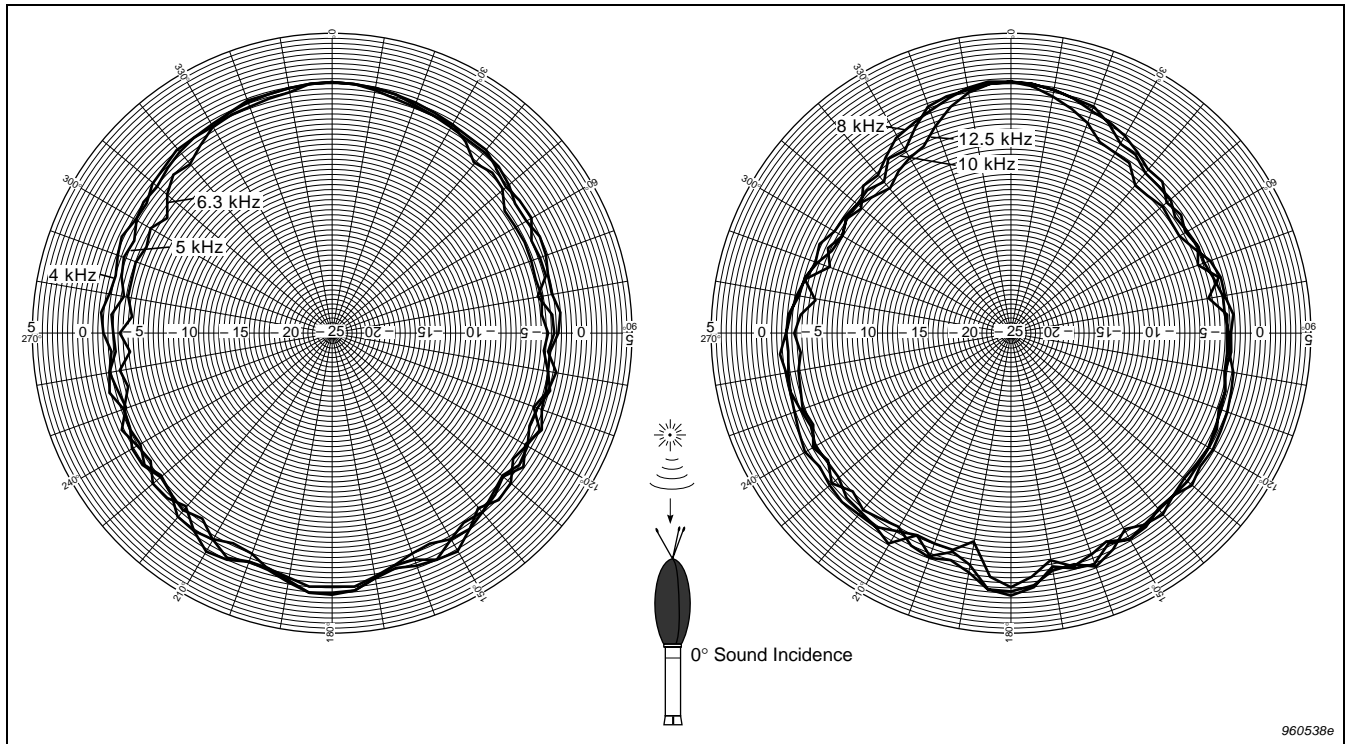

UA-1404 extends the distance between the microphone and the preamplifier. This causes a 2 dB loss in the sound signal, which may invalidate your instrument's calibration. You must therefore check the chart that came with your Type 4188 microphone. Make sure the sensitivity is between –30.5 dB and –28 dB before using UA-1404 with your instrument. If the sensitivity lies below –30.5 dB, then you must purchase a more sensitive Type 4188 microphone to use with UA-1404.

Fig. 6 Directional characteristics for both Type 4198 and UA-1404



960538e

Compliance with Standards

 	CE-mark indicates compliance with: EMC Directive and Low Voltage Directive. C-Tick mark indicates compliance with the EMC requirements of Australia and New Zealand.
Safety	EN/IEC 61010-1: Safety requirements for electrical equipment for measurement, control and laboratory use. UL 61010-1: Standard for Safety – Electrical measuring and test equipment.
EMC Immunity	EN/IEC 61000-6-1: Generic standards – Immunity for residential, commercial and light industrial environments. EN/IEC 61000-6-2: Generic standards – Immunity for industrial environments. Note: The above is guaranteed only with extension cables AO-0414, AO-0415 and AO-0416.
Temperature	IEC 60068-2-1 & IEC 60068-2-2: Environmental Testing. Cold and Dry Heat. Operating Temperature: -20 to +60°C (-4 to +140°F), (150°C (302°F) with increase in noise) Storage Temperature: -25 to +70°C (-13 to +158°F)
Humidity	IEC 60068-2-78: Damp Heat: 95% RH (non-condensing at 40°C (104°F))
Mechanical	Non-operating: IEC 60068-2-6: Vibration: 0.3 mm, 20 m/s ² , 10–500 Hz IEC 60068-2-27: Shock: 1000 m/s ² IEC 60068-2-29: Bump: 400 bumps at 400 m/s ²
Reliability	MI-HDBK 217F, GB (Part-Stress): MTBF >40000 hours (max. 2.5% errors/1000 h)

Specifications – Outdoor Microphone Unit Type 4198

COMPLIANCE WITH STANDARDS

The unit meets IEC 61672 class 1 and ANSI S1.4 Type 2. It also complies with the EMC Directive and Low Voltage Directive (see CE box, below).

MICROPHONE CARTRIDGE

Falcon Range Prepolarized Free-field 1/2" Microphone Type 4189^a

PREAMPLIFIER

Falcon Range 1/2" Microphone Preamplifier Type 2669-C^b

a. See separate product data sheet (BP 1380) or Microphone Handbook (BA5105) for complete specifications for this microphone

SENSITIVITY (250 Hz)

-26 ±2 dB re 1V/Pa, 50 mV/Pa
 (individually calibrated)

FREQUENCY RESPONSE

0° incidence free-field response
 ±1 dB 10 Hz to 8 kHz
 ±2 dB 6.3 Hz to 16 kHz
 In accordance with IEC 61672651 class 1

b. See separate product data sheet (BP 1422) for complete specifications for this preamplifier

LOWER LIMITING FREQUENCY (-3 dB)

2 Hz to 4 Hz

DIAPHRAGM RESONANCE FREQUENCY

14 kHz (90° phase shift)

EQUIVALENT AIR VOLUME (101.3 kPa)45 mm³**CALIBRATOR LOAD VOLUME (250Hz)**260 mm³**PIN CONNECTIONS**

Cable's output plug seen from outside

Pin	Signal
1	Calibration input
2	Signal ground
3	Pol. voltage
4	Signal output
5	TEDS data wire
6	Power supply negative & ground
7	Power supply negative & ground
Casing	Connected to instrument chassis

960517/2

PISTONPHONE TYPE 4228 CORRECTION

(with DP 0776): 0.00 dB

NOISE LEVEL

15.2 dB (A), 17.4 dB (Lin.)

UPPER LIMIT OF DYNAMIC RANGE

3% distortion: >146 dB SPL

MAXIMUM SOUND PRESSURE LEVEL

158 dB (Peak)

POWER SUPPLY, DUAL

±14 V to ±60 V

POWER SUPPLY, SINGLE

28 V to 120 V

OUTPUT DC OFFSET

≈ 1 V for dual supply, or ≈ 1/2 the voltage of a single supply

POLARIZATION VOLTAGE (EXTERNAL)

0 V

Environmental Specifications**INFLUENCE OF HUMIDITY**

< 0.1 dB at up to 95% RH (non-condensing) and 40°C

WIND NOISE ATTENUATION

> 15 dB (for wind speed up to 120 km/h)

TEMPERATURE COEFFICIENT (250 Hz)

- 0.001 dB/°C, typical (for the range -10° to +50° C (14 to 122° F))

PRESSURE COEFFICIENT (250 Hz)

- 0.010 dB/kPa

VIBRATION SENSITIVITY (<1000 Hz)62.5 dB equivalent SPL for 1 m/s² axial acceleration**MAGNETIC FIELD SENSITIVITY**

6 dB SPL for 80 A/m, 50 Hz field

ESTIMATE LONG-TERM STABILITY

> 1000 years/dB (dry air at 20°C (68°F))

> 40 years/dB (air at 20°C (68°F), 90% RH)

> 1 year/dB (air at 50°C (122°F), 90% RH)

RAIN

Rainproof to IP 44

DURABILITY**Measurement in large city environment before cleaning and drying:** > 4 weeks**Measurement in large city environment before microphone system overhaul:** > 4 months**Physical Characteristics****DIMENSIONS****Height:** 412 mm (16.2")**Diameter (at widest point):** 72 mm (2.8")**WEIGHT**

580 grams (1.3 lb.)

Specifications – Outdoor Microphone Kit UA-1404**Compatible Sound Meters****TYPE 2236 SOUND LEVEL METER**

The Type 4188 microphone (included with Type 2236) must have a sensitivity between -30.5 dB and -28 dB (see "Type 2236 Considerations," above). Preamplifier ZC-0027 (included with Type 2236) is compatible as shipped.

TYPE 2260 SOUND ANALYZER

Preamplifier ZC-0026 and Microphone Type 4189 (both included with the Type 2260) are compatible as shipped.

TYPE 2250 SOUND ANALYZER

Preamplifier ZC-0032 and Microphone Type 4189 (both included with the Type 2250) are compatible as shipped.

Compatible Microphones**TYPES 4188, 4189 AND 4190**

All microphones require a stainless steel replacement grid to meet the specified frequency characteristics. The grid also provides extra protection from corrosion. Two replacement grids are included with UA-1404: one for Microphone Type 4188, the other for Types 4189 and 4190.

Compatible Preamplifiers**TYPE 2669-B/L/C**

Compatible as shipped

TYPE 2671

Compatible as shipped

Standards**ALL RECOMMENDED CONFIGURATIONS**

IEC 61672 class 1 and ANSI S1.4 Type 2
(See configuration chart, Fig. 7)

Windscreen**WIND NOISE ATTENUATION**

> 15 dB (for wind speed up to 120 km/h)

MATERIAL

Windscreen: Open-pored polyurethane foam

Spikes: Stainless steel

Environmental Specifications**OPERATING TEMPERATURE RANGE**

-30 to +150°C (-22 to +302°F)

The actual range will be determined by the preamplifier used.

RAIN

Rainproof to IP 44

DURABILITY

Measurement in large city environment before cleaning and drying:
>4 weeks

Measurement in large city environment before microphone system
overhaul:>4 months

Physical Characteristics

DIMENSIONS

Height: 412 mm (16.2")

Diameter (at widest point): 72 mm (2.8")

WEIGHT

540 grams (1.3 lb.) (empty)

Ordering Information

Type 4198 Includes the following accessories:

Type 4189	Falcon Range Prepolarized Free-field 1/2" Microphone
Type 2669-C	Falcon Range 1/2" Microphone Preamplifier
UA-1404	Outdoor Microphone Kit
AO-0414-D-100	10 m (32.8 ft.) LEMO 1B to LEMO 1B Cable

Spare Parts

DS-0934	Replacement windscreen
UC-5360	Replacement Bird Spikes

Optional Accessories

ZG-0350	LEMO 1B to 7-pin Brüel & Kjær adaptor
UA-0587	Tripod

BNC TO BNC COAXIAL CABLES

For UA-1404 with Type 2671 Preamplifiers
AO-0426-D-100 10 m Single Screened (32.8 ft.)
AO-0087-D-100 10 m Double Screened (32.8 ft.)
Other cable lengths on request.

LEMO 1B TO LEMO 1B CABLES

For Type 4198 and UA-1404 with Preamplifier Type 2669-C
AO-0414-D-030 3 m (9.8 ft.)

Other cable lengths on request.

AR-0014 Flat Cable

LEMO 0B TO LEMO 1B

For UA-1404 with Preamplifiers Type 2669-B/L without the included cable.
AO-0419-D-030 3 m (9.8 ft.) (included with Preamplifier Type 2669-L)
Other cable lengths on request.

LEMO 0B TO BRÜEL & KJÆR CONNECTER

For UA-1404 with Preamplifiers Type 2669-B/L without the included cable.
AO-0428-D-030 3 m (9.8 ft.) (included with Preamplifier Type 2669-B)
Other cable lengths on request.

BRÜEL & KJÆR EXTENSION CABLES

For UA-1404 with Preamplifier Type 2669-B with the included cable (AO-0428).
AO-0027-D-030 3 m (9.8 ft.) Extension Cable
AO-0027-D-100 10 m (32.8 ft.) Extension Cable
AO-0027-M-030 30 m (98.4 ft.) Extension Cable

FOR TYPE 2250 OR 2260 SOUND ANALYZER

AO-0441-D-030 3 m Extension Cable (9.8 ft.)
AO-0441-D-100 10 m Extension Cable (32.8 ft.)

Fig. 7 Outdoor Microphone Kit UA-1404 schematic diagram including connections and cables required for use with compatible microphones and preamplifiers

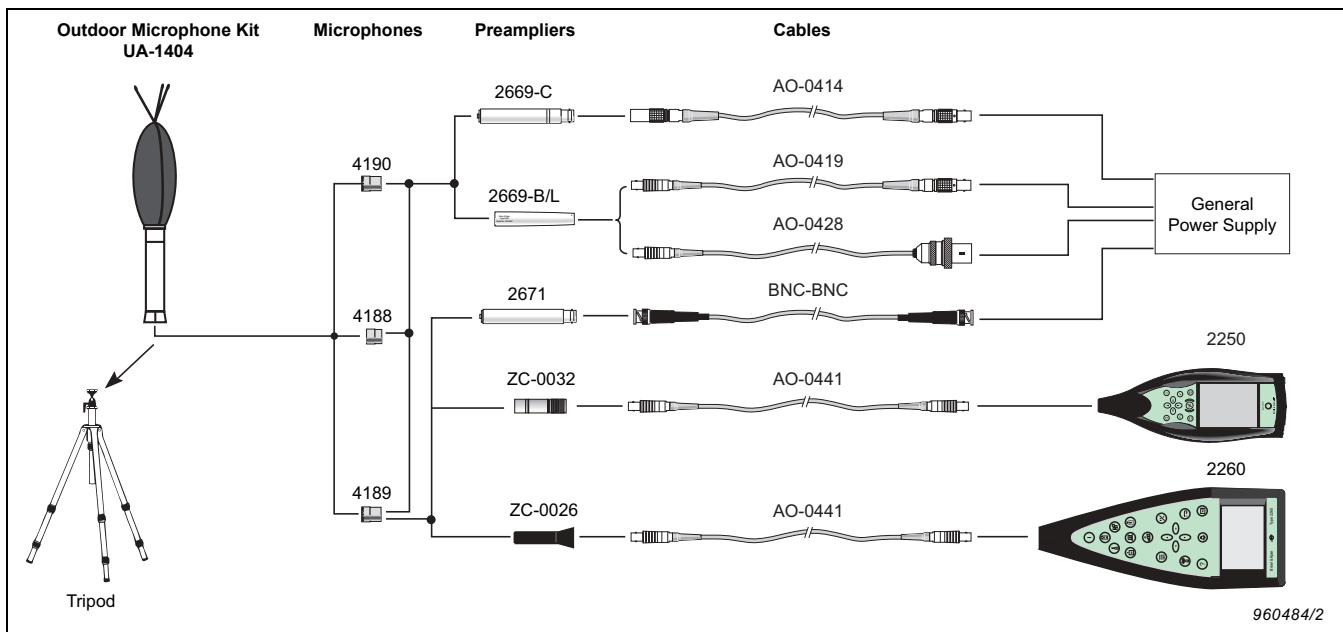

Brüel & Kjær reserves the right to change specifications and accessories without notice

HEADQUARTERS: DK-2850 Nærum · Denmark · Telephone: +45 4580 0500 · Fax: +45 4580 1405
www.bksv.com · info@bksv.com

Australia (+61) 2 9889-8888 · Austria (+43) 1 865 74 00 · Brazil (+55) 11 5188-8161
Canada (+1) 514 695-8225 · China (+86) 10 680 29906 · Czech Republic (+420) 2 6702 1100
Finland (+358) 9-521 300 · France (+33) 1 69 90 71 00 · Germany (+49) 421 17 87 0
Hong Kong (+852) 2548 7486 · Hungary (+36) 1 215 83 05 · Ireland (+353) 1 807 4083
Italy (+39) 0257 68061 · Japan (+81) 3 5715 1612 · Republic of Korea (+82) 2 3473 0605
Netherlands (+31) 318 55 9290 · Norway (+47) 66 77 11 55 · Poland (+48) 22 816 75 56
Portugal (+351) 21 41 69 040 · Singapore (+65) 6377 4512 · Slovak Republic (+421) 25 443 0701
Spain (+34) 91 659 0820 · Sweden (+46) 33 225 622 · Switzerland (+41) 44 880 7035
Taiwan (+886) 2 2502 7255 · United Kingdom (+44) 14 38 739 000 · USA (+1) 800 332 2040

Local representatives and service organisations worldwide

Brüel & Kjær 



Chapter 7

Connection to PC or Mobile Phone

7.1 Introduction

You can connect to your analyzer from a PC or mobile phone in a number of different ways using a wide range of different connection types:

- Use Utility Software for Hand-held Analyzers, BZ-5503 for full control of the analyzer – see section 7.2
- Use an Internet Browser for On-line display and control of the analyzer - see section 7.4

Three different methods are available for connecting to the Analyzer:

- USB: BZ-5503 connects to the analyzer through a USB cable
- Modem: BZ-5503 connects to the analyzer through modem (BZ-5503 uses two modems - one modem connected to the PC for dialling up, and another modem connected to the analyzer)
- Network: The analyzer is connected to a network (local or internet). BZ-5503 or an Internet Browser will then be able to connect to the analyzer through TCP/IP using the analyzer's (global) IP address

In addition to connecting to the analyzer, the analyzer itself can notify you by SMS, or E-mail, based on various conditions – see section 8.4.

Table 7.1 gives you an overview of the different connection possibilities including links to relevant chapters with more details.

Note: The on-line help for BZ-5503 contains additional information on how to connect an instrument using the different connection types.

Table 7.1 Connection overview

Connect from	Connection Type	Settings in Preferences	Available Notifications
BZ-5503	USB	Modem = <i>Disabled</i> see section 8.2.	N.A.
BZ-5503	Modem <i>analogue</i> (PSTN)	Modem = <i>Auto Answer</i> see section 8.2.	N.A.
BZ-5503	Modem GSM	Modem = <i>Auto Answer</i> . see section 8.2.	SMS ^a see section 8.4
BZ-5503 Mode	m <i>GPRS/3G</i>	Modem = <i>Auto Answer</i> . see section 8.2.	SMS ^a see section 8.4
BZ-5503 or Internet Browser <i>Mobile Phone with Internet Browser</i>	Network <i>GPRS/3G modem</i>	Modem = <i>GPRS/3G Dialup</i> Settings in Dialup Networking. Network Settings. Possibly settings in DynDNS. see section 8.2 and 8.3.	E-mail see section 8.4
BZ-5503 or Internet Browser <i>Mobile Phone with Internet Browser</i>	Network <i>Ethernet cable</i>	Modem = <i>Disabled</i> Possibly settings in DynDNS. Network Settings. see section 8.2 and 8.3.	E-mail see section 8.4
BZ-5503 or Internet Browser <i>Mobile Phone with Internet Browser</i>	Network <i>CF WLAN</i>	Modem = <i>Disabled</i> Possibly settings in DynDNS. Network Settings. Settings in Wireless Network. see section 8.2 and 8.3.	E-mail see section 8.4
BZ-5503 or Internet Browser <i>Mobile Phone with Internet Browser</i>	Network <i>DSL Modem/ Router</i>	Modem = <i>Disabled</i> Possibly settings in DynDNS. Network Settings. see section 8.2 and 8.3.	E-mail see section 8.4

a. SMS is also possible for the setting Modem = *Disabled*.

7.2 Transferring Measurement Data to Your PC

Utility Software for Hand-held Analyzers BZ-5503 is used for communication between your PC and the analyzer. Connect the analyzer to your PC using the supplied USB Cable AO-1476, using a modem connection, or through a LAN connection (see Chapter 8).

Use this software to:

- Transfer measurement data and templates from the analyzer to your PC, and vice versa
- View data
- Organise data on the analyzer

- Upgrade software on the analyzer
- Install software licenses on the analyzer

Using this software, measurements on the analyzer can be controlled from your PC and displayed on-line, using the same user interface on the PC as on the analyzer.

Data transferred to the PC are organised in Archives.

View the measurement data in the Archives or edit the project templates.

Data in the archives can be exported to:

- Noise Explorer Type 7815
- Evaluator Type 7820
- Protector Type 7825
- Predictor Type 7810
- Lima Type 7812
- Acoustic Determinator Type 7816
- Microsoft® Excel® for further post-processing and reporting

7.3 Post-processing and Reporting

The software modules are further enhanced by Brüel & Kjær's post-processing software suite, including Utility Software for Hand-held Analyzers BZ-5503 for data transfer, setup and remote display (included with your analyzer), Noise Explorer Type 7815 for viewing data, Evaluator Type 7820 for assessing environmental noise, Protector Type 7825 for assessing workplace noise.

For further information, please refer to the on-line help included with the relevant PC Software. This software is supplied on the Environmental Software DVD (BZ-5298), which is included with your the analyzer.

7.4 Internet Browser for On-line Display and Control of the Analyzer

When the analyzer is connected to a network (see Fig.7.1) you can connect to the analyzer from a PC or mobile phone using an Internet Browser supporting Java scripts.

Analyzer settings:

You access preferences by tapping on the Main Menu icon  and selecting **Preferences** from the list of options (the screen shown in Fig.8.1 will appear).

Tap on *Web Server Settings*, or select the plus icon  next to *Web Server Settings* and set the *Web Server* Parameters to *Enabled*. Define sets of Usernames and Passwords:

- one set for guest use (view only)
- one set for administrator use of the instrument (view and full control)



APPENDIX B

SCHEMATIC DRAWING OF THE MONITORING EQUIPMENTS

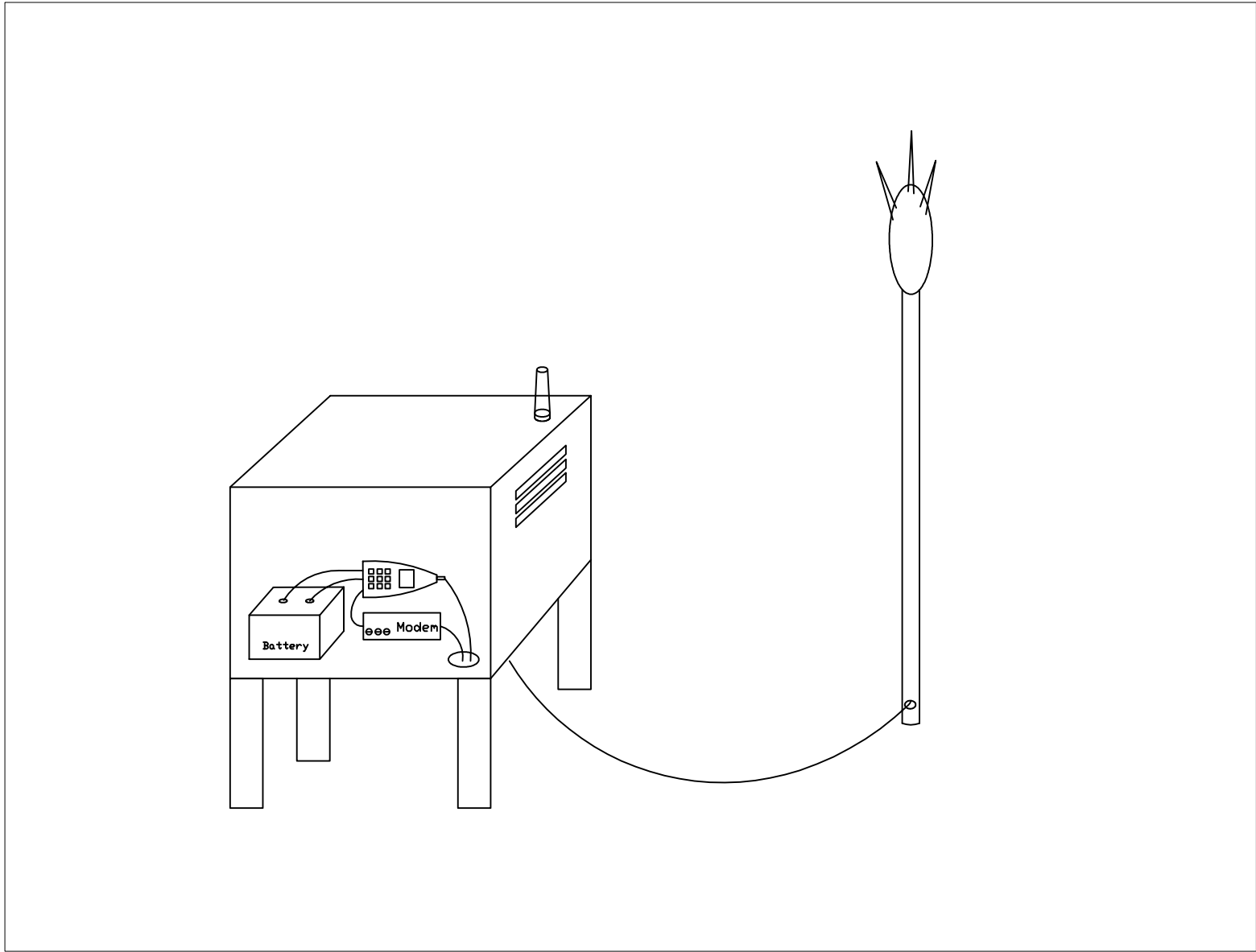

Schematic Drawing of the Monitoring Equipments

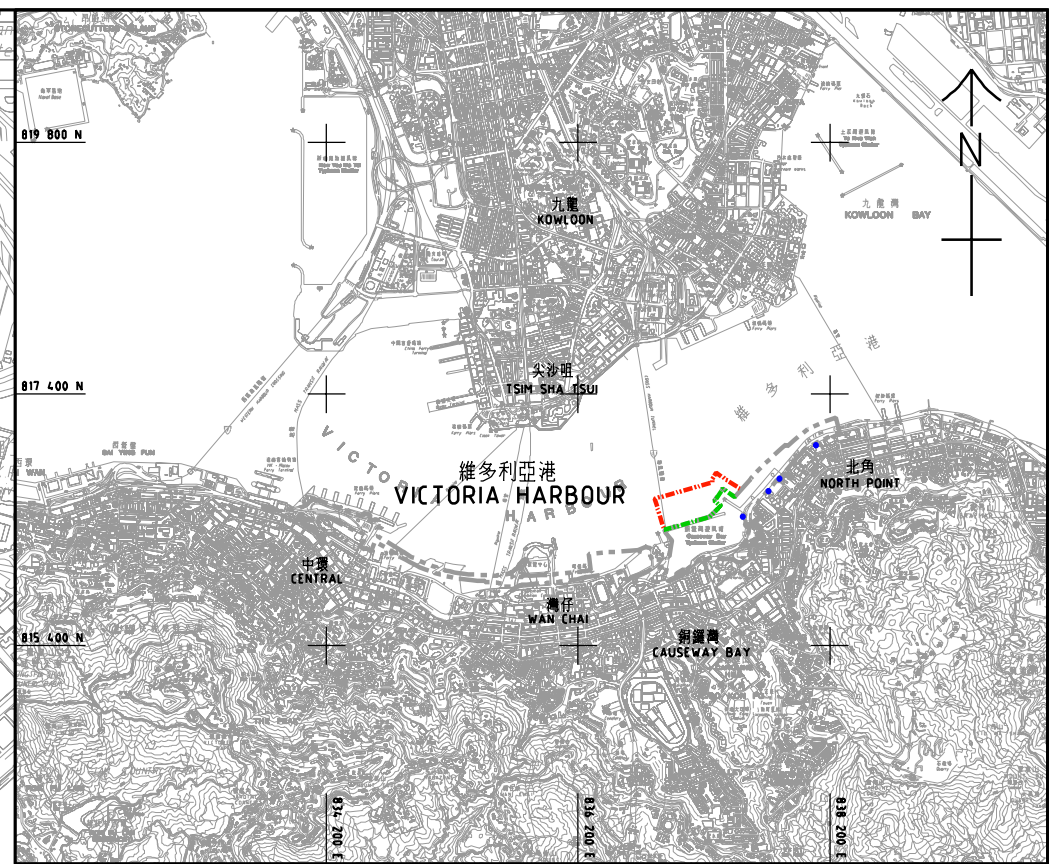
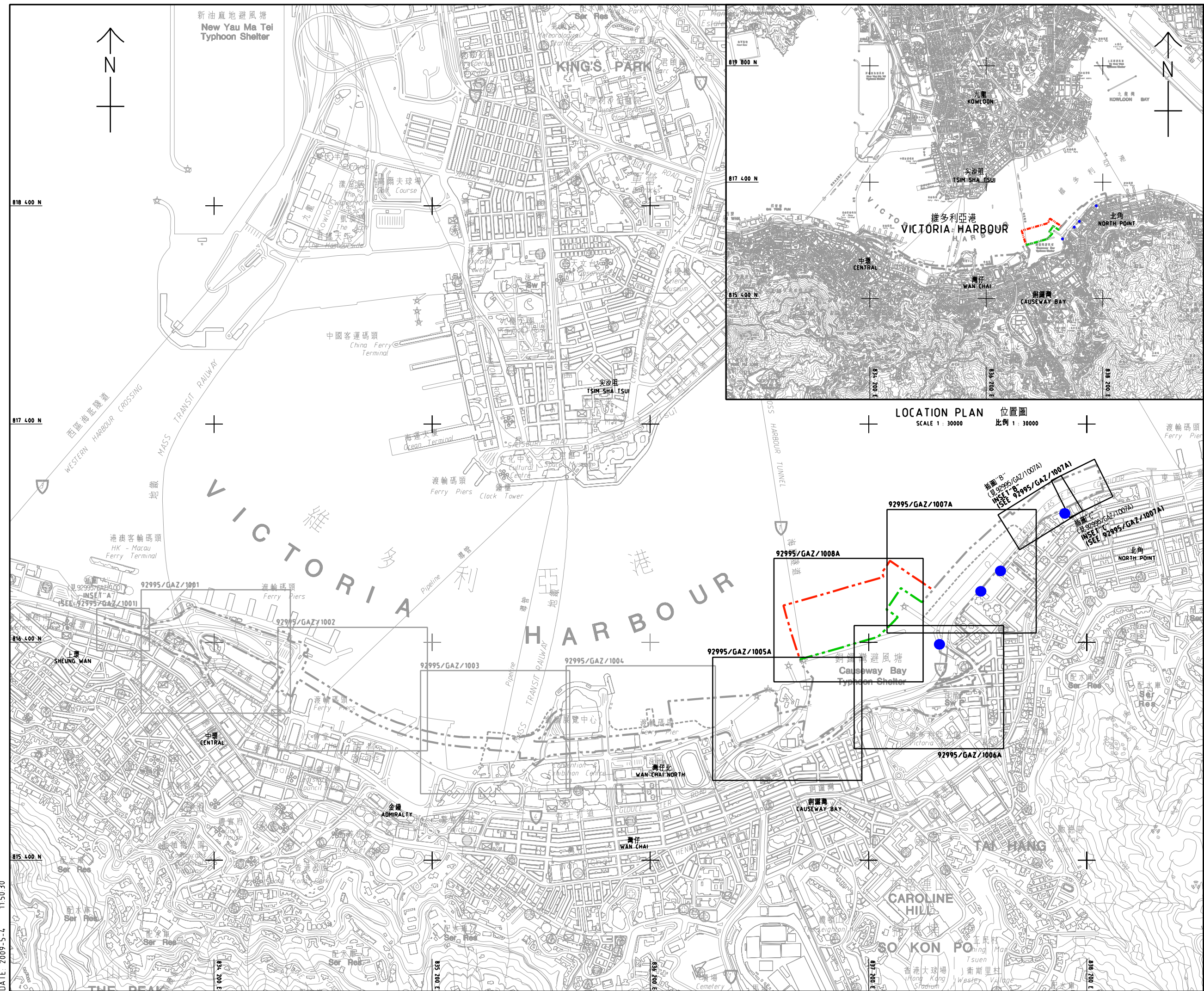

- 圖例: LEGEND:
- 原有部分 ORIGINAL
- 施工區界限 LIMIT OF WORKS AREA
 - - - 灣仔發展計劃第II期填海範圍(有關填海工程將根據前濱及海床(填海工程)條例(第127章)另行刊憲)(只供指示用途) RECLAMATION EXTENT FOR WAN CHAI DEVELOPMENT PHASE II (TO BE GAZETTED UNDER FORESHORE AND SEA-BED (RECLAMATIONS) ORDINANCE (CHAPTER 127) SEPARATELY) (FOR INDICATIVE PURPOSE ONLY)
- 修訂部分 AMENDMENT
- - - 原有建議的施工區界限將被取消 ORIGINALLY PROPOSED LIMIT OF WORKS AREA TO BE DELETED
 - 修訂後的施工區界限 AMENDED LIMIT OF WORKS AREA
 - PROPOSED REAL-TIME NOISE MONITORING STATION

LOCATION PLAN 位置圖
SCALE 1 : 30000 比例 1 : 30000

工程名稱 Project title	
工務計劃項目第6579TH號 中環灣仔繞道和東區走廊連接路 PWP ITEM NO. 6579TH CENTRAL - WAN CHAI BYPASS AND ISLAND EASTERN CORRIDOR LINK	
圖則名稱 Plan title	
根據道路(工程、使用及補償)條例 (第370章)而在憲報公布之圖則 PLAN FOR GAZETTING UNDER ROADS (WORKS, USE AND COMPENSATION) ORDINANCE (CHAPTER 370)	
圖則編號 Plan no.	比例 scale
92995/GAZ/1000A	A1 1 : 8000 A3 1 : 16000
辦事處 Office	
主要工程管理處 Major Works Project Management Office	
路政署 HIGHWAYS DEPARTMENT	

DATE: 2009-5-4 11:50:30

DATE: 2009-5-4 11:51:33

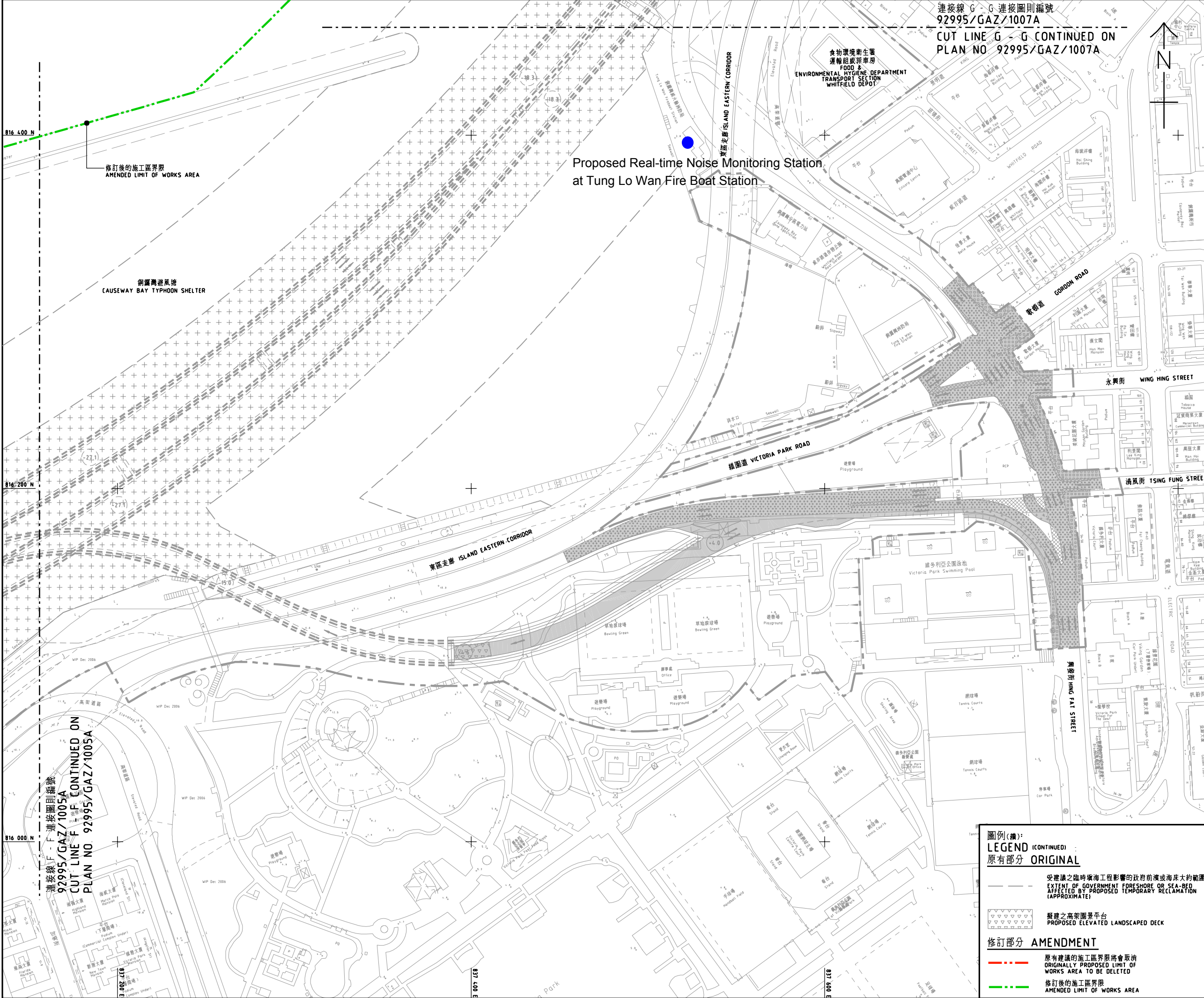

連接線 G - G 連接圖則編號
92995/GAZ/1007A
CUT LINE G - G CONTINUED ON
PLAN NO 92995/GAZ/1007A

Proposed Real-time Noise Monitoring Station
at Tung Lo Wan Fire Boat Station

註釋:
NOTES
1. 除在其他方面指定外, 所有量度均以米為單位。
ALL DIMENSIONS ARE IN METRES UNLESS OTHERWISE STATED.
2. 所有水平均為約數, 以米為單位, 並基於香港主水平基準上。
ALL LEVELS ARE APPROXIMATE VALUES AND IN METRES ABOVE HONG KONG PRINCIPAL DATUM.
3. 如有需要, 施工區界限內之現有行車道及行人路之部分路段或會分階段臨時封閉。
SECTIONS OF EXISTING CARRIAGEWAYS AND FOOTPATHS WITHIN LIMIT OF WORKS AREA MAY BE TEMPORARILY CLOSED IN PHASES AS AND WHEN REQUIRED.

圖例:
LEGEND
原有部分 ORIGINAL

	施工區界限 LIMIT OF WORKS AREA
	行車道之行車線 (每一箭頭表示一條行車線) TRAFFIC LANE FOR CARRIAGEWAY (ONE ARROW REPRESENTS ONE LANE)
	露天/於高架圍欄平台下/半開放式隔音罩下道路之建議路面水平(約數) PROPOSED ROAD LEVEL OF OPEN ROAD/ ROAD UNDER ELEVATED LANDSCAPED DECK/ ROAD UNDER NOISE SEMI-ENCLOSURE (APPROXIMATE)
	行車隧道之建議路面水平(約數) PROPOSED ROAD LEVEL INSIDE ROAD TUNNEL (APPROXIMATE)
	擬建之行人隧道(連緊急行人通道) PROPOSED ROAD TUNNEL WITH EMERGENCY PEDESTRIAN WALKWAY
	擬建之地面行車道 PROPOSED AT-GRADE CARRIAGEWAY
	擬建之行人路 PROPOSED FOOTPATH
	擬建之高架行車道 PROPOSED ELEVATED CARRIAGEWAY
	擬建之中央分隔帶/安全島 PROPOSED CENTRAL RESERVE/REFUGE ISLAND
	擬建之美化市容地帶 PROPOSED AMENITY AREA
	現有政府前濱或海床將予臨時填平, 以便興建行車隧道 EXISTING GOVERNMENT FORESHORE OR SEA-BED TO BE TEMPORARILY RECLAIMED FOR ROAD TUNNEL CONSTRUCTION
	現有地面行車道將予臨時封閉及重建 EXISTING AT-GRADE CARRIAGEWAY TO BE TEMPORARILY CLOSED AND RECONSTRUCTED
	現有地面行車道將予永久封閉及拆卸 EXISTING AT-GRADE CARRIAGEWAY TO BE PERMANENTLY CLOSED AND DEMOLISHED
	現有高架行車道將予臨時封閉及重建 EXISTING ELEVATED CARRIAGEWAY TO BE TEMPORARILY CLOSED AND RECONSTRUCTED
	現有高架行車道將予永久封閉及拆卸 EXISTING ELEVATED CARRIAGEWAY TO BE PERMANENTLY CLOSED AND DEMOLISHED
	現有行人路將予永久封閉及拆卸 EXISTING FOOTPATH TO BE PERMANENTLY CLOSED AND DEMOLISHED
	現有中央分隔帶/安全島將予重建 EXISTING CENTRAL RESERVE/REFUGE ISLAND TO BE RECONSTRUCTED
	現有中央分隔帶/安全島將予拆卸 EXISTING CENTRAL RESERVE/REFUGE ISLAND TO BE DEMOLISHED
	現有美化市容地帶將予重建 EXISTING AMENITY AREA TO BE RECONSTRUCTED
	現有美化市容地帶將予拆卸 EXISTING AMENITY AREA TO BE DEMOLISHED
	現有行人路將予臨時封閉及重建 EXISTING FOOTPATH TO BE TEMPORARILY CLOSED AND RECONSTRUCTED
	擬建之行車隧道大樓範圍 PROPOSED ROAD TUNNEL BUILDING AREA

圖例(續):
LEGEND (CONTINUED)
原有部分 ORIGINAL

	受建議之臨時填海工程影響之政府前濱或海床大約範圍 EXTENT OF GOVERNMENT FORESHORE OR SEA-BED AFFECTED BY PROPOSED TEMPORARY RECLAMATION (APPROXIMATE)
	擬建之高架圍欄平台 PROPOSED ELEVATED LANDSCAPED DECK
	修訂部分 AMENDMENT
	原有建議的施工區界限將予取消 ORIGINALLY PROPOSED LIMIT OF WORKS AREA TO BE DELETED
	修訂後的施工區界限 AMENDED LIMIT OF WORKS AREA

工程名稱 Project title
工務計劃項目第6579TH號
中環及灣仔繞道和東區走廊連接路
PWP ITEM NO. 6579TH
CENTRAL - WAN CHAI BYPASS AND
ISLAND EASTERN CORRIDOR LINK

圖則名稱 Plan title
根據道路(工程、使用及補償)條例
(第370章)而在憲報公布之圖則
PLAN FOR GAZETTING UNDER ROADS
(WORKS, USE AND COMPENSATION)
ORDINANCE (CHAPTER 370) 五張中的第三張
SHEET 3 OF 5

圖則編號 Plan no. 比例 scale
92995/GAZ/1006A A1: 1000
A3: 1: 2000

辦事處 Office
主要工程管理處
Major Works Project Management Office

路政署
HIGHWAYS
DEPARTMENT

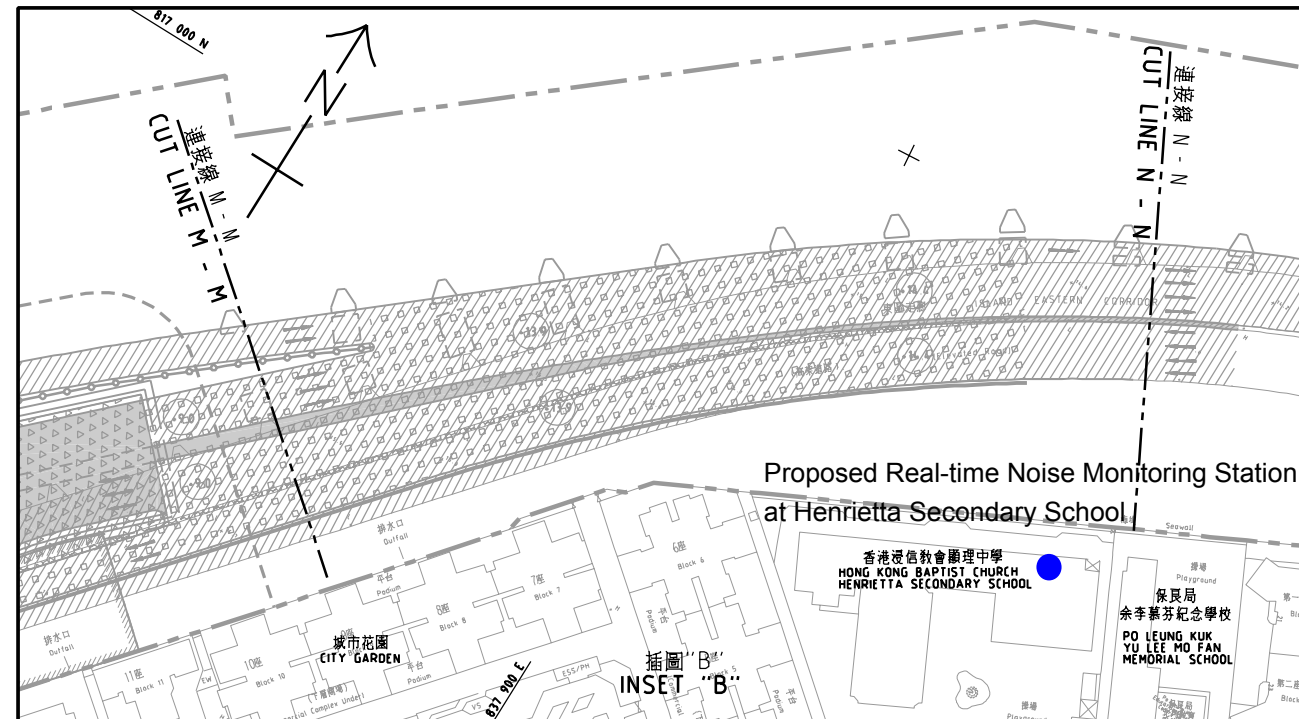

圖例(續): LEGEND (CONTINUED)
原有部分 ORIGINAL

- 灣仔發展計劃第二期填海範圍(有關填海工程將根據填海及海床(填海工程)條例(第127章)另行刊憲)(只供指示用途) RECLAMATION EXTENT FOR WAN CHAI DEVELOPMENT PHASE II (TO BE GAZETTED UNDER FORESHORE AND SEA-BED (RECLAMATIONS) ORDINANCE (CHAPTER 127) SEPARATELY) (FOR INDICATIVE PURPOSE ONLY)
- 受建議之臨時防波堤影響的政府前濱或海床大約範圍 EXTENT OF GOVERNMENT FORESHORE OR SEA-BED AFFECTED BY PROPOSED TEMPORARY BREAKWATER (APPROXIMATE)
- 受建議之臨時填海工程影響的政府前濱或海床大約範圍 EXTENT OF GOVERNMENT FORESHORE OR SEA-BED AFFECTED BY PROPOSED TEMPORARY RECLAMATION (APPROXIMATE)

圖例(續): LEGEND (CONTINUED)
原有部分 ORIGINAL

- 擬建之行人車道地下輸氣/排氣管道 PROPOSED ROAD TUNNEL BURIED FRESH/EXHAUST AIR ADITS
- 擬建之高架圍欄平台(以供噪音緩解措施) PROPOSED ELEVATED LANDSCAPED DECK (FOR NOISE MITIGATION MEASURE)
- 擬建之隔音屏障 PROPOSED NOISE BARRIER
- 擬建之半開放式隔音罩 PROPOSED NOISE SEMI-ENCLOSURE

修訂部分 AMENDMENT

- 原有建議的施工區界限將會取消 ORIGINALY PROPOSED LIMIT OF WORKS AREA TO BE DELETED
- 修訂後的施工區界限 AMENDED LIMIT OF WORKS AREA
- 原有受建議之臨時防波堤影響的政府前濱或海床大約範圍將會取消 EXTENT OF GOVERNMENT FORESHORE OR SEA-BED AFFECTED BY ORIGINALLY PROPOSED TEMPORARY BREAKWATER (APPROXIMATE) TO BE DELETED
- 原有建議之臨時填海工程影響的政府前濱或海床大約範圍將會取消 EXTENT OF GOVERNMENT FORESHORE OR SEA-BED AFFECTED BY ORIGINALLY PROPOSED TEMPORARY RECLAMATION (APPROXIMATE) TO BE DELETED

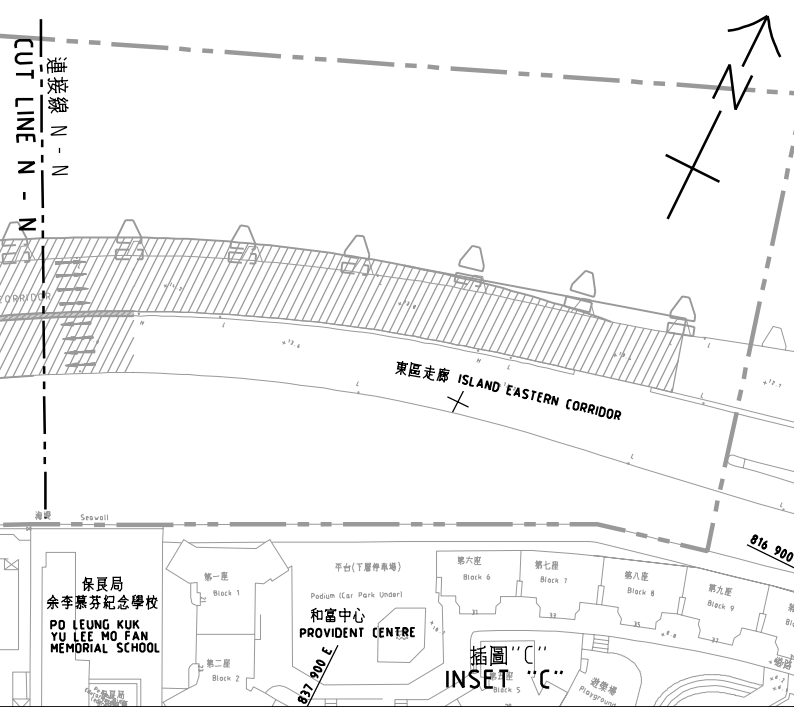
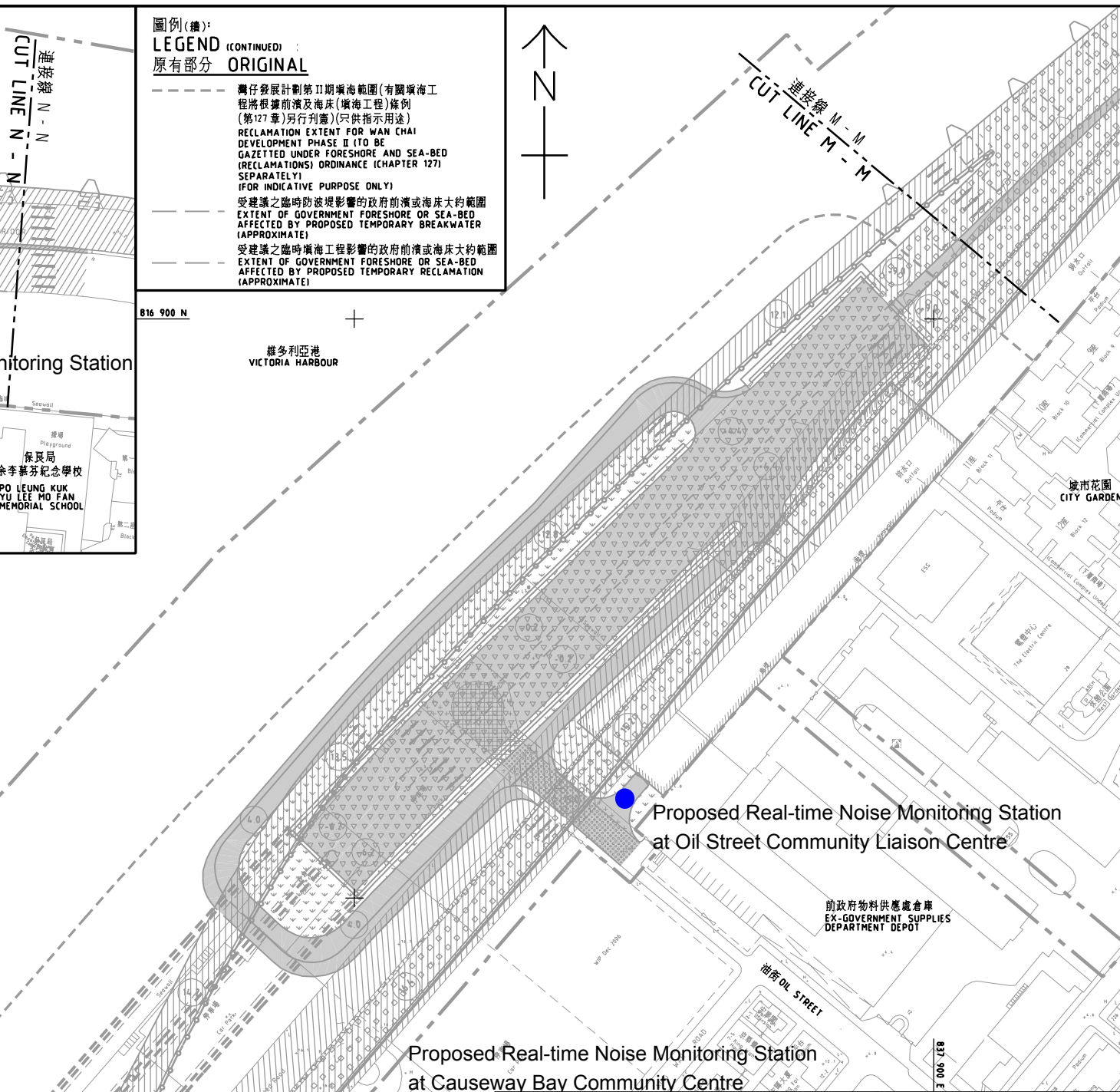
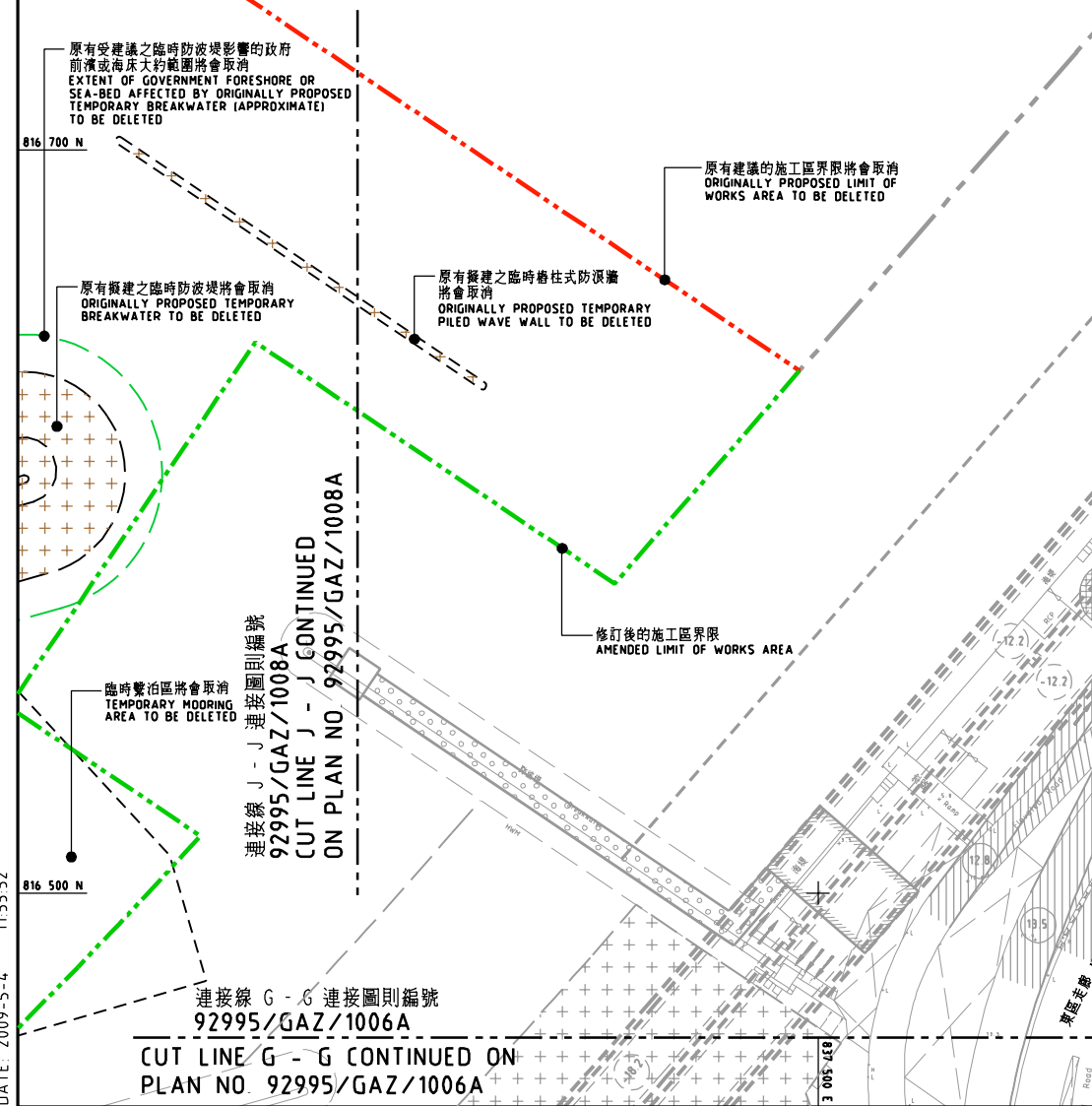

註釋: NOTES

- 除在其他方面指定外,所有量度以米為單位。 ALL DIMENSIONS ARE IN METRES UNLESS OTHERWISE STATED.
- 所有水平均為約數,以米為單位,並基於香港主水平基準上。 ALL LEVELS ARE APPROXIMATE VALUES AND IN METRES ABOVE HONG KONG PRINCIPAL DATUM.
- 如有需要,施工區界限內之現有行車道及行人路之部分路段或會分階段臨時封閉。 SECTIONS OF EXISTING CARRIAGEWAYS AND FOOTPATHS WITHIN LIMIT OF WORKS AREA MAY BE TEMPORARILY CLOSED IN PHASES AS AND WHEN REQUIRED.

圖例: LEGEND
原有部分 ORIGINAL

- 施工區界限 LIMIT OF WORKS AREA
- 行車道的行車線 (每一箭碼表示一條行車線) TRAFFIC LANE FOR CARRIAGEWAY (ONE ARROW REPRESENTS ONE LANE)
- 露天/於高架圍欄平台下/半開放式隔音罩下道路之建議路面水平(約數) PROPOSED ROAD LEVEL OF OPEN ROAD/ROAD UNDER ELEVATED LANDSCAPED DECK/ROISE SEMI-ENCLOSURE (APPROXIMATE)
- 行車隧道之建議路面水平(約數) PROPOSED ROAD LEVEL INSIDE ROAD TUNNEL (APPROXIMATE)
- 擬建之行人車道(連緊急行人通道) PROPOSED ROAD TUNNEL WITH EMERGENCY PEDESTRIAN WALKWAY
- 擬建之地面行車道 PROPOSED AT-GRADE CARRIAGEWAY
- 擬建之行人路 PROPOSED FOOTPATH
- 擬建之高架行車道 PROPOSED ELEVATED CARRIAGEWAY
- 擬建之中央分隔帶/安全島 PROPOSED CENTRAL RESERVE/REFUGE ISLAND
- 擬建之美化市容地帶 PROPOSED AMENITY AREA
- 現有政府前濱或海床將予臨時填平,以便興建行車隧道 EXISTING GOVERNMENT FORESHORE OR SEA-BED TO BE TEMPORARILY RECLAIMED FOR ROAD TUNNEL CONSTRUCTION
- 現有地面行車道將予臨時封閉及重建 EXISTING AT-GRADE CARRIAGEWAY TO BE TEMPORARILY CLOSED AND RECONSTRUCTED
- 現有地面行車道將予永久封閉及拆卸 EXISTING AT-GRADE CARRIAGEWAY TO BE PERMANENTLY CLOSED AND DEMOLISHED
- 現有高架行車道將予臨時封閉及重建 EXISTING ELEVATED CARRIAGEWAY TO BE TEMPORARILY CLOSED AND RECONSTRUCTED
- 現有高架行車道將予永久封閉及拆卸 EXISTING ELEVATED CARRIAGEWAY TO BE PERMANENTLY CLOSED AND DEMOLISHED
- 現有行人路將予永久封閉及拆卸 EXISTING FOOTPATH TO BE PERMANENTLY CLOSED AND DEMOLISHED
- 現有中央分隔帶/安全島將予重建 EXISTING CENTRAL RESERVE/REFUGE ISLAND TO BE RECONSTRUCTED
- 現有中央分隔帶/安全島將予拆卸 EXISTING CENTRAL RESERVE/REFUGE ISLAND TO BE DEMOLISHED
- 現有美化市容地帶將予重建 EXISTING AMENITY AREA TO BE RECONSTRUCTED
- 現有美化市容地帶將予拆卸 EXISTING AMENITY AREA TO BE DEMOLISHED
- 現有行人路將予臨時封閉及重建 EXISTING FOOTPATH TO BE TEMPORARILY CLOSED AND RECONSTRUCTED
- 擬建之行車隧道大體範圍 PROPOSED ROAD TUNNEL BUILDING AREA

工程名稱 Project title
 工務計劃項目第6579TH號
 中環及灣仔繞道和東區走廊連接路
 PWP ITEM NO. 6579TH
 CENTRAL - WAN CHAI BYPASS AND
 ISLAND EASTERN CORRIDOR LINK

圖則名稱 Plan title
 根據道路(工程、使用及補償)條例
 (第370章)而在憲報公布之圖則
 PLAN FOR GAZETTING UNDER ROADS
 (WORKS, USE AND COMPENSATION)
 ORDINANCE (CHAPTER 370)

圖則編號 Plan no. 92995/GAZ/1007A
 比例 scale A1: 1: 1000 A3: 1: 2000

辦事處 Office
 主要工程管理處
 Major Works Project Management Office

路政署
 HIGHWAYS
 DEPARTMENT

DATE: 2009-5-4 11:55:52

Proposed Location of Real-time Noise Monitoring Stations

Tung Lo Wan Fireboat Station



Legend

 Proposed Location of the microphone

Causeway Bay Community Centre



Hong Kong Baptist Church Henrietta Secondary School

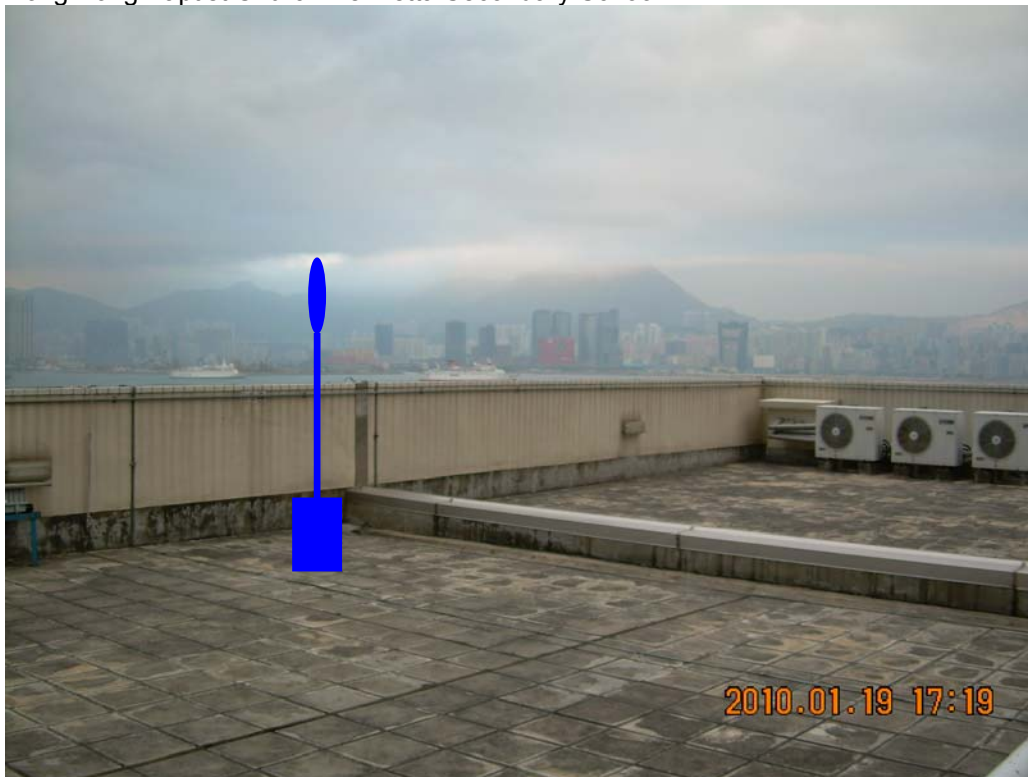

Legend

 Proposed Location of the microphone

Oil Street Community Liaison Centre



Legend



Proposed Location
of the microphone

Appendix N
Construction Programmes of
Works Contracts

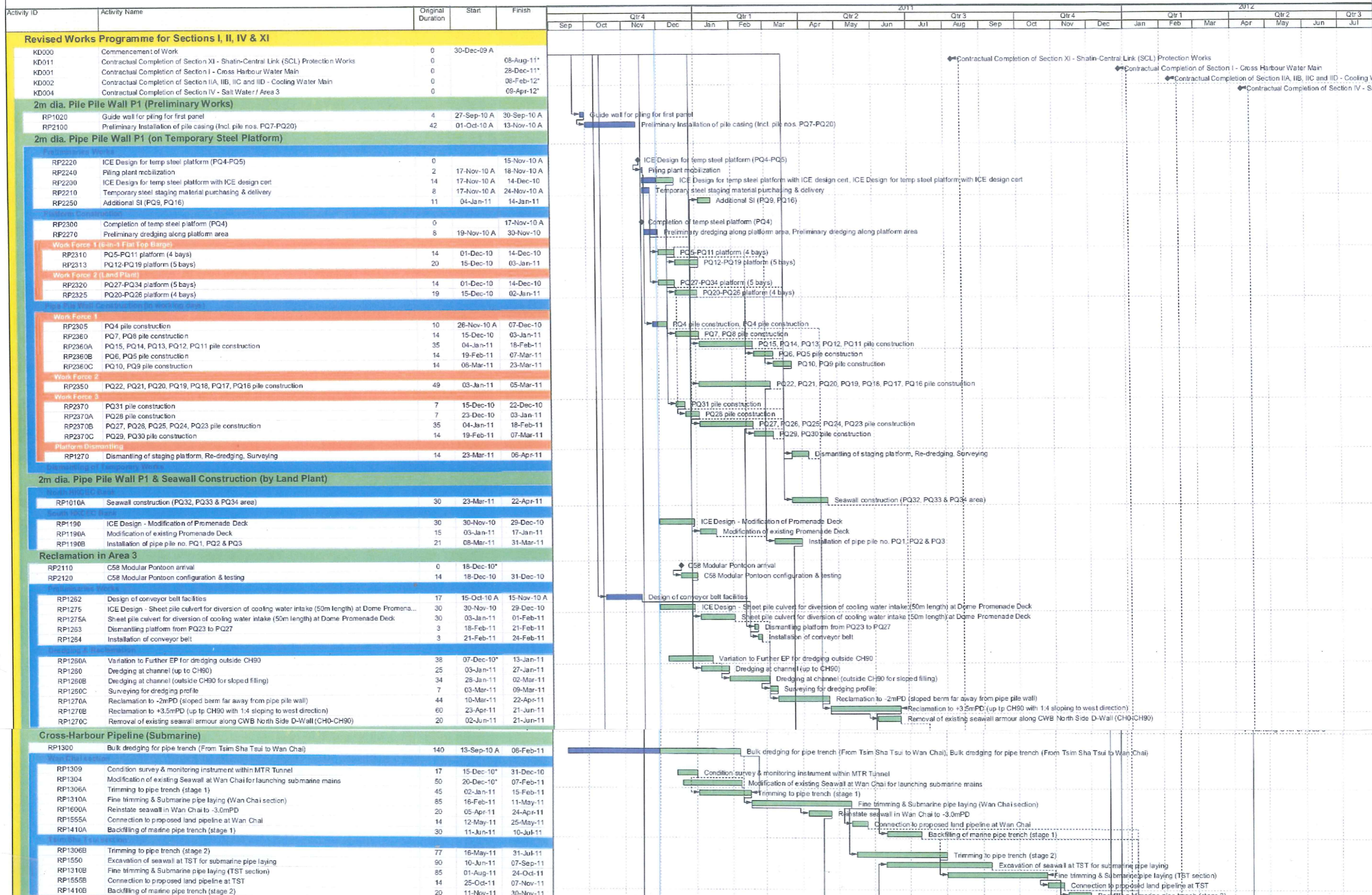

CEDD CONTRACT NO. HK/2009/01

Wan Chai Development Phase II - Central-Wan Chai Bypass at HKCEC (Contract 1)

REVISED WORKS PROGRAMME FOR SECTIONS I, II, IV & XI

Date	Revision	Checked	Approved
30-Nov-10	Rev. 4		

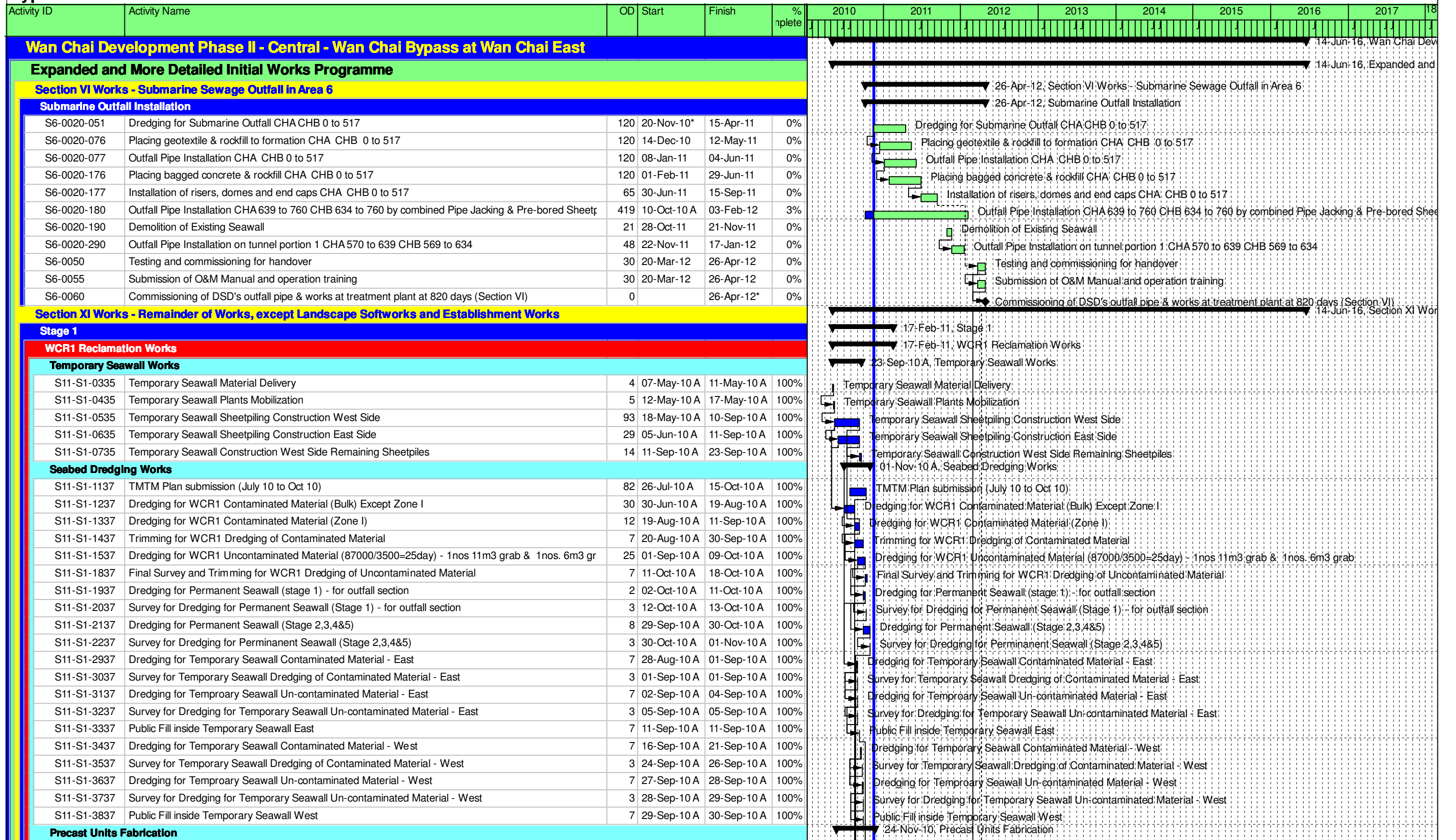

■ Remaining Level of Effort ◆ ◆ Milestone
■ Actual Level of Effort ◀ Summary
■ Actual Work
■ Remaining Work
■ Critical Remaining Work

CEDD CONTRACT NO. HK/2009/02
Wan Chai Development Phase II - Central Wan Chai Bypass at HKCEC (Contract 2)
Revised Programme dated 20 November 2010

Date	Revision	Checked	Approved
22-Nov-10		KT	KY

Page 1 of 3

Activity ID	Activity Name	OD	Start	Finish	% nplete	2010	2011	2012	2013	2014	2015	2016	2017	18
S4C-160	Precast Works of Caisson Seawall x 6 nos	101	26-May-10 A	28-Oct-10 A	100%									
S4C-360	Precast Works of Salt Water Intake Culverts (Sections in Seawall Blocks)	40	04-Oct-10 A	10-Nov-10 A	100%									
S4C-460	Precast Works of Box Culvert N1 (Sections in Seawall Blocks)	40	03-Oct-10 A	24-Nov-10	90%									
Precast Units Installation														
S11-S1-1026	TMTM Plan submission (Period Oct 10 to Jan 10)	90	16-Oct-10 A	13-Jan-11*	10%									
S11-S1-1027	Seawall Bedding - Rock Armour G400	19	24-Oct-10 A	29-Nov-10	68%									
S11-S1-1029	Seawall Bedding - Leveling Stone	14	17-Nov-10 A	15-Dec-10	20%									
S11-S1-1040	Installation of Z-section Submarine Outfall	21	16-Oct-10 A	26-Nov-10	90%									
S11-S1-1285	MDN Approval of Delivery of Precast Units	14	21-Sep-10 A	04-Oct-10 A	100%									
S11-S1-1290	1st Delivery of Precast Units	0	03-Dec-10*		0%									
S11-S1-1295	2nd Delivery of Precast Units	0	18-Dec-10		0%									
S11-S1-1330	Temporary Loading of Precast Caisson no. 1R	1	03-Dec-10	03-Dec-10	0%									
S11-S1-1332	Installation of Pumping Station P9	1	04-Dec-10	04-Dec-10	0%									
S11-S1-1333	Installation of Pumping Station P7 & P8	2	06-Dec-10	07-Dec-10	0%									
S11-S1-1400	Installation of Precast Caisson no. 1R	1	15-Dec-10	16-Dec-10	0%									
S11-S1-1435	Installation of Precast Caisson no. 2L-1	1	18-Dec-10	18-Dec-10	0%									
S11-S1-1440	Installation of Precast Caisson no. 2S x 2nos	3	20-Dec-10	22-Dec-10	0%									
S11-S1-1445	Installation of Precast Caisson no. 2L-2	1	23-Dec-10	23-Dec-10	0%									
S11-S1-1449	Permanent Seawall Block Work Type 4 & Installation of Precast Intake Unit	14	08-Dec-10	23-Dec-10	0%									
S11-S1-1549	Permanent Seawall Block Work Type 5	14	16-Dec-10	04-Jan-11	0%									
S11-S1-1735	Permanent Seawall Block Work Type 6 & Installation Precast N1 Culverts	14	29-Jan-11	17-Feb-11	0%									
S4A-0010-130	Water Tightness Test for P8	60	20-Nov-10	31-Jan-11	0%									
S4B-0010-170	Water Tightness Test for P9	60	20-Nov-10	31-Jan-11	0%									
S4C-0010-210	Water Tightness Test for P7	60	20-Nov-10	31-Jan-11	0%									
Bulk Reclamation														
S11-S1-2035	1st Stage Bulk Reclamation by hopper barge (from dredging level to +2.5mPd)	46	08-Dec-10	01-Feb-11	0%									
S11-S1-2135	2nd Stage Bulk Reclamation by Land Plant (from +2.5mPd to +4.2 mPd)	15	28-Jan-11	17-Feb-11	0%									
Stage 2														
S11-S2-0010	WCR2 seabed dredging and temporary seawall work	60	08-Mar-12	23-May-12	0%									
S11-S2-0020	WCR2 bulk reclamation work	60	23-May-12	02-Aug-12	0%									
S11-S2-0025	Receive As-built Information of Bowrington Box Culvert O	0	20-Nov-10*		0%									
S11-S2-0030	Drainage diversion of existing Bowrington Box Culvert O to basin of ex-PCWA	180	20-Nov-10	29-Jun-11	0%									
S11-S2-0040	WCR4 seabed dredging	30	27-Apr-12	02-Jun-12	0%									
S11-S2-0050	Commencement of TWRC4 temporary reclamation (with duration of 38 months)	0	04-Jun-12		0%									
S11-S2-0060	TWCR4 seabed dredging & temporary seawall work	30	04-Jun-12	09-Jul-12	0%									
S11-S2-0070	TWCR4 bulk and temporary reclamation work	20	10-Jul-12	01-Aug-12	0%									
S11-S2-0080	WCR4 bulk and temporary reclamation work	20	10-Jul-12	01-Aug-12	0%									
S11-S2-0090	Prepare temporary at-grade road access	60	02-Aug-12	11-Oct-12	0%									
S11-S2-0100	Removal of portion 1 of box culvert O above tunnel portion 3 (area not at Hung Hing Road)	180	30-Jun-11	03-Feb-12	0%									
S11-S2-0110	Construct steel bridge no.1	30	18-Sep-12	24-Oct-12	0%									
S11-S2-0120	Implement diversion of Hung Hing Road at-grade traffic	2	25-Oct-12	26-Oct-12	0%									
S11-S2-0130	Removal of portion 2 of box culvert O above tunnel portion 3 (area at Hung Hing Road)	40	27-Oct-12	12-Dec-12	0%									
S11-S2-0140	Provision of new landing step on existing seawall (for area 9A handover)	210	06-Dec-12	21-Aug-13	0%									
Stage 3														
S11-S3-0010	Reinstate box culvert O above tunnel portion 3	59	13-Jun-13	21-Aug-13	0%									
S11-S3-0020	Reinstate temporary outfall of box culvert O and associated seawall etc. at ex-PCWA	30	22-Aug-13	26-Sep-13	0%									
S11-S3-0030	Widen temporary road to area above tunnel portion 3 & box culvert "O"	30	22-Aug-13	26-Sep-13	0%									
S11-S3-0040	Implement diversion of at-grade traffic via new road above tunnel portion 3 & box culvert "O"	2	22-Aug-13	23-Aug-13	0%									
S11-S3-0050	Handover of Area 9 to adjacent contractor HY/2009/15 at 1340 days (Section IXA)	0		27-Sep-13	0%									

Activity ID	Activity Name	OD	Start	Finish	% Complete	2010	2011	2012	2013	2014	2015	2016	2017	18
S11-S3-0060	Construct temporary steel bridge no. 2 above tunnel portion 3 & box culvert "O"	40	27-Sep-13	13-Nov-13	0%									
S11-S3-0070	Diversion of existing Hung Hing Road flyover traffic via temporary road & steel bridge no. 2	2	14-Nov-13	15-Nov-13	0%									
S11-S3-0080	Removal of approach ramp of existing Hung Hing Road flyover	30	16-Nov-13	20-Dec-13	0%									
Stage 4														
S11-S4-0010	Reinstate original approach ramp of flyover and the associated road work of Hung Hing Road	75	13-Nov-14	11-Feb-15	0%									
S11-S4-0020	Diversion of Hung Hing Road flyover traffic back to original	2	12-Feb-15	13-Feb-15	0%									
S11-S4-0030	Remove temporary steel bridge no.2 and reinstate Hung Hing Road	45	03-Jan-15	27-Feb-15	0%									
S11-S4-0040	Diversion of Hung Hing Road at-grade traffic back to original	2	28-Feb-15	02-Mar-15	0%									
S11-S4-0050	Excavate and remove top portion of diaphragm wall for permanent seawall work at WCR4	40	03-Mar-15	20-Apr-15	0%									
S11-S4-0060	Remove temporary seawall & temporary reclamation at TWCR4	40	21-Apr-15	08-Jun-15	0%									
S11-S4-0070	WCR4 permanent seawall work	45	09-Jun-15	01-Aug-15	0%									
S11-S4-0080	Completion of TWCR4 reinstatement (with duration of 38 months)	0		01-Aug-15*	0%									
S11-S4-0090	Designated completion of TWCR4	0		02-Aug-15	0%									
S11-S4-0100	WCR4 backfilling behind permanent seawall	15	03-Aug-15	19-Aug-15	0%									
S11-S4-0110	WCR3 seabed dredging for permanent seawall	90	18-Mar-14	08-Jul-14	0%									
S11-S4-0120	WCR3 backfilling and permanent seawall work	90	09-Jul-14	24-Oct-14	0%									
S11-S4-0130	WCR3 bulk reclamation work	60	25-Oct-14	06-Jan-15	0%									
S11-S4-0140	Carry out temporary drilling & grouting in sealing up the existing 2M pipe pile wall near Area 10	14	07-May-15	22-May-15	0%									
S11-S4-0240	Remaining Work on Land in Area 11	120	18-Jan-16	14-Jun-16	0%									

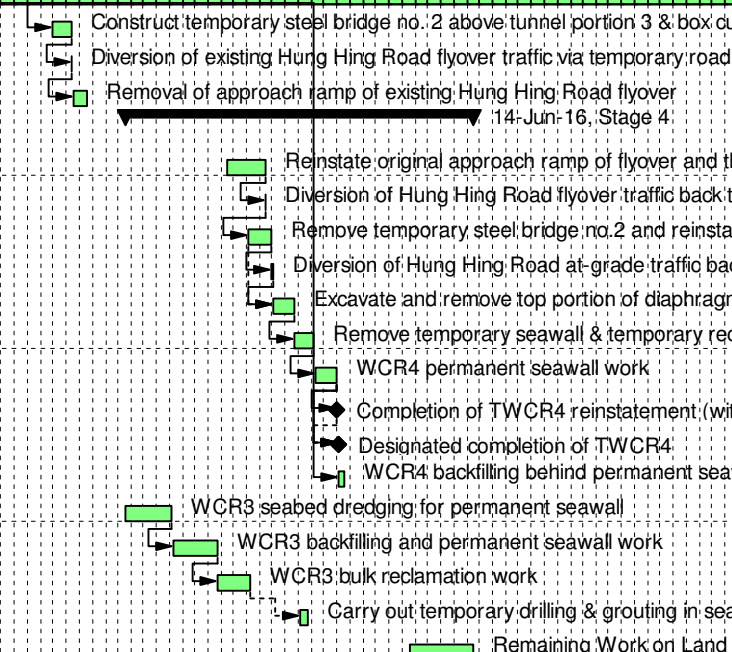

Activity ID	Activity Name	Original Duration	Remaining Duration	Start	Finish	Total Float	2011													
							Jan	Feb	Mar	Apr	May	Jun	Jul	Aug						
							14	15	16	17	18	19	20	21						
DWP ver7 08Feb11 Detailed Works Programme ver.7 updated 08Feb2011																				
DWP ver7 08Feb11.PR PRELIMINARIES																				
DWP ver7 08Feb11.PR.030 COMPLETION SECTION OF WORKS																				
K11100	Completion Section II of Works	0	0		06-Apr-11*	0														
K11200	Completion Section III of Works	0	0		13-Aug-11*	0														
DWP ver7 08Feb11.PR.060 PRE-CAST SEAWALL BLOCK																				
DWP ver7 08Feb11.PR.060.08 7th Barge of Seawall Block B5, Type 5																				
A20820	Transport seawall block B5 to site	2	2	27-Feb-11*	28-Feb-11	29														
DWP ver7 08Feb11.PR.060.09 8th Barge of Seawall Block B6&B7, Type 6 & 7																				
A20912	Casting Seawall Block B6 & B7 260nrs	60	60	14-Feb-11*	14-Apr-11	0														
A20914	Curing Seawall Block B6 & B7	60	60	26-Feb-11	26-Apr-11	0														
A20916	Transport seawall block B6 & B7 to site	50	50	10-Mar-11	28-Apr-11	0														
DWP ver7 08Feb11.PR.060.10 9th Barge of Seawall Block B8, Type 8																				
A20700	Casting Seawall Block B8 25nrs	15	15	15-Apr-11*	29-Apr-11	33														
A20710	Curing Seawall Block B8	7	7	30-Apr-11	06-May-11	33														
A20720	Transport seawall block B8 to site	2	2	27-May-11	28-May-11	13														
DWP ver7 08Feb11.R Overall Construction																				
C0010	DREDGING	185	21	16-Mar-10 A	28-Feb-11	9														
C0020	ROCKFILL GRADE 400	197	12	06-May-10	19-Feb-11	0														
C0030	LEVELING STONE & TOE BLOCKS	296	109	10-May-10	27-May-11	13														
C0040	INSTALL SEAWALL BLOCKS	307	124	15-May-10	11-Jun-11	13														
C0050	INSTALL CAISSON SEAWALLS	189	22	06-Jul-10 A	01-Mar-11	0														
C0060	ROCKFILL INSIDE CAISSON SEAWALLS	193	54	10-Jul-10 A	02-Apr-11	27														
C0080	ROCKFILL TYPE A, GEOTEXTILE TYPE A & FILTER	205	129	30-Jul-10 A	16-Jun-11	13														
C0090	RECLAMATION UPTO FINISH LEVEL	263	171	14-Aug-10 A	28-Jul-11	0														
DWP ver7 08Feb11.S2 SECTION 2 OF WORKS (470 DAYS)																				
DWP ver7 08Feb11.S2.03 SEAWALLS AND RECLAMATION WORKS																				
DWP ver7 08Feb11.S2.03.020 PORTION NPR2																				
DWP ver7 08Feb11.S2.03.020.030 SEAWALL CONSTRUCTION																				
DWP ver7 08Feb11.S2.03.020.030.01 Seawall Block Installation B3																				
43310	Install bermstone, 0.5T armour and filter layer B3	4	4	08-Feb-11	11-Feb-11	9														
DWP ver7 08Feb11.S2.03.020.030.02 Package 1 Bargeload 3 C6																				
42500	Install bermstone, 0.5T armour and filter layer C6	4	4	12-Feb-11	16-Feb-11	9														
42540	Insitu concrete on top of removal slotted panel C6	4	4	04-Mar-11	08-Mar-11	0														
DWP ver7 08Feb11.S2.03.020.030.03 Seawall Block Installation B10																				
42840	Install bermstone, 0.5T armour and filter layer B10	4	4	17-Feb-11	21-Feb-11	9														
42845	Installation and insitu concrete coping B10	12	6	11-Jan-11 A	14-Feb-11	1														
DWP ver7 08Feb11.S2.03.020.030.04 Package 2 Bargeload 1 C7 & C8																				
42600	Install bermstone, 0.5T armour and filter layer C7 & C8	4	4	22-Feb-11	25-Feb-11	9														
42640	Insitu concrete on top of removal slotted panel C7 & C8	4	4	09-Mar-11	12-Mar-11	0														
DWP ver7 08Feb11.S2.03.020.030.05 Package 1 Bargeload 4 C9 & C10																				
42550	Install bermstone, 0.5T armour and filter layer C9 & C10	4	4	26-Feb-11	02-Mar-11	9														
42590	Insitu concrete on top of removal slotted panel C9 & C10	4	4	14-Mar-11	17-Mar-11	0														
DWP ver7 08Feb11.S2.03.020.030.06 Seawall Block Installation B4																				
17330	Precast concrete coping B4	12	1	18-Jan-11 A	08-Feb-11	6														
42850	Rockfill type A, geotextile type A & filter layer B4	4	4	08-Feb-11	11-Feb-11	3														
42870	Install bermstone, 0.5T armour and filter layer B4	4	4	03-Mar-11	07-Mar-11	9														

▶ Level Effort
 ■ Remaining Work
 ◆ Milestone
■ Actual Work
 ■ Critical Remaining Work

Activity ID	Activity Name	Original Duration	Remaining Duration	Start	Finish	Total Float	2011											
							Jan	Feb	Mar	Apr	May	Jun	Jul	Aug				
							14	15	16	17	18	19	20	21				
42880	Installation and insitu concrete coping B4	12	12	15-Feb-11	28-Feb-11	1												
DWP ver7 08Feb11.S2.03.020.030.07 Package 2 Bargeload 2 C11 & C12																		
42650	Install bermstone, 0.5T armour and filter layer C11 & C12	4	4	08-Mar-11	11-Mar-11	9												
42660	Cat ladder, Handrail and manhole cover C11 & C12	7	4	01-Feb-11 A	11-Feb-11	23												
42690	Insitu concrete on top of removal slotted panel C11 & C12	4	4	18-Mar-11	22-Mar-11	0												
DWP ver7 08Feb11.S2.03.020.030.08 Package 2 Bargeload 3 C13 & C14																		
42700	Install bermstone, 0.5T armour and filter layer C13 & C14	4	4	12-Mar-11	16-Mar-11	9												
42710	Cat ladder, Handrail and manhole cover C13 & C14	7	7	12-Feb-11	19-Feb-11	23												
42740	Insitu concrete on top of removal slotted panel C13 & C14	4	4	23-Mar-11	26-Mar-11	0												
DWP ver7 08Feb11.S2.03.020.030.09 Package 2 Bargeload 4 C15 & C16																		
42750	Install bermstone, 0.5T armour and filter layer C15 & C16	4	4	17-Mar-11	21-Mar-11	9												
42760	Cat ladder, Handrail and manhole cover C15 & C16	7	7	21-Feb-11	28-Feb-11	23												
42790	Insitu concrete on top of removal slotted panel C15 & C16	4	4	28-Mar-11	31-Mar-11	0												
DWP ver7 08Feb11.S2.03.020.030.10 Package 2 Bargeload 5 C17 & C18																		
42780	Rockfill type A, geotextile type A & filter layer C17 & C18	4	4	30-Jan-11 A	11-Feb-11	15												
42800	Install bermstone, 0.5T armour and filter layer C17 & C18	4	4	22-Mar-11	25-Mar-11	9												
42810	Cat ladder, Handrail and manhole cover C17 & C18	7	7	01-Mar-11	08-Mar-11	24												
42830	Insitu concrete on top of removal slotted panel C17 & C18	4	4	01-Apr-11	06-Apr-11	0												
DWP ver7 08Feb11.S2.03.020.040 RECLAMATION																		
17600	Reclamation upto finish level (57,323m3) at NPR2	36	21	17-Dec-10 A	03-Mar-11	0												
DWP ver7 08Feb11.S2.04 DRAINAGE WORKS																		
DWP ver7 08Feb11.S2.04.020 PORTION NPR2																		
DWP ver7 08Feb11.S2.04.020.1 Open Channel T																		
18300	Construct open channel T	95	35	20-Nov-10 A	19-Mar-11	14												
18368	Blockwork east & west walls at sea side of open channel T	4	2	27-Jan-11 A	09-Feb-11	14												
18370	Rockfill type A behind west wall at sea side of open channel T	4	4	10-Feb-11	14-Feb-11	14												
18380	Blockwork west wall at land side of open channel T	4	4	15-Feb-11	18-Feb-11	14												
18390	Rockfill type A behind west wall at land side of open channel T	4	4	19-Feb-11	23-Feb-11	14												
18391	Blockwork east wall at land side of open channel T	4	4	24-Feb-11	28-Feb-11	14												
18392	construct dia 1500 pipe	5	5	01-Mar-11	05-Mar-11	14												
18395	Geotextile Type A, Filter and Imported fill on top of rockfill typeA at eas	12	12	07-Mar-11	19-Mar-11	14												
DWP ver7 08Feb11.S2.04.020.2 Land Drainage																		
18410	Mobilization of Plant	1	1	21-Feb-11*	21-Feb-11	0												
18420	Sheetpiling, Excavation & Shoring	24	24	22-Feb-11	21-Mar-11	0												
DWP ver7 08Feb11.S2.04.020.2.1 Open Channel T to MH1-T 1500mm																		
18430	Dia1500mm pipe near MH1 60m	6	6	02-Mar-11	08-Mar-11	0												
18440	Manhole MH1-T	13	13	25-Feb-11	11-Mar-11	6												
18450	Dia1500mm pipe near open channel T 30m	3	3	29-Mar-11	31-Mar-11	1												
DWP ver7 08Feb11.S2.04.020.2.2 MH1-T to MH2-T 1500mm																		
18460	Dia1500mm pipe 40m	4	4	10-Mar-11	14-Mar-11	0												
18470	Manhole MH2-T	12	12	10-Mar-11	23-Mar-11	0												
DWP ver7 08Feb11.S2.04.020.2.3 MH2-T to MH3-T 1200mm																		
18480	Dia1200mm pipe 55m	6	6	15-Mar-11	21-Mar-11	1												
18490	Manhole MH3-T	12	12	15-Mar-11	28-Mar-11	1												
DWP ver7 08Feb11.S2.04.020.2.4 Connect to existing drainage and reinstatement																		
18510	MH1-T Dia900mm pipe to existing seawall 15m	5	5	12-Mar-11	17-Mar-11	6												
18520	MH2-T Dia750mm pipe to existing seawall 17m	5	5	24-Mar-11	29-Mar-11	0												
18530	MH3-T Dia750mm pipe to existing seawall 18m	4	4	30-Mar-11	02-Apr-11	0												

▶ Level Effort
 Remaining Work
 ◆ Milestone
 Actual Work
 Critical Remaining Work

Activity ID	Activity Name	Original Duration	Remaining Duration	Start	Finish	Total Float	2011											
							Jan	Feb	Mar	Apr	May	Jun	Jul	Aug				
							14	15	16	17	18	19	20	21				
18540	Reinstatement	10	10	25-Mar-11	06-Apr-11	0												
DWP ver7 08Feb11.S2.04.020.2.5 300 & 450 Half round																		
18550	300 & 450 half round	14	14	21-Mar-11	06-Apr-11	0												
43330	Construct 300 drainage pipe	14	14	21-Mar-11	06-Apr-11	0												
DWP ver7 08Feb11.S2.06 LANDING STEPS																		
DWP ver7 08Feb11.S2.06.020 PORTION NPR2																		
18110	Landing Steps Construction	24	24	15-Feb-11	14-Mar-11	1												
DWP ver7 08Feb11.S2.07 FENDERS AND RUBBER STEPS																		
DWP ver7 08Feb11.S2.07.020 PORTION NPR2																		
18120	Fenders and Rubber Step Installation	12	12	22-Mar-11	04-Apr-11	1												
DWP ver7 08Feb11.S3 SECTION 3 OF WORKS (600 DAYS)																		
DWP ver7 08Feb11.S3.03 SEAWALLS AND RECLAMATION WORKS																		
DWP ver7 08Feb11.S3.03.030 PORTION NPR3																		
DWP ver7 08Feb11.S3.03.030.020 DREDGING																		
11440	Submission & approval of the plant for dredging under IEC	28	1	14-Sep-10 A	08-Feb-11	4												
11500	Dredging in Portion NPR3 along seawall rock mound (under IEC)	24	1	01-Dec-10 A	08-Feb-11	4												
11510	Dredging Checking along seawall rock mound under IEC	5	6	21-Jan-11 A	14-Feb-11	0												
11520	Dredging in Portion NPR3 other than seawall rock mound (under IEC)	17	17	08-Feb-11*	26-Feb-11	8												
11530	Dredging Checking other than seawall rock mound under IEC	18	18	08-Feb-11	28-Feb-11	8												
DWP ver7 08Feb11.S3.03.030.030 SEAWALL CONSTRUCTION																		
12781	Seawall foundation rockfill grade 400 CH618-CH648 at C27, C28, C29	5	5	15-Feb-11	19-Feb-11	0												
12791	Seawall foundation additional rockfill grade 400 at C30	3	3	02-Mar-11	04-Mar-11	0												
DWP ver7 08Feb11.S3.03.030.030.1 Package 3 Bargeload 1 C19 & C20																		
42900	Rockfill type A, geotextile type A & filter layer C19 & C20	4	4	12-Feb-11	16-Feb-11	21												
42920	Install bermstone, 0.5T armour and filter layer C19 & C20	6	6	30-May-11	04-Jun-11	5												
42930	Cat ladder, Handrail and manhole cover C19 & C20	12	12	30-May-11	13-Jun-11	16												
42960	In situ concrete on top of removal slotted panel C19 & C20	6	6	14-Jun-11	20-Jun-11	28												
DWP ver7 08Feb11.S3.03.030.030.2 Package 3 Bargeload 2 C21 & C22																		
42192	Install removal slotted panel C21 & C22	2	2	08-Feb-11	09-Feb-11	12												
42940	Rockfill type A inside caisson seawall C21 & C22	2	2	10-Feb-11	11-Feb-11	12												
42950	Rockfill type A, geotextile type A & filter layer C21 & C22	4	4	17-Feb-11	21-Feb-11	23												
42970	Install bermstone, 0.5T armour and filter layer C21 & C22	6	6	07-Jun-11	13-Jun-11	5												
42980	Cat ladder, Handrail and manhole cover C21 & C22	12	12	14-Jun-11	27-Jun-11	16												
43010	In situ concrete on top of removal slotted panel C21 & C22	6	6	28-Jun-11	05-Jul-11	22												
DWP ver7 08Feb11.S3.03.030.030.3 Package 3 Bargeload 3 C23 & C24																		
43040	Rockfill inside caisson seawall C23 & C24	2	2	12-Feb-11	14-Feb-11	47												
43050	Rockfill type A, geotextile type A & filter layer C23 & C24	4	4	22-Feb-11	25-Feb-11	41												
43070	Install bermstone, 0.5T armour and filter layer C23 & C24	6	6	14-Jun-11	20-Jun-11	5												
43080	Cat ladder, Handrail and manhole cover C23 & C24	12	12	28-Jun-11	12-Jul-11	16												
43110	In situ concrete on top of removal slotted panel C23 & C24	6	6	13-Jul-11	19-Jul-11	16												
DWP ver7 08Feb11.S3.03.030.030.4 Seawall Block Installation B5																		
14053	Leveling Stone & Toe Block B5	6	6	23-Feb-11	28-Feb-11	29												
14055	Install Seawall Blocks B5	14	14	01-Mar-11	14-Mar-11	29												
14065	Precast concrete coping B5	12	12	15-Mar-11	28-Mar-11	24												
43140	Rockfill type A, geotextile type A & filter layer B5	4	4	15-Mar-11	18-Mar-11	27												
43160	Install bermstone, 0.5T armour and filter layer B5	6	6	21-Jun-11	27-Jun-11	5												
43170	Installation and in situ concrete coping B5	12	12	29-Mar-11	12-Apr-11	47												
DWP ver7 08Feb11.S3.03.030.030.5 Package 3 Bargeload 4 C25 & C26																		

▶ Level Effort ■ Remaining Work ◆ Milestone
■ Actual Work ■ Critical Remaining Work

Activity ID	Activity Name	Original Duration	Remaining Duration	Start	Finish	Total Float	2011												
							Jan	Feb	Mar	Apr	May	Jun	Jul	Aug					
							14	15	16	17	18	19	20	21					
42282	Install removal slotted panel C25 & C26	2	2	08-Feb-11	09-Feb-11	57													
43090	Rockfill inside caisson seawall C25 & C26	2	2	10-Feb-11	11-Feb-11	57													
43100	Rockfill type A, geotextile type A & filter layer C25 & C26	4	4	19-Mar-11	23-Mar-11	27													
43120	Install bermstone, 0.5T armour and filter layer C25 & C26	6	6	28-Jun-11	05-Jul-11	5													
43130	Cat ladder, Handrail and manhole cover C25 & C26	12	12	13-Jul-11	26-Jul-11	16													
43150	Insitu concrete on top of removal slotted panel C25 & C26	6	6	20-Jul-11	26-Jul-11	16													
DWP ver7 08Feb11.S3.03.030.030.6 Package 3 Bargeload 5 C27, C28, C29 & C30																			
42190	Leveling Stone & Toe Block C28, C29	6	6	20-Feb-11	25-Feb-11	0													
42210	Install caisson seawalls C28, C29	4	4	26-Feb-11	01-Mar-11	0													
42213	Levelling stone & toe block at C30	3	3	05-Mar-11	08-Mar-11	0													
42214	Install caisson seawall C30	1	1	09-Mar-11	09-Mar-11	0													
42215	Levelling stone & toe block at C27	3	3	28-Mar-11	30-Mar-11	0													
42216	Install caisson seawall C27	1	1	31-Mar-11	31-Mar-11	0													
42990	Rockfill type A inside caisson seawall C27, C28, C29 & C30	2	2	01-Apr-11	02-Apr-11	19													
42992	Precast concrete coping C27,C28,C29 & C30	24	24	04-Apr-11	06-May-11	19													
43000	Rockfill type A, geotextile type A & filter layer C27, C28, C29 & C30	4	4	07-May-11	12-May-11	19													
43020	Install bermstone, 0.5T armour and filter layer C27, C28, C29 & C30	6	6	13-Jul-11	19-Jul-11	5													
DWP ver7 08Feb11.S3.03.030.030.7 Seawall Block Installation B6 & B7																			
14058	Leveling Stone & Toe Block B6 & B7	12	12	21-Feb-11*	04-Mar-11	9													
14060	Install Seawall Blocks B6 & B7 upto -3.95mPD	14	14	11-Mar-11	26-Mar-11	0													
14062	Install Seawall Blocks B6 & B7 upto +1.45mPD	28	28	01-May-11*	28-May-11	1													
43180	Rockfill type A, geotextile type A & filter layer B6 & B7	6	6	28-Jun-11	05-Jul-11	0													
43182	Precast concrete coping B6 & B7	12	12	30-May-11	13-Jun-11	0													
43190	Installation and insitu concrete coping B6 & B7	12	12	14-Jun-11	27-Jun-11	0													
43200	Install bermstone, 0.5T armour and filter layer B6 & B7	6	6	20-Jul-11	26-Jul-11	5													
DWP ver7 08Feb11.S3.03.030.030.8 Seawall Block Installation B8																			
14068	Leveling Stone & Toe Block B8	10	10	17-May-11	27-May-11	10													
14070	Install Seawall Blocks B8	14	14	29-May-11	11-Jun-11	13													
43220	Rockfill type A, geotextile type A & filter layer B8	4	4	13-Jun-11	16-Jun-11	11													
43240	Install bermstone, 0.5T armour and filter layer B8	6	6	06-Jul-11	12-Jul-11	5													
43242	Construction of outstanding seawall B8	6	6	05-Jul-11	11-Jul-11	0													
43244	Precast concrete coping B8	12	12	12-Jul-11	25-Jul-11	0													
43250	Installation and insitu concrete coping B8	12	12	26-Jul-11	08-Aug-11	0													
DWP ver7 08Feb11.S3.03.030.040 RECLAMATION																			
DWP ver7 08Feb11.S3.03.030.040.1 Inclinator																			
17800	Set up plant for inclinometers installation	2	2	10-Mar-11	11-Mar-11	0													
17860	Install Inclinator 3nrs west side	12	12	12-Mar-11	25-Mar-11	0													
17870	Install Inclinator 3nrs east side	12	12	01-Apr-11	15-Apr-11	0													
DWP ver7 08Feb11.S3.03.030.040.2 Steel Protection Ties																			
17880	Set up plant for steel protection ties	3	3	23-Mar-11	25-Mar-11	0													
17890	Steel protection ties construction west side	3	3	26-Mar-11	29-Mar-11	0													
17900	Steel protection ties construction east side	3	3	16-Apr-11	19-Apr-11	0													
DWP ver7 08Feb11.S3.03.030.040.3 Reclamation																			
18015	Reclamation upto finish level (105,249m3) NPR3	96	96	14-Mar-11	12-Jul-11	0													
18017	Land Compaction upto finish level NPR3	60	60	18-May-11	28-Jul-11	0													
DWP ver7 08Feb11.S3.04 DRAINAGE WORKS																			
DWP ver7 08Feb11.S3.04.030 PORTION NPR3																			
DWP ver7 08Feb11.S3.04.030.1 Open Channel U&V																			

▶ Level Effort
 ■ Remaining Work
 ◆ Milestone
■ Actual Work
 ■ Critical Remaining Work

Activity ID	Activity Name	Original Duration	Remaining Duration	Start	Finish	Total Float	2011											
							Jan	Feb	Mar	Apr	May	Jun	Jul	Aug				
							14	15	16	17	18	19	20	21				
18590	Casting Blockwork Walls for open channel U & V	30	30	01-Mar-11	30-Mar-11	0												
18600	CONSTRUCT OPEN CHANNEL U & V	101	101	16-Mar-11	24-Jun-11	0												
18610	Rockfill Type A for open channel U & V	36	36	16-Mar-11	30-Apr-11	0												
18620	Leveling Stone for open channel U & V	36	36	28-Mar-11	14-May-11	0												
18630	Blockwork wall for open channel U & V	36	36	09-Apr-11	26-May-11	0												
18640	Rockfill Type A behind open channel U & V	36	36	18-Apr-11	03-Jun-11	0												
18650	Geotextile Type A & Filter of open channel U & V	36	36	29-Apr-11	13-Jun-11	0												
18660	Backfill behind open channel U&V	36	36	13-May-11	24-Jun-11	0												
DWP ver7 08Feb11.S3.04.030.2 Reclamation Area																		
18670	Removal of temporary channel and reinstatement	7	7	25-Jun-11	04-Jul-11	0												
18680	Construct 225, 300, 375 & 450 Drainage	50	50	16-Jun-11	13-Aug-11	0												
19210	Construct 300 & 375 half round U-channel	50	50	16-Jun-11	13-Aug-11	0												
19270	Temporary drainage for 1350mm pipe	45	45	06-Apr-11	02-Jun-11	4												
19280	Construct 1350mm pipe to open channel U&V	21	21	09-May-11	02-Jun-11	4												
DWP ver7 08Feb11.S3.04.030.3 Existing Land Area																		
41000	Drainage Works	76	109	13-Dec-10 A	22-Jun-11	7												
VO21-0010	Method statement approved by the Engineer	14	1	09-Nov-10 A	08-Feb-11*	17												
VO21-0050	Apply TTA 2nd	14	14	14-Mar-11	29-Mar-11	7												
DWP ver7 08Feb11.S3.04.030.3.1 In the working area (1350mm to the existing seawall)																		
VO21-1042	Diversion the access in workshop	2	0	01-Feb-11 A	02-Feb-11 A													
VO21-1050	Paving Breaking and Trial Excavation 2nd stage (west)	4	4	10-Feb-11*	14-Feb-11	7												
VO21-1060	Sheet piling, excavation and shoring 2nd stage (west)	12	12	15-Feb-11	28-Feb-11	7												
VO21-1070	construct dia 1350mm pipe 2nd stage (west)	4	4	01-Mar-11	04-Mar-11	15												
VO21-1080	Backfill and reinstatement 2nd stage (west)	10	10	05-Mar-11	16-Mar-11	20												
VO21-1090	Paving Breaking and Trial Excavation 3rd stage (east)	4	4	17-Mar-11	21-Mar-11	20												
VO21-1100	Sheet piling, excavation and shoring 3rd stage (east)	12	12	22-Mar-11	04-Apr-11	20												
VO21-1110	construct dia 1350mm pipe 3rd stage (east)	2	2	06-Apr-11	07-Apr-11	20												
VO21-1120	Backfill and reinstatement 3rd stage (east)	10	10	08-Apr-11	19-Apr-11	20												
DWP ver7 08Feb11.S3.04.030.3.2 TTA 1st at east lane of Oil Street																		
VO21-2010	TTA 1st	1	1	14-Feb-11*	14-Feb-11	0												
VO21-2020	Pavement Breaking and trial excavation	3	3	15-Feb-11	17-Feb-11	16												
VO21-2030	Sheet piling, excavation and shoring	12	12	01-Mar-11	14-Mar-11	7												
VO21-2040	Laying dia 1350mm pipe	3	3	15-Mar-11	17-Mar-11	7												
VO21-2050	Backfill and reinstatement	10	10	18-Mar-11	29-Mar-11	7												
DWP ver7 08Feb11.S3.04.030.3.3 TTA 2nd at west lane of Oil Street																		
VO21-3010	TTA 2nd	2	2	30-Mar-11*	31-Mar-11	7												
VO21-3020	Pavement breaking and trial excavation	4	4	01-Apr-11	06-Apr-11	7												
VO21-3030	Sheet piling, excavation and shoring	12	12	07-Apr-11	20-Apr-11	7												
VO21-3040	Connect dia 1350mm pipe from MH7-T to the proposed pipe	3	3	21-Apr-11	27-Apr-11	7												
VO21-3050	Modify MH7-T	12	12	21-Apr-11	09-May-11	7												
VO21-3060	Backfill existing dia 750mm pipe from MH7-T to MH6-T	6	6	11-May-11	17-May-11	7												
VO21-3070	Construct dia 450mm pipe from MH7-T to MH6-T	6	6	18-May-11	24-May-11	7												
VO21-3080	Backfill the existing dia 750mm pipe from MH6-T to existing outfall	6	6	25-May-11	31-May-11	13												
VO21-3090	Modify MH6-T	12	12	25-May-11	08-Jun-11	7												
VO21-3100	Backfill and reinstatement	12	12	09-Jun-11	22-Jun-11*	7												
DWP ver7 08Feb11.S3.07 PERMANENT RELOCATION OF NAVIGATION LIGHT																		
21700	Permanent relocation navigation light	12	12	26-Jul-11	08-Aug-11	5												

▶ Level Effort
 Remaining Work
 ◆ ◆ Milestone
 Actual Work
 Critical Remaining Work

Activity ID	Activity Name	Original Duration	Start	Finish	Total Float	Quantity	Prod Rate	2011			2012			2013			2014			2015			2016
								J	A	J	J	A	J	J	J	A	J	J	J	A	J	J	J
HY/2009/15 - Works Programme Revision B																							
Commencement of Works																							
CD_5410	Contract Commencement	0d	27-Sep-10 A																				
CD_5789	Commencement of Reclamation Works (120d)	0d	25-Jan-11*		0d																		
Initial Works																							
CD_5560	Site Possession - Portion VII (7), Day 0	0d	27-Sep-10 A																				
PG_5420	Initial Topographic(Ground Condition) Survey	56d	27-Sep-10 A	02-Dec-10 A																			
PG_5675	Contractors Site Office - design submission	11d	27-Sep-10 A	09-Oct-10 A																			
PG_5690	Arrange work boat for transportation	29d	27-Sep-10 A	01-Nov-10 A																			
PG_5695	Arrange work boat/barge for material deliveries	29d	27-Sep-10 A	01-Nov-10 A																			
PG_5500	Appoint Independent Hydrographic Surveyor	15d	27-Sep-10 A	14-Oct-10 A																			
PG_5530	Appoint Independent Surveyor for Condition Survey of Vessels	15d	27-Sep-10 A	14-Oct-10 A																			
PG_3040	Appoint ICE + approval	12d	27-Sep-10 A	29-Oct-10 A																			
PG_3050	Install tilting/settlement monitors	40d	27-Sep-10 A	13-Nov-10 A																			
S6_3020	Demolition of TLW Fireboat Station (TLFBS)	49d	01-Oct-10 A	02-Dec-10 A																			
PG_5680	Contractors Site Office - review and approval	15d	11-Oct-10 A	28-Oct-10 A																			
PG_3730	Condition Survey of the existing vessels	23d	19-Nov-10 A	20-Nov-10 A																			
PG_5685	Contractors Site Office - construction	60d	03-Dec-10 A	17-Dec-10*	66d																		
PG_5460	Structural Condition Survey - POC & RHKYC	28d	17-Dec-10	21-Jan-11	108d																		
Permits and Licenses																							
PG_5430	Preparation and Application of MDN Marine Dept.	3d	27-Sep-10 A	26-Oct-10 A																			
PG_5775	Preparation and Application of FEP to EPD	5d	27-Sep-10 A	26-Oct-10 A																			
PG_5450	Preparation and Application DASO Dumping Permit	3d	01-Oct-10 A	08-Oct-10 A																			
PG_5780	EPD review and approval of FEP	23d	09-Oct-10 A	22-Nov-10 A																			
Submissions: Method Statement and/or Particulars																							
Method Statements/Particulars																							
A1040	Method Statement - Transporting and placing of concrete	1d	17-Dec-10	17-Dec-10	135d																		
A1045	Tidal and underwater concreting proposals in respect of tidal works	1d	17-Dec-10	17-Dec-10	135d																		
A1050	Method statement for watertightness of permanent interface structures	1d	17-Dec-10	17-Dec-10	135d																		

- Remaining Work
- Critical Remaining Work
- Milestone

1 of 53

China State Construction Engineering (Hong Kong) Ltd

Contract No. HY/2009/15 - Central Wan Chai By Pass - Tunnel (Causeway Bay Typhoon Shelter Section)

WORKS PROGRAMME REV. B

Prepared by William Caluza

Date	Revision	Checked	Approved
15-Feb...	Date prepared	ST	KL
	(progress updated to 17 December 2010)		



中國建築工程(香港)有限公司
CHINA STATE CONSTRUCTION ENGINEERING (HONG KONG) LTD.

Activity ID	Activity Name	Original Duration	Start	Finish	Total Float	Quantity	Prod Rate	2011			2012			2013			2014			2015			2016
								J	A	J	J	A	J	J	J	A	J	J	J	A	J	J	J
Major Materials																							
PG_1261	Submit Concrete Mix Particulars	48d	27-Sep-10 A	17-Feb-11	52d																		
PG_1263	Submit Steel Reinforcement Supplier Particulars	24d	17-Dec-10	17-Jan-11	112d																		
PG_1262	Concrete Trial Mix	36d	18-Feb-11	31-Mar-11	52d																		
PG_1264	Submit Structural Steel Particulars	24d	24-Feb-11	23-Mar-11	126d																		
Procurement/Fabrication																							
Fabrication Works																							
FB_1000	Seawall block - design+ shopdrawing- preparation +submission	48d	09-Oct-10 A	04-Dec-10 A																			
FB_1010	Seawall block - design+ shopdrawing- Engrs review and approval	28d	06-Dec-10 A	10-Jan-11 A																			
FB_1020	Seawall block - start fabrication	0d	14-Dec-10 A																				
FB_1060	OHVD Precast Slab - design+ shopdrawing- preparation +submission	48d	09-Oct-12*	04-Dec-12	166d																		
FB_1070	OHVD Precast Slab - design+ shopdrawing- Engrs review and approval	36d	05-Dec-12	18-Jan-13	166d																		
FB_1080	OHVD Precast Slab - start fabrication	0d	23-Jan-13*		203d																		
KD1 - Phase 1 Marine Works Re-Arrangement																							
Submissions																							
PG_1000	Method Statement - Phase 1 Mooring Re-Arrangement - preparation and submission	12d	04-Oct-10 A	21-Oct-10 A																			
PG_1010	Method Statement - Phase 1 Mooring Re-Arrangement: Engineers review and approval	12d	06-Oct-10 A	18-Nov-10 A																			
TDS_1007	Phase 1 Mooring Components - manufacture/delivery to HK	14d	19-Oct-10 A	01-Nov-10 A																			
TDS_1000	Design of Phase 1&2 Mooring Re-arrangements + Components (PS 1.117) - preparation and submission	12d	21-Oct-10 A	11-Nov-10 A																			
TDS_1005	Design of Phase 1&2 Mooring Re-arrangements + Components (PS 1.117) - Engineers review and approval	12d	01-Nov-10 A	17-Nov-10 A																			
Sequence 1																							
CD_5565	Site Possession - Portion VIII (8), Day 0	0d	27-Sep-10 A																				
ST1_5800	Application and Issue of MDN for removal of existing moorings	24d	27-Sep-10 A	27-Oct-10 A																			
ST1_5805	Application and Issue of MDN for dredging works	24d	27-Sep-10 A	26-Oct-10 A																			
ST1_5810	Preparation and submission to EPD DASO Type 1 & 2	12d	27-Sep-10 A	11-Oct-10 A																			
ST1_5815	EPD Issue DASO Permit	28d	12-Oct-10 A	08-Nov-10 A																			
ST1_5795	Hydrographic survey of seabed	4d	18-Oct-10 A	27-Oct-10 A																			
ST1_5850	Removal of existing moorings (PMA)	5d	28-Oct-10 A	02-Nov-10 A																			
ST1_5820	Installation of silt curtain	4d	02-Nov-10 A	05-Nov-10 A																			

- Remaining Work
- Critical Remaining Work
- Milestone

2 of 53

China State Construction Engineering (Hong Kong) Ltd

Contract No. HY/2009/15 - Central Wan Chai By Pass - Tunnel (Causeway Bay Typhoon Shelter Section)

WORKS PROGRAMME REV. B

Prepared by William Caluza

Date	Revision	Checked	Approved
15-Feb...	Date prepared	ST	KL
	(progress updated to 17 December 2010)		



中國建築工程(香港)有限公司
CHINA STATE CONSTRUCTION ENGINEERING (HONG KONG) LTD.

Activity ID	Activity Name	Original Duration	Start	Finish	Total Float	Quantity	Prod Rate	2011			2012			2013			2014			2015			2016
								J	A	J	A	J	A	J	A	J	A	J	A	J	A	J	A
S1_1152	Design submission for temp access shaft	24d	05-Sep-11	06-Oct-11	45d																		
S1_1148	Interface coordination with HY/2009/19 for temp. access shaft	0d	06-Oct-11		45d																		
S26135	Engineer review and approval design submission for temp access shaft	48d	06-Oct-11	01-Dec-11	45d																		
CCT TS1 at Portion 1,2,4,6, and 22																							
CD_5650	Site Possession - Portion XXII (22), Day 0	0d	27-Sep-10 A																				
CD_5535	Site Possession - Portion II (2), Day 28	0d	25-Oct-10 A																				
CD_5555	Site Possession - Portion VI (6), Day 28	0d	25-Oct-10 A																				
S1_2095	Tree Transplanting	50d	22-Dec-10 A	19-Feb-11	78d																		
CD_5530	Site Possession - Portion I (1), Day 129	0d	03-Feb-11*		0d																		
S1_2100	Install/ Construct temp works	24d	18-Feb-11*	17-Mar-11	38d																		
S1_2103	Remove Existing Breakwater (on the landside only)	24d	18-Mar-11	15-Apr-11	38d																		
S1_2180	Installation of Hoarding	16d	09-Apr-11	30-Apr-11*	70d																		
S1_2108	Portion 1,2,6 & 22 - Backfill area with general fill	23d	16-Apr-11	18-May-11	38d																		
S1_5850	Construct temporary access shaft (3mx2m, PS1.140D)	24d	01-Dec-11	31-Dec-11	45d																		
S1_2150	Construction of TS1 Tunnel + bulkhead completed	0d		31-Dec-11	33d																		
S1_5855	Make good temporary access shaft	48d	04-Mar-14	03-May-14	8d																		
EV Adit at Portion 1,2 6, 22																							
Submissions																							
S1_1135	Prepare and submit formwork/falsework design	24d	27-Sep-11	27-Oct-11	33d																		
S1_1140	Engineer review and approval - formwork/falsework design	48d	27-Oct-11	22-Dec-11	33d																		
S1_1145	Prepare and submit method statement	24d	27-Oct-11	24-Nov-11	33d																		
S1_1150	Engineer review and approval on method statement	24d	24-Nov-11	22-Dec-11	33d																		
EV Adit Tunnel Construction at Portion 1,2,6,22																							
S1_5100	EVA Tunnel base slab	8d	22-Dec-11	04-Jan-12	33d	1 bay																	
S1_2160	EVA Tunnel backfilling to ground level	10d	04-Jan-12	16-Jan-12	33d																		
S1_5000	EVA Tunnel wall and roof	0d	04-Jan-12	04-Jan-12	33d	1 bay																	
S1_2220	Completion of Section 1 (Portion 1 & 2)	0d		16-Jan-12	41d																		
EV Adit at Portion 4- Advance Works																							
Submissions																							

- Remaining Work
- Critical Remaining Work
- Milestone

4 of 53

China State Construction Engineering (Hong Kong) Ltd

Contract No. HY/2009/15 - Central Wan Chai By Pass - Tunnel (Causeway Bay Typhoon Shelter Section)

WORKS PROGRAMME REV. B

Prepared by William Caluza

Date	Revision	Checked	Approved
15-Feb...	Date prepared	ST	KL
	(progress updated to 17 December 2010)		



中國建築工程(香港)有限公司
CHINA STATE CONSTRUCTION ENGINEERING (HONG KONG) LTD.

Activity ID	Activity Name	Original Duration	Start	Finish	Total Float	Quantity	Prod Rate	2011			2012			2013			2014			2015			2016	
								J	A	J	J	A	J	J	J	J	J	A	J	A	J	J	A	J
TS2 - Initial Works																								
S2_1085	Initial hydrographic survey (echo sounding)	6d	17-Dec-10	23-Dec-10	328d																			
S2_1090	Detailed survey and record photo	6d	17-Dec-10	23-Dec-10	328d																			
TS2 - Temporary Reclamation																								
Submission Deadline																								
S2_6205	Prepare and Submit Seawall block design for TS2	24d	07-Nov-11	03-Dec-11	47d																			
S2_6219	Prepare and Submit CMC model for temporary reclamation - TS2	24d	07-Nov-11	03-Dec-11	47d																			
S2_6210	Prepare and Submit MS for dredging works at TS2	24d	26-Nov-11	24-Dec-11	7d																			
S2_6215	Prepare and Submit Dredging plan for TS2	24d	26-Nov-11	24-Dec-11	7d																			
S2_6200	Prepare and and submit Silt curtain proposal for TS2 works	18d	01-Dec-11	22-Dec-11	8d																			
S2_6165	Engr review and approval - Seawall block design for TS2	48d	05-Dec-11	04-Feb-12	47d																			
S2_6220	Prepare and Submit MS for temporary reclamation (seawall block & general fill) - TS2	24d	05-Dec-11	04-Jan-12	47d																			
S2_6225	Submit particulars of seawall block	24d	05-Dec-11	04-Jan-12	47d																			
S2_6175	Engr Review and Approval Silt curtain proposal for TS2 works	24d	22-Dec-11	26-Jan-12	8d																			
S2_6155	Engr review and approval MS for dredging works at TS2	24d	24-Dec-11	28-Jan-12	7d																			
S2_6160	Engr review and approval - Dredging plan for TS2	24d	24-Dec-11	28-Jan-12	7d																			
S2_6170	Engr review and approval - MS for temporary reclamation (seawall block & general fill) - TS2	24d	05-Jan-12	04-Feb-12	47d																			
S2_6185	Engr review and approval - particulars of seawall block	24d	05-Jan-12	04-Feb-12	47d																			
S2_6230	Submit particulars of rockfill material	24d	17-Jan-12	17-Feb-12	7d																			
S2_6190	Engr review and approval - particulars of rockfill material	24d	17-Feb-12	16-Mar-12	7d																			
S2_6235	Submit particulars of general fill material	24d	12-Mar-12	13-Apr-12	7d																			
S2_6195	Engr review and approval - particulars of general fill material	24d	13-Apr-12	12-May-12	7d																			
S2_6240	Submit Geotechnical Instrumentation Plan - TS2	24d	13-Jul-12	10-Aug-12	23d																			
S2_6180	Engr review and approval - Geotechnical Instrumentation Plan - TS2	24d	10-Aug-12	07-Sep-12	23d																			
Permits and/or Licenses																								
S2_1111	Apply for DASO Permit- TS2	41d	17-Dec-10	09-Feb-11	272d																			
S2_1116	EPD approval of DASO for TS2	28d	09-Feb-11	09-Mar-11	334d																			
Marine Site Investigation																								
S2_1216	MDN application for marine investigation	12d	23-Sep-11	08-Oct-11	49d																			

- Remaining Work
- Critical Remaining Work
- Milestone

12 of 53

China State Construction Engineering (Hong Kong) Ltd

Contract No. HY/2009/15 - Central Wan Chai By Pass - Tunnel (Causeway Bay Typhoon Shelter Section)

WORKS PROGRAMME REV. B

Prepared by William Caluza

Date	Revision	Checked	Approved
15-Feb...	Date prepared	ST	KL
	(progress updated to 17 December 2010)		



中國建築工程(香港)有限公司
CHINA STATE CONSTRUCTION ENGINEERING (HONG KONG) LTD.

Activity ID	Activity Name	Original Duration	Start	Finish	Total Float	Quantity	Prod Rate	2011			2012			2013			2014			2015			2016	
								J	A	J	A	J	J	J	J	A	J	J	J	J	A	J	J	J
S2_3810	Curtain grout along (soil pre treatment) proposed diaphragm wall	54d	06-Jul-12	29-Aug-12	10d	310 nos	3holes/d/rig, use 2 rigs																	
S2_3830	TS2 - DIAPHRAGM WALL SUMMARY	117d	06-Jul-12	31-Oct-12	11d																			
S2_1122	Site investigation for DW & barettes	54d	06-Jul-12	29-Aug-12	10d	71nos	3d/no, use 4 SI rigs																	
S2_1132	Construct guidewall	21d	06-Jul-12	27-Jul-12	30d	426m	10m/d/crew, use 2 crew																	
S2_1121	Set up bentonite silo/plants and equipments	24d	06-Jul-12	03-Aug-12	7d																			
S2_1137	Construct diaphragm wall	71d	03-Aug-12	13-Oct-12	8d	59 nos	3 days / no, use 3 rigs																	
S2_1157	Diaphragm Wall & Barette pile tests (interface coring & integrity test)	48d	13-Sep-12	31-Oct-12	11d																			
S2_1142	Construct barette piles	12d	13-Oct-12	25-Oct-12	11d	12 nos	3 days / no, use 3 rigs																	
TS2 - ELS Works																								
Submission Deadline																								
S2_6600	Submit design for dewatering system	24d	05-Apr-12	08-May-12	51d																			
S2_6544	Prepare and submit CMC model for ELS at TS2	24d	13-Apr-12	11-May-12	7d																			
S2_6650	Engineers review and approval - design for dewatering system	48d	08-May-12	06-Jul-12	51d																			
S2_6530	Submit ELS design TS2 (4 month for GEO comments&resolution)	24d	12-May-12	09-Jun-12	7d																			
S2_6545	Submit MS for ELS at TS2 (4 month for GEO comments&resolution)	24d	12-May-12	09-Jun-12	7d																			
S2_6532	Engineers review and approval - ELS design TS2	24d	11-Jun-12	10-Jul-12	7d																			
S2_6547	Engineers review and approval - MS for ELS at TS2	24d	11-Jun-12	10-Jul-12	7d																			
S2_6500	GEO review and approval - ELS design TS2 (4 months for GEO comments&resolution)	96d	11-Jul-12	02-Nov-12	7d																			
S2_6505	GEO review and approval - MS for ELS at TS2 (4 month for GEO comments&resolution)	96d	11-Jul-12	02-Nov-12	7d																			
S2_6535	Submit instrumentation particulars (inclinometer/ strain gauges)	24d	13-Jul-12	10-Aug-12	23d																			
S2_6540	Submit MS for instrumentation	24d	13-Jul-12	10-Aug-12	23d																			
S2_6520	Engineers review and approval - instrumentation particulars (inclinometer/ strain gauges)	24d	10-Aug-12	07-Sep-12	23d																			
S2_6525	Engineers review and approval - MS for instrumentation	24d	10-Aug-12	07-Sep-12	23d																			
S2_6550	Submit welding procedures & welders test certificates for ELS (welding)	24d	07-Sep-12	06-Oct-12	8d																			
S2_6555	Submit particulars of ELS materials (structural steel)	24d	07-Sep-12	06-Oct-12	8d																			
S2_6510	Engineers review and approval - particulars of ELS materials (structural steel)	24d	08-Oct-12	05-Nov-12	8d																			
S2_6515	Engineers review and approval - welding procedures & welders test certificates for ELS (welding)	24d	08-Oct-12	05-Nov-12	8d																			
S2_6610	Submit pumping test report	1d	02-Nov-12	02-Nov-12	7d																			
Excavation and Lateral Support Works																								

- Remaining Work
- Critical Remaining Work
- Milestone

14 of 53

China State Construction Engineering (Hong Kong) Ltd

Contract No. HY/2009/15 - Central Wan Chai By Pass - Tunnel (Causeway Bay Typhoon Shelter Section)

WORKS PROGRAMME REV. B

Prepared by William Caluza

Date	Revision	Checked	Approved
15-Feb...	Date prepared	ST	KL
	(progress updated to 17 December 2010)		



中國建築工程(香港)有限公司
CHINA STATE CONSTRUCTION ENGINEERING (HONG KONG) LTD.

Activity ID	Activity Name	Original Duration	Start	Finish	Total Float	Quantity	Prod Rate	2011			2012			2013			2014			2015			2016
								J	A	J	J	A	J	J	J	A	J	J	A	J	J	A	J
TS4 - Permits and/or Licenses																							
S2_5935	Apply for DASO Permit for Type 3	24d	12-Nov-10 A	19-Nov-10 A																			
S2_5942	Field Trials	24d	17-Dec-10	17-Jan-11	8d																		
S2_5945	EPD approval of DASO Permit for type 3	24d	17-Dec-10	17-Jan-11	8d																		
TS4 - Initial Works																							
CD_5655	Site Possession - Portion XXIII (23), Day 0	0d	27-Sep-10 A																				
CD_5600	Site Possession - Portion XIVA (14A), Day 0	0d	27-Sep-10 A																				
CD_5605	Site Possession - Portion XIVB (14B), Day 0	0d	27-Sep-10 A																				
S2_7005	Initial hydrographic survey (echo sounding)	6d	27-Sep-10 A	04-Oct-10 A																			
S2_7010	Detailed survey and record photo- existing seawall	6d	05-Oct-10 A	30-Oct-10 A																			
S2_7015	CEDD Agreement - Detailed survey and record photo- existing seawall	6d	17-Dec-10	23-Dec-10	837d																		
S2_7055	Submit reinstatement plan prior to demolition (45d prior to start of works)	6d	17-Dec-10	23-Dec-10	837d																		
TS4 - Marine Site Investigation																							
S2_7000	MDN application for marine investigation	12d	22-Nov-10 A	25-Nov-10 A																			
S2_7020	Issue of MDN for marine investigation works	18d	26-Nov-10 A	17-Dec-10	22d																		
S2_7025	Marine site investigation - CPPT and vibrocore works at TS4	10d	17-Dec-10	30-Dec-10	22d																		
S2_7030	Marine site investigation - submissions of reports	4d	31-Dec-10	05-Jan-11	40d																		
TS4 - Re-provision of Floating Pontoon																							
Submission Deadline																							
PG_1180	Method Statement - Re-provision of Temp. Floating Pontoon: preparation and submission	24d	09-Oct-10 A	12-Nov-10 A																			
S2_7035	Prepare and Submit MS for construction of floating pontoon	24d	13-Nov-10 A	20-Nov-10 A																			
S2_7050	Engr Review and Approval- design of floating pontoon	24d	20-Nov-10 A	26-Nov-10 A																			
S2_7045	Engr review and approval MS for construction of floating pontoon	24d	21-Nov-10 A	08-Jan-11	9d																		
S2_7040	Prepare and and submit design of floating pontoon	18d	17-Dec-10	10-Jan-11	8d																		
Re-Provision of Floating Pontoon																							
S2_5930	MDN Application for for dredging works	24d	23-Oct-10 A	26-Oct-10 A																			
PG_1190	Method Statement - Re-provision of Temp. Floating Pontoon: Engineers review and approval	18d	13-Nov-10 A	27-Nov-10 A																			
S2_5940	Issue of MDN	14d	27-Nov-10 A	10-Dec-10 A																			
S2_5950	Install silt curtain	2d	13-Dec-10 A	13-Dec-10 A																			

- Remaining Work
- Critical Remaining Work
- Milestone

17 of 53

China State Construction Engineering (Hong Kong) Ltd

Contract No. HY/2009/15 - Central Wan Chai By Pass - Tunnel (Causeway Bay Typhoon Shelter Section)

WORKS PROGRAMME REV. B

Prepared by William Caluza

Date	Revision	Checked	Approved
15-Feb...	Date prepared	ST	KL
	(progress updated to 17 December 2010)		



中國建築工程(香港)有限公司
CHINA STATE CONSTRUCTION ENGINEERING (HONG KONG) LTD.

Activity ID	Activity Name	Original Duration	Start	Finish	Total Float	Quantity	Prod Rate	2011			2012			2013			2014			2015			2016
								J	A	J	A	J	A	J	A	J	A	J	A	J	A	J	A
S2_7130	Engr review and approval MS for dredging works at TS4	24d	25-Nov-10 A	06-Dec-10 A																			
S2_7135	Engr review and approval - Dredging plan for TS4	24d	25-Nov-10 A	06-Dec-10 A																			
S2_7090	Prepare and Submit Seawall block design for TS4	24d	02-Dec-10 A	24-Dec-10	66d																		
S2_7105	Prepare and Submit MS for dredging works at TS4	24d	17-Dec-10	17-Jan-11	8d																		
S2_7100	Engr review and approval - Seawall block design for TS4	24d	28-Dec-10	25-Jan-11	66d																		
S2_7095	Prepare and Submit CMC model for temporary reclamation - TS4	24d	13-Jan-11	12-Feb-11	5d																		
S2_7115	Prepare and Submit MS for temporary reclamation (seawall block & general fill) - TS4	24d	14-Feb-11	12-Mar-11	5d																		
S2_7140	Engr review and approval - MS for temporary reclamation (seawall block & general fill) - TS4	24d	14-Mar-11	11-Apr-11	5d																		
S2_7120	Submit Geotechnical Instrumentation Plan - TS4	24d	13-Aug-11	09-Sep-11	4d																		
S2_7150	Engr review and approval - Geotechnical Instrumentation Plan - TS4	24d	10-Sep-11	11-Oct-11	4d																		
Temporary Reclamation																							
S2_3955	TS4- dredge South side Type 3 sediments (Area 1)	26d	21-Jan-11*	18-Feb-11	6d	2,800 m3	600m3/trip @ 4d/trip																
S2_3970	TS4 - dredge South side, Type 1 & Type 2 sediments (Area 1&2)	14d	19-Feb-11	04-Mar-11	6d	14,778 m3	1,850 m3/d																
S2_3960	TS4 - place rockfill South side (Area 1), underneath temporary seawall below seabed	1d	05-Mar-11	05-Mar-11	6d	330 m3	1,500 m3/d																
S2_3972	TS4 - dredge East side, Type 1 (Area 3)	8d	05-Mar-11	12-Mar-11	6d	14,880 m3	1,850 m3/d																
S2_3962	TS4 - place levelling stone South side (Area 1 & 2)	14d	13-Mar-11	26-Mar-11	6d																		
S2_4150	Demolish existing jetty	6d	13-Mar-11	18-Mar-11	47d																		
S2_3967	TS4 - place rockfill at East side	2d	27-Mar-11	28-Mar-11	6d	1,600m3	1,500 m3/d																
S26125	TS4 - Place levelling stone at East side	14d	29-Mar-11	11-Apr-11	6d																		
S2_3965	TS4 - place seawall block to +4 at South side	11d	12-Apr-11	22-Apr-11	6d	700	50 nos/d																
S26130	TS4 - place seawall block to +4 at East side, leave opening at north east corner to allow barge for filling inside	6d	23-Apr-11	28-Apr-11	6d	393	50 nos/d																
S2_3973	TS4 - dredge North side(Area 4) and remaining areas (middle area)	4d	29-Apr-11	03-May-11	6d	7,390 m3	1,850 m3/d																
S2_3980	TS4 - place rockfill North side underneath temporary seawall below seabed	2d	03-May-11	04-May-11	6d	121 m3	1,500 m3/d																
S2_3982	TS4 - place levelling stone North side	14d	05-May-11	18-May-11	6d																		
S2_3990	TS4 - place seawall blocks to +4 North side but leave temporary opening at NE corner to allow barge for filling	8d	19-May-11	26-May-11	6d	459	50 nos/d																
S26120	TS4 - General fill to +2 within the seawall	17d	27-May-11	12-Jun-11	6d	51,500	3,000 m3/d																
S26115	TS4 - place seawall blocks to +4 at the temporary opening at NE corner	4d	13-Jun-11	16-Jun-11	6d	200	50 nos/d																
S2_4000	TS4 - Remaining General fill to +4 within the seawall	11d	17-Jun-11	27-Jun-11	6d	33,000	3,000 m3/d																
TS4 - Diaphragm Wall																							

- Remaining Work
- Critical Remaining Work
- ◆ Milestone

19 of 53

China State Construction Engineering (Hong Kong) Ltd

Contract No. HY/2009/15 - Central Wan Chai By Pass - Tunnel (Causeway Bay Typhoon Shelter Section)

WORKS PROGRAMME REV. B

Prepared by William Caluza

Date	Revision	Checked	Approved
15-Feb...	Date prepared	ST	KL
	(progress updated to 17 December 2010)		



中國建築工程(香港)有限公司
CHINA STATE CONSTRUCTION ENGINEERING (HONG KONG) LTD.

Activity ID	Activity Name	Original Duration	Start	Finish	Total Float	Quantity	Prod Rate	2011			2012			2013			2014			2015			2016
								J	A	J	A	J	J	J	A	J	A	J	J	A	A	J	J
Submission Deadline																							
S2_7190	Submit ELS design TS4 (4 month for GEO comments&resolution)	12d	21-Feb-11	05-Mar-11	4d																		
S2_7192	Engineers review and approval - ELS design TS4	18d	07-Mar-11	26-Mar-11	4d																		
S2_7200	GEO review and approval - ELS design TS4 (4 months for GEO comments&resolution)	96d	28-Mar-11	26-Jul-11	4d																		
S2_7160	Submit Diaphragm Wall Trench Stability and Guide Wall Design	24d	04-Apr-11	06-May-11	10d																		
S2_7165	Prepare and submit CMC model for diaphragm wall construction - TS4	24d	04-Apr-11	06-May-11	10d																		
S2_7170	Engineers review and approval -Diaphragm Wall Trench Stability and Guide Wall Design	48d	07-May-11	05-Jul-11	10d																		
S2_7175	Submit MS for diaphragm wall construction - TS4	24d	07-May-11	04-Jun-11	10d																		
S2_7180	Engineers review and approval - MS for diaphragm wall construction - TS4	24d	07-Jun-11	05-Jul-11	10d																		
Diaphragm Wall																							
S2_4020	Curtain grout along proposed diaphragm wall	21d	28-Jun-11	22-Jul-11	10d	324 holes	3holes/d/rig, use 2 rigs																
S2_4040	DIAPHRAGM WALL SUMMARY	117d	28-Jun-11	15-Nov-11	10d																		
S2_4022	Install king posts	32d	28-Jun-11	04-Aug-11	95d	16 nos	3nos/week/rig																
S2_4033	Site investigation	54d	28-Jun-11	30-Aug-11	4d	54 nos	3d/no/rig, use 3 rigs																
S2_4031	Set up bentonite silo/plants and equipments	24d	28-Jun-11	26-Jul-11	4d																		
S2_4025	Install guide wall	33d	06-Jul-11	12-Aug-11	10d	324m	10m/d																
S2_4035	Diaphragm wall construction	81d	27-Jul-11	01-Nov-11	4d	54 panels	6d/panel @ 3d cycle																
S2_4037	Install shear pins on diaphragm wall	82d	16-Aug-11	22-Nov-11	4d	136 nos	5nos/week/rig																
S2_4043	Diaphragm Wall Pile test	48d	19-Sep-11	15-Nov-11	10d																		
S2_4046	Carry out contact/fissure grouting	21d	29-Oct-11	22-Nov-11	126d	216 holes	10holes/d																
TS4 - ELS Works & Soft Excavation																							
Submission Deadline																							
S2_7185	Prepare and submit CMC model for ELS at TS4	24d	26-May-11	23-Jun-11	4d																		
S2_7195	Submit MS for ELS at TS4 (4 month for GEO comments&resolution)	12d	24-Jun-11	08-Jul-11	4d																		
S5_7197	Engineers review and approval - MS for ELS at TS4	18d	09-Jul-11	29-Jul-11	4d																		
S2_7205	GEO review and approval - MS for ELS at TS4 (4 month for GEO comments&resolution)	96d	30-Jul-11	22-Nov-11	4d																		
S2_7210	Submit design for dewatering system	24d	06-Aug-11	02-Sep-11	4d																		
S2_7215	Engineers review and approval - design for dewatering system	48d	03-Sep-11	01-Nov-11	4d																		
S2_7220	Submit pumping test report	1d	22-Nov-11	22-Nov-11	4d																		

- Remaining Work
- Critical Remaining Work
- Milestone

20 of 53

China State Construction Engineering (Hong Kong) Ltd

Contract No. HY/2009/15 - Central Wan Chai By Pass - Tunnel (Causeway Bay Typhoon Shelter Section)

WORKS PROGRAMME REV. B

Prepared by William Caluza

Date	Revision	Checked	Approved
15-Feb...	Date prepared	ST	KL
	(progress updated to 17 December 2010)		



中國建築工程(香港)有限公司
CHINA STATE CONSTRUCTION ENGINEERING (HONG KONG) LTD.

Activity ID	Activity Name	Original Duration	Start	Finish	Total Float	Quantity	Prod Rate	2011				2012				2013				2014				2015				2016
								J	A	J	A	J	A	J	A	J	A	J	A	J	A	J	A	J	A	J	A	J
TS4 - ELS Works & Soft Excavation																												
S2_4038	Install dewatering wells and piezometers	48d	28-Jun-11	23-Aug-11	61d			█	Install dewatering wells and piezometers																			
S2_4041	Install inclinometers inside D-wall	36d	12-Oct-11	22-Nov-11	4d			█	Install inclinometers inside D-wall																			
S2_4045	Carry out pumping tests	18d	02-Nov-11	22-Nov-11	4d			█	Carry out pumping tests																			
S2_4081	1st Layer - Soft Excavation	14d	23-Nov-11	08-Dec-11	4d	15,258m3	2,000m3/d	█	1st Layer - Soft Excavation																			
S2_4080	TS4- ELS SUMMARY (EXCEPT ROCK EXCAVATION)	154d	23-Nov-11	24-Apr-12	4d				TS4- ELS SUMMARY (EXCEPT ROCK EXCAVATION)																			
S2_4082	1st Layer - install lateral support	14d	28-Nov-11	13-Dec-11	4d			█	1st Layer - install lateral support																			
S2_4083	Install vibrating wire strain gauge	6d	02-Dec-11	08-Dec-11	4d			█	Install vibrating wire strain gauge																			
S2_4084	2nd Layer - Soft Excavation	14d	09-Dec-11	24-Dec-11	4d	15,258m3	2,000m3/d	█	2nd Layer - Soft Excavation																			
S2_4085	2nd Layer - install lateral support	14d	14-Dec-11	31-Dec-11	4d			█	2nd Layer - install lateral support																			
S2_4086	3rd Layer - Soft Excavation	14d	03-Jan-12	18-Jan-12	4d	15,258m3	2,000m3/d	█	3rd Layer - Soft Excavation																			
S2_4087	3rd Layer - install lateral support	14d	07-Jan-12	26-Jan-12	4d			█	3rd Layer - install lateral support																			
S2_4088	4th Layer - Soft Excavation	14d	27-Jan-12	11-Feb-12	4d	15,258m3	1,800m3/d	█	4th Layer - Soft Excavation																			
S2_4089	4th Layer - install lateral support	14d	01-Feb-12	16-Feb-12	4d			█	4th Layer - install lateral support																			
S2_4091	5th Layer - Soft Excavation	14d	17-Feb-12	03-Mar-12	4d	15,258m3	1,800m3/d	█	5th Layer - Soft Excavation																			
S2_4092	5th Layer - install lateral support	14d	22-Feb-12	08-Mar-12	4d			█	5th Layer - install lateral support																			
S2_4093	6th Layer - Soft Excavation	14d	09-Mar-12	24-Mar-12	4d	20,343m3	1,500m3/d	█	6th Layer - Soft Excavation																			
S2_4094	6th Layer - install lateral support	14d	14-Mar-12	29-Mar-12	4d			█	6th Layer - install lateral support																			
S2_4095	Special ELS (pipe pile) prior to installation of rock anchor at SE corner of TS4	36d	26-Mar-12	11-May-12	57d			█	Special ELS (pipe pile) prior to installation of rock anchor at SE corner of TS4																			
S2_4096	7th Layer - Soft Excavation	14d	30-Mar-12	19-Apr-12	4d	12,714m3	1,500m3/d	█	7th Layer - Soft Excavation																			
S2_4098	7th Layer - install lateral support	14d	05-Apr-12	24-Apr-12	4d			█	7th Layer - install lateral support																			
TS4 - Rock Excavation																												
S2_4180	Rock excavation west side (area near tunnel portal) (no rock anchor to be installed)	130d	25-Apr-12	27-Sep-12	4d	52,000 m3	400 m3/d	█	Rock excavation west side (area near tunnel portal) (no rock anchor to be installed)																			
S2_4185	Install tie back anchor to D- Walls (TS4+ area on east side)	63d	12-May-12	27-Jul-12	57d	63 nos	3nos/week/rig	█	Install tie back anchor to D- Walls (TS4+ area on east side)																			
S2_4190	Rock excavation east side (remainder)	65d	28-Sep-12	15-Dec-12	4d	26,000 m3	400 m3/d	█	Rock excavation east side (remainder)																			
TS4 - AS LOGISTICS AREA FOR MINED TUNNELING WORKS																												
S2_4210	DURATION FOR USE OF TS4 AS ACCESS FOR MINED TUNNEL WORKS	208d	01-Jun-12	07-Feb-13	16d			█	DURATION FOR USE OF TS4 AS ACCESS FOR MINED TUNNEL WORKS																			
S2_4215	Commencement of MT works at SR8	0d	01-Jun-12		21d			◆	Commencement of MT works at SR8																			
S2_4225	Commencement of MT works at E/B	0d	30-Jul-12		22d			◆	Commencement of MT works at E/B																			

- █ Remaining Work
- █ Critical Remaining Work
- ◆ Milestone

21 of 53

China State Construction Engineering (Hong Kong) Ltd

Contract No. HY/2009/15 - Central Wan Chai By Pass - Tunnel (Causeway Bay Typhoon Shelter Section)

WORKS PROGRAMME REV. B

Prepared by William Caluza

Date	Revision	Checked	Approved
15-Feb...	Date prepared	ST	KL
	(progress updated to 17 December 2010)		



中國建築工程(香港)有限公司
CHINA STATE CONSTRUCTION ENGINEERING (HONG KONG) LTD.

Activity ID	Activity Name	Original Duration	Start	Finish	Total Float	Quantity	Prod Rate	2011			2012			2013			2014			2015			2016
								J	A	J	A	J	J	J	J	A	J	A	J	J	J	A	J
Additional Temporary Reclamation (TS4+ Area)																							
CD_5770	Engineer Instruction Section 7B (480d)	0d	20-Jan-12		49d																		
S7B_2065	Commencement of ME4 (subject to excision 480d)	0d	20-Jan-12		39d																		
S7B_2070	TS4+ Area, Dredge Type 2 sediments	18d	20-Jan-12	13-Feb-12	39d	31,000 m3	1,850 m3/d																
S7B_2075	TS4+ Area, Place rockfill	8d	14-Feb-12	22-Feb-12	39d	10,898 m3	1,300 m3/d																
S7B_2080	TS4+ Area, Place levelling stone	24d	23-Feb-12	21-Mar-12	39d																		
S7B_2085	TS4+ Area, Place seawall block	22d	22-Mar-12	20-Apr-12	39d	1,087 nos	50no/d																
S7B_2090	TS4+ Area, General fill to +4	15d	21-Apr-12	09-May-12	39d	46,100 m3	4000 m3/d																
Additional Temporary Reclamation (TZ6)																							
S7B_2095	TZ6 Area, Dredge Type 3 sediments	55d	10-May-12	16-Jul-12	77d	8,000 m3	600m3/trip @ 4d/trip																
S7B_2100	TZ6 Area, Place rockfill	5d	17-Jul-12	21-Jul-12	77d	6,792 m3	1,300 m3/d																
S7B_2105	TZ6 Area, Place levelling stone	18d	23-Jul-12	11-Aug-12	77d																		
S7B_2107	TZ6 Area, Place seawall block	14d	13-Aug-12	28-Aug-12	77d	684	50no/d																
S7B_2109	TZ6 Area, General fill to +4	13d	29-Aug-12	12-Sep-12	77d	36,600	3000 m3/d																
ME4 - Diaphragm Wall																							
Submission Deadline																							
S7B_2110	Submit Diaphragm Wall Trench Stability and Guide Wall Design	24d	17-Feb-12	15-Mar-12	45d																		
S7B_2115	Prepare and submit CMC model for diaphragm wall construction - ME4	24d	09-Mar-12	10-Apr-12	39d																		
S7B_2120	Engineers review and approval -Diaphragm Wall Trench Stability and Guide Wall Design	48d	16-Mar-12	16-May-12	45d																		
S7B_2125	Submit MS for diaphragm wall construction - ME4	24d	11-Apr-12	09-May-12	39d																		
S7B_2130	Engineers review and approval - MS for diaphragm wall construction - ME4	24d	10-May-12	07-Jun-12	39d																		
Diaphragm Wall																							
S7B_5330	Curtain grout along proposed diaphragm wall	24d	10-May-12	07-Jun-12	39d																		
S7B_3200	ME4 D-WALL SUMMARY	160d	10-May-12	16-Oct-12	94d																		
S7B_2145	Site investigation for diaphragm wall	46d	10-May-12	05-Jul-12	39d	46 nos	3d/no., use 3 rigs																
S7B_2138	Install king posts	24d	10-May-12	07-Jun-12	103d	12 nos	3 per week																
S7B_2140	Construct guide wall	21d	17-May-12	11-Jun-12	45d																		
S7B_2150	Diaphragm wall construction- TS4+	42d	08-Jun-12	28-Jul-12	39d	28 nos	6d/panel @ 3d cycle																
S7B_2152	Install shear pins at D Wall in TS4+	38d	28-Jun-12	11-Aug-12	159d	64 nos	5nos/week/rig																

- Remaining Work
- Critical Remaining Work
- Milestone

24 of 53

China State Construction Engineering (Hong Kong) Ltd

Contract No. HY/2009/15 - Central Wan Chai By Pass - Tunnel (Causeway Bay Typhoon Shelter Section)

WORKS PROGRAMME REV. B

Prepared by William Caluza

Date	Revision	Checked	Approved
15-Feb...	Date prepared	ST	KL
	(progress updated to 17 December 2010)		



中國建築工程(香港)有限公司
CHINA STATE CONSTRUCTION ENGINEERING (HONG KONG) LTD.

Activity ID	Activity Name	Original Duration	Start	Finish	Total Float	Quantity	Prod Rate	2011			2012			2013			2014			2015			2016
								J	A	J	A	J	J	J	J	J	A	J	J	J	J	A	J
Submission Deadline																							
S2_7255	Prepare and submit CMC model for removal of temp reclamation and TZ4, TZ6 construction	24d	30-Apr-13	29-May-13	31d																	■ Prepare and submit CMC model for removal of temp rec	
S2_7250	Submit design of bulkhead at TZ4, TZ6	24d	02-May-13	30-May-13	34d																	■ Submit design of bulkhead at TZ4, TZ6	
S2_7265	Submit MS for removal of temp reclamation and ME4 construction	24d	30-May-13	27-Jun-13	31d																	■ Submit MS for removal of temp reclamation and ME4 cc	
S2_7260	Engineers review and approval - design of bulkhead at TZ4, TZ6	48d	31-May-13	27-Jul-13	34d																	■ Engineers review and approval - design of bulkhead a	
S2_7270	Engineers review and approval - MS for removal of temp reclamation and ME4 construction	24d	28-Jun-13	26-Jul-13	31d																	■ Engineers review and approval - MS for removal of ter	
With ME4, Removal of Temporary Reclamation																							
S7B_6155	DURATION OF TEMP. RECLAMATION TS4 (1029)	950d	12-Apr-11	16-Nov-13	5d																	DURATION OF TEMP. RECLAMATION TS4 (
S7B_3240	REMOVAL OF TEMP. RECLAMATION SUMMARY	115d	25-Jul-13	16-Nov-13	5d																	REMOVAL OF TEMP. RECLAMATION SUMM	
S7B_2510	Removal of ELS inside cofferdam	54d	25-Jul-13	26-Sep-13	4d	9 layers	6d/layer															■ Removal of ELS inside cofferdam	
S7B_2515	Remove general fill (between D Wall & seawall block)	7d	27-Jul-13	03-Aug-13	31d	9,574																■ Remove general fill (between D Wall & seawall block)	
S7B_2520	Remove seawall block	24d	29-Jul-13	24-Aug-13	31d	1,576 nos																■ Remove seawall block	
S7B_2525	Install seawall block for TZ4, TZ6	18d	29-Jul-13	17-Aug-13	34d	880 nos																■ Install seawall block for TZ4, TZ6	
S7B_2530	General fill for TZ4, TZ6	3d	19-Aug-13	21-Aug-13	34d	7,774 m3																■ General fill for TZ4, TZ6	
S7B_2535	Saw cut diaphragm wall (nos.)	36d	27-Sep-13	09-Nov-13	4d	70 panels	2d/panel/1machine															■ Saw cut diaphragm wall (nos.)	
S7B_2540	Reinstate vertical seawall	24d	27-Sep-13	26-Oct-13	22d																	■ Reinstate vertical seawall	
S7B_2545	Reinstate seabed	22d	23-Oct-13	16-Nov-13	4d																	■ Reinstate seabed	
S7B_3300	Completion of Section 7B (ME4)	0d		16-Nov-13	5d																	◆ Completion of Section 7B (ME4)	
S2_4160	Completion of Section 2 (With ME4 option)	0d		16-Nov-13	5d																	◆ Completion of Section 2 (With ME4 option)	
Re-Provision of Permanent Jetty & Floating Pontoon																							
CDS_1020	Permanent Re-provisioned Floating Pontoon - design preparation and submission	72d	16-Mar-13	15-Jun-13	53d																	■ Permanent Re-provisioned Floating Pontoon - design pr	
CDS_1000	Permanent Re-provisioned Jetty - design preparation and submission	72d	18-Apr-13	15-Jul-13	53d																	■ Permanent Re-provisioned Jetty - design preparation a	
CDS_1030	Design of Permanent Re-provisioned Floating Pontoon - Engineers review and approval	24d	17-Jun-13	15-Jul-13	53d																	■ Design of Permanent Re-provisioned Floating Pontoon	
S6_5240	Design Submission to BD -Permanent Jetty	24d	17-Jun-13	15-Jul-13	53d																	■ Design Submission to BD -Permanent Jetty	
CDS_1010	Design of Permanent Re-provisioned Jetty - Engineers review and approval	48d	16-Jul-13	09-Sep-13	53d																	■ Design of Permanent Re-provisioned Jetty - Engine	
CDS_1035	Permanent Re-provisioned Floating Pontoon - manufacture/delivery	48d	16-Jul-13	09-Sep-13	53d																	■ Permanent Re-provisioned Floating Pontoon - man	
S6_5245	BD Review and Approval -Permanent Jetty	48d	16-Jul-13	09-Sep-13	53d																	■ BD Review and Approval -Permanent Jetty	
PG_1200	Method Statement - Permanent re-provision of Jetty: preparation and submission	24d	23-Jul-13	19-Aug-13	53d																	■ Method Statement - Permanent re-provision of Jetty	
PG_1220	Method Statement - Permanent re-provision of Floating Pontoon: preparation and submission	24d	23-Jul-13	19-Aug-13	53d																	■ Method Statement - Permanent re-provision of Floa	

- Remaining Work
- Critical Remaining Work
- Milestone

28 of 53

China State Construction Engineering (Hong Kong) Ltd

Contract No. HY/2009/15 - Central Wan Chai By Pass - Tunnel (Causeway Bay Typhoon Shelter Section)

WORKS PROGRAMME REV. B

Prepared by William Caluza

Date	Revision	Checked	Approved
15-Feb...	Date prepared	ST	KL
	(progress updated to 17 December 2010)		



中國建築工程(香港)有限公司
CHINA STATE CONSTRUCTION ENGINEERING (HONG KONG) LTD.

Activity ID	Activity Name	Original Duration	Start	Finish	Total Float	Quantity	Prod Rate	2011			2012			2013			2014			2015			2016
								J	A	J	J	A	J	J	J	A	J	J	J	A	J	J	J
TPCWAE- Permits and/or Licenses																							
S6_7245	Apply for DASO Permit for Type 1/2	24d	27-Sep-10 A	26-Oct-10 A																			
S6_7255	EPD approval of DASO Permit for type 1/2	28d	27-Oct-10 A	27-Nov-10 A																			
Drainage Diversion works along Hung Hing Road (Portion 19)																							
PG_5440	Apply Excavation Permit for drainage works in HH Road	90d	15-Oct-10 A	12-Jan-11	0d																		
PG_5805	TTA Submission for CSHK works in Hung Hing Rd	28d	08-Dec-10 A	17-Dec-10	20d																		
CD_5630	Site Possession - Portion XIX (19), Day 73	0d	10-Dec-10 A																				
S6_3003	TTA Implementation for drainage works along Hung hing Road	6d	13-Jan-11	19-Jan-11	0d																		
S6_3005	Trial pit & verification of any existing utilities at Hung Hing Road	12d	20-Jan-11	02-Feb-11	0d																		
S6_3010	DRAINAGE AT HH RD - SUMMARY	138d	07-Feb-11	24-Jun-11	0d																		
S6_3012	Stage 1- short pipe	12d	07-Feb-11	19-Feb-11	0d	225DN, 12m length																	
S6_3017	Stage 2- excavation, pipelaying, MH, backfill	24d	21-Feb-11	19-Mar-11	0d	225DN, 40m length, 1 MH	1.5 wk excav, 0.5 week pipelaying, 2																
S6_3025	Stage 3- excavation, pipelaying, MH, backfill	24d	21-Mar-11	18-Apr-11	0d	225DN, 40m length, 2 MH	1.5 wk excav, 0.5 week pipelaying, 2																
S6_3030	Stage 4- excavation, pipelaying, MH, backfill	24d	19-Apr-11	21-May-11	0d	225DN, 60m length, 2 MH	1.5 wk excav, 0.5 week pipelaying, 2																
S6_3035	Stage 5- excavation, pipelaying, MH, backfill	28d	23-May-11	24-Jun-11	0d	300/375DN, 70m length, 2	2 wk excav, 1 week pipelaying, 2																
TPCWAE - Initial Works																							
CD_5635	Site Possession - Portion XXA (20A), Day 0	0d	27-Sep-10 A																				
CD_5640	Site Possession - Portion XXB (20B), Day 0	0d	27-Sep-10 A																				
CD_5645	Site Possession - Portion XXI (21), Day 0	0d	27-Sep-10 A																				
S6_8195	Initial hydrographic survey (echo sounding)	6d	01-Nov-10 A	13-Nov-10 A																			
S6_8200	Detailed survey and record photo- existing seawall	6d	14-Nov-10 A	04-Dec-10 A																			
S6_8205	CEDD Agreement - Detailed survey and record photo- existing seawall	6d	17-Dec-10	23-Dec-10	184d																		
S6_8203	Instrumentation at PCWA	24d	17-Dec-10	17-Jan-11	148d	12	???																
S6_8210	Submit reinstatement plan prior to demolition (45d prior to start of works)	6d	24-Dec-10	03-Jan-11	184d																		
TPCWAE- Marine Site Investigation																							
S6_7225	MDN application for marine investigation	12d	04-Nov-10 A	11-Nov-10 A																			
S6_7230	Issue of MDN for marine investigation works	18d	12-Nov-10 A	29-Nov-10 A																			
S6_7235	Marine site investigation - CPPT and vibrocore works at TPCWAE	10d	30-Nov-10 A	04-Dec-10 A																			
S6_7240	Marine site investigation - submissions of reports	4d	05-Dec-10 A	17-Dec-10	19d																		

- Remaining Work
- Critical Remaining Work
- Milestone

40 of 53

China State Construction Engineering (Hong Kong) Ltd

Contract No. HY/2009/15 - Central Wan Chai By Pass - Tunnel (Causeway Bay Typhoon Shelter Section)

WORKS PROGRAMME REV. B

Prepared by William Caluza

Date	Revision	Checked	Approved
15-Feb...	Date prepared	ST	KL
	(progress updated to 17 December 2010)		



中國建築工程(香港)有限公司
CHINA STATE CONSTRUCTION ENGINEERING (HONG KONG) LTD.

Activity ID	Activity Name	Original Duration	Start	Finish	Total Float	Quantity	Prod Rate	2011			2012			2013			2014			2015			2016
								J	A	J	J	J	A	J	J	J	A	J	J	J	A	J	J
TPCWAE - Temporary Reclamation																							
Submission Deadline																							
S6_7880	Prepare and Submit MS for dredging works at TPCWAE	24d	29-Oct-10 A	17-Dec-10 A																			
S6_7870	Prepare and and submit Silt curtain proposal for TPCWAE works	18d	05-Nov-10 A	25-Nov-10 A																			
S6_7885	Prepare and Submit Dredging plan for TPCWAE	24d	16-Nov-10 A	24-Nov-10 A																			
S6_7845	Engr review and approval - Dredging plan for TPCWAE	24d	24-Nov-10 A	06-Dec-10 A																			
S6_7860	Engr Review and Approval Silt curtain proposal for TPCWAE works	24d	26-Nov-10 A	23-Dec-10	7d																		
S6_7840	Engr review and approval MS for dredging works at TPCWAE	18d	17-Dec-10 A	03-Jan-11	1d																		
S6_7875	Prepare and Submit Seawall block design for TPCWAE	6d	17-Dec-10	23-Dec-10	0d																		
S6_7900	Prepare and Submit CMC model for temporary reclamation - TPCWAE	6d	17-Dec-10	23-Dec-10	0d																		
S6_7850	Engr review and approval - Seawall block design for TPCWAE	24d	22-Dec-10	21-Jan-11	0d																		
S6_7890	Prepare and Submit MS for temporary reclamation (seawall block & general fill) - TPCWAE	6d	22-Dec-10	30-Dec-10	0d																		
S6_7855	Engr review and approval - MS for temporary reclamation (seawall block & general fill) - TPCWAE	18d	31-Dec-10	21-Jan-11	0d																		
S6_7895	Submit Geotechnical Instrumentation Plan - TPCWAE	24d	04-Jul-11	01-Aug-11	85d																		
S6_7865	Engr review and approval - Geotechnical Instrumentation Plan - TPCWAE	24d	01-Aug-11	29-Aug-11	85d																		
Temporary Reclamation																							
S6_7095	TPCWAE- dredge West side	14d	08-Dec-10 A	10-Jan-11	1d	22,200 m3	1,850 m3/d																
S6_7125	TPCWAE - dredge North side and remaining areas (middle area)	15d	11-Jan-11	25-Jan-11	1d	22,200 m3	1,850 m3/d																
S6_7130	TPCWAE - place rockfill North side	6d	22-Jan-11*	27-Jan-11	0d	7,848 m3	1,500 m3/d																
S6_7105	TPCWAE - place rockfill West side	6d	28-Jan-11	02-Feb-11	29d	7,848 m3	1,500 m3/d																
S6_7107	TPCWAE - Erect sea wall block for survey platform	1d	20-Feb-11*	20-Feb-11	128d																		
S6_7110	TPCWAE - place levelling stone West side	14d	07-Mar-11*	20-Mar-11	0d																		
S6_7120	TPCWAE - place seawall block to +4 at West side	11d	21-Mar-11	31-Mar-11	100d	530 nos	50 nos/d																
S6_7135	TPCWAE - place levelling stone North side	14d	21-Mar-11	03-Apr-11	97d																		
S6_7140	TPCWAE - place seawall blocks to +4 North side but leave temporary opening to allow barge for filling	11d	04-Apr-11	14-Apr-11	97d	530 nos	50 nos/d																
S6_8455	TPCWAE - General fill to +2 within the seawall	24d	15-Apr-11	09-May-11	97d	71,205m3	3,000 m3/d																
S6_8450	TPCWAE - place seawall blocks to +4 at the temporary opening	4d	10-May-11	13-May-11	97d	200	50 nos/d																
S6_7145	TPCWAE - Remaining General fill to +4 within the seawall (construct twin steel pipe 3mdia at TZ5 for future access)	7d	14-May-11	20-May-11	97d	20,000	3,000 m3/d																
TPCWAE - Diaphragm Wall																							

- Remaining Work
- Critical Remaining Work
- Milestone

41 of 53

China State Construction Engineering (Hong Kong) Ltd

Contract No. HY/2009/15 - Central Wan Chai By Pass - Tunnel (Causeway Bay Typhoon Shelter Section)

WORKS PROGRAMME REV. B

Prepared by William Caluza

Date	Revision	Checked	Approved
15-Feb...	Date prepared	ST	KL
	(progress updated to 17 December 2010)		



中國建築工程(香港)有限公司
CHINA STATE CONSTRUCTION ENGINEERING (HONG KONG) LTD.

Activity ID	Activity Name	Original Duration	Start	Finish	Total Float	Quantity	Prod Rate	2011			2012			2013			2014			2015			2016
								J	A	J	A	J	J	J	A	J	A	J	J	A	A	J	J
Submission Deadline																							
S6_7940	Submit ELS design TPCWAE (4 month for GEO comments&resolution)	12d	11-Jan-11	25-Jan-11	81d																		
S6_7942	Engineers review and approval - ELS design TPCWAE	18d	25-Jan-11	18-Feb-11	81d																		
S6_7930	GEO review and approval - ELS design TPCWAE - (4 months for GEO comments&resolution)	96d	18-Feb-11	18-Jun-11	81d																		
S6_7915	Submit Diaphragm Wall Trench Stability and Guide Wall Design	24d	25-Feb-11	25-Mar-11	87d																		
S6_7925	Prepare and submit CMC model for diaphragm wall construction - TPCWAE	24d	18-Mar-11	16-Apr-11	81d																		
S6_7905	Engineers review and approval -Diaphragm Wall Trench Stability and Guide Wall Design	48d	25-Mar-11	27-May-11	87d																		
S6_7920	Submit MS for diaphragm wall construction - TPCWAE	24d	16-Apr-11	20-May-11	81d																		
S6_7910	Engineers review and approval - MS for diaphragm wall construction - TPCWAE	24d	20-May-11	18-Jun-11	81d																		
Diaphragm Wall																							
S6_7260	Curtain grout along proposed diaphragm wall	20d	20-May-11	14-Jun-11	87d	308 holes	16 holes/d																
S6_7270	DIAPHRAGM WALL SUMMARY	114d	20-May-11	06-Oct-11	105d																		
S6_8275	Install king posts	48d	20-May-11	18-Jul-11	157d	24 nos	3nos/week/rig																
S6_8425	Site investigation	52d	20-May-11	22-Jul-11	81d	52 nos	3d/no/rig																
S6_8423	Set up bentonite silo/plants and equipments	24d	20-May-11	18-Jun-11	81d																		
S6_7265	Install guide wall	31d	27-May-11	05-Jul-11	87d	308m	10m/d																
S6_8265	Diaphragm wall construction	78d	18-Jun-11	20-Sep-11	81d	52 panels	6d/panel @ 3d cycle																
S6_8270	Install shear pins on diaphragm wall	63d	28-Jul-11	13-Oct-11	85d	156 nos	5nos/week/rig																
S6_7275	Diaphragm Wall Pile test	48d	08-Aug-11	06-Oct-11	105d																		
S6_8295	Carry out contact/fissure grouting	31d	03-Sep-11	13-Oct-11	204d	312 holes	10holes/d																
TPCWAE- ELS Works & Soft Excavation																							
Submission Deadline																							
S6_7965	Prepare and submit CMC model for ELS at TPCWAE	24d	14-Apr-11	18-May-11	81d																		
S6_7945	Submit MS for ELS at TPCWAE - (4 month for GEO comments&resolution)	12d	18-May-11	01-Jun-11	81d																		
S6_7947	Engineers review and approval - MS for ELS at TPCWAE	18d	01-Jun-11	23-Jun-11	81d																		
S6_7935	GEO review and approval - MS for ELS at TPCWAE - (4 month for GEO comments&resolution)	96d	23-Jun-11	18-Oct-11	81d																		
S6_7950	Submit design for dewatering system	24d	25-Jun-11	25-Jul-11	81d																		
S6_7960	Engineers review and approval - design for dewatering system	48d	25-Jul-11	20-Sep-11	81d																		
S6_7955	Submit pumping test report	1d	17-Oct-11	18-Oct-11	81d																		

- Remaining Work
- Critical Remaining Work
- Milestone

42 of 53

China State Construction Engineering (Hong Kong) Ltd

Contract No. HY/2009/15 - Central Wan Chai By Pass - Tunnel (Causeway Bay Typhoon Shelter Section)

WORKS PROGRAMME REV. B

Prepared by William Caluza

Date	Revision	Checked	Approved
15-Feb...	Date prepared	ST	KL
	(progress updated to 17 December 2010)		



中國建築工程(香港)有限公司
CHINA STATE CONSTRUCTION ENGINEERING (HONG KONG) LTD.

Activity ID	Activity Name	Original Duration	Start	Finish	Total Float	Quantity	Prod Rate	2011				2012				2013				2014				2015				2016
								J	A	J	A	J	J	J	A	J	A	J	J	J	A	J	J	J	A	J	J	J
ELS Works																												
S6_8280	Install dewatering wells and piezometers	48d	20-May-11	18-Jul-11	135d																							
S6_8285	Install inclinometers inside D-wall	36d	29-Aug-11	13-Oct-11	85d																							
S6_7280	Carry out pumping tests	21d	20-Sep-11	17-Oct-11	81d																							
S6_7285	1st Layer - Soft Excavation	14d	18-Oct-11	03-Nov-11	81d	21,576m3	2,000m3/d																					
S6_8470	TPCWAE - ELS SUMMARY (EXCEPT ROCK EXCAVATION)	141d	18-Oct-11	07-Mar-12	101d																							
S6_7290	1st Layer - install lateral support	14d	22-Oct-11	08-Nov-11	81d																							
S6_7295	Install vibrating wire strain gauge	6d	27-Oct-11	03-Nov-11	81d																							
S6_7300	2nd Layer - Soft Excavation	14d	03-Nov-11	19-Nov-11	81d	26,970m3	2,000m3/d																					
S6_7305	2nd Layer - install lateral support	14d	08-Nov-11	24-Nov-11	81d																							
S6_7310	3rd Layer - Soft Excavation	14d	24-Nov-11	10-Dec-11	81d	12,406m3	2,000m3/d																					
S6_7315	3rd Layer - install lateral support	14d	29-Nov-11	15-Dec-11	81d																							
S6_7320	4th Layer - Soft Excavation	14d	15-Dec-11	04-Jan-12	81d	17,261m3	1,800m3/d																					
S6_7325	4th Layer - install lateral support	14d	20-Dec-11	09-Jan-12	81d																							
S6_7330	5th Layer - Soft Excavation	14d	09-Jan-12	28-Jan-12	81d	18,879m3	1,800m3/d																					
S6_7335	5th Layer - install lateral support	14d	13-Jan-12	02-Feb-12	81d																							
S6_7340	6th Layer - Soft Excavation	25d	02-Feb-12	02-Mar-12	81d	37,758m3	1,500m3/d																					
S6_7345	6th Layer - install lateral support	25d	07-Feb-12	07-Mar-12	81d																							
S6_8290	Install tie back anchor to D- Walls (area on east side, near mined tunnel)	45d	12-Mar-12	09-May-12	186d	67 nos	3nos/week/rig																					
S6_8292	Install tie back anchor to D- Walls (area on west side, remainder)	53d	09-May-12	13-Jul-12	186d	53 nos	3nos/week/rig																					
TPCWAE - ROCK EXCAVATION																												
S6_7360	Rock excavation west side (area near tunnel portal) (no rock anchor to be installed)	109d	12-Mar-12	26-Jul-12	81d	43,600 m3	400 m3/d																					
S6_7365	Rock excavation east side (remainder)	57d	26-Jul-12	03-Oct-12	175d	22,700 m3	400 m3/d																					
TPCWAE - AS LOGISTICS AREA FOR MINED TUNNELING WORKS																												
S6_7370	DURATION FOR USE OF TPCWAE AS ACCESS FOR MINED TUNNEL WORKS	341d	12-May-12	18-Apr-13	98d																							
S6_7376	Commencement of MT works at SR8	0d	12-May-12		189d																							
S6_7372	Commencement of MT works at E/B	0d	07-Jul-12		423d																							
S6_7374	Commencement of MT works at W/B	0d	07-Jul-12		325d																							
TPCWAE- CCT RC Structure																												

- Remaining Work
- Critical Remaining Work
- Milestone

43 of 53

China State Construction Engineering (Hong Kong) Ltd

Contract No. HY/2009/15 - Central Wan Chai By Pass - Tunnel (Causeway Bay Typhoon Shelter Section)

WORKS PROGRAMME REV. B

Prepared by William Caluza

Date	Revision	Checked	Approved
15-Feb...	Date prepared	ST	KL
	(progress updated to 17 December 2010)		



中國建築工程(香港)有限公司
CHINA STATE CONSTRUCTION ENGINEERING (HONG KONG) LTD.

Activity ID	Activity Name	Original Duration	Start	Finish	Total Float	Quantity	Prod Rate	2011			2012			2013			2014			2015			2016
								J	A	J	A	J	J	J	J	J	A	J	J	J	J	J	J
Submission Deadline																							
S6_7980	Submit formwork and falsework design for CCT - TPCWAE	24d	01-Nov-12	28-Nov-12	80d																		■ Submit formwork and falsework design for CCT - TPCWAE
S6_7990	Prepare and submit CMC model for CCT-TPCWAE construction	24d	01-Nov-12	28-Nov-12	80d																		■ Prepare and submit CMC model for CCT-TPCWAE construction
S6_7970	Engineers review and approval - formwork and falsework design for CCT - TPCWAE -	48d	29-Nov-12	26-Jan-13	80d																		■ Engineers review and approval - formwork and falsework design
S6_7985	Submit MS for CCT-TPCWAE construction	24d	29-Nov-12	28-Dec-12	80d																		■ Submit MS for CCT-TPCWAE construction
S6_7975	Engineers review and approval MS for CCT-TPCWAE construction	24d	29-Dec-12	26-Jan-13	80d																		■ Engineers review and approval MS for CCT-TPCWAE construction
TPCWAE - CCT (Half- West Side)																							
S6_7375	TPCWAE - Construct tunnel base slab	25d	28-Jan-13	28-Feb-13	80d	10 bays	5d/bay/formwork																■ TPCWAE - Construct tunnel base slab
S6_8475	TPCWAE - CCT SUMMARY (EAST SIDE)	68d	28-Jan-13	05-Apr-13	98d																		TPCWAE - CCT SUMMARY (EAST SIDE)
S6_7380	TPCWAE - Construct tunnel wall & roof slab	40d	14-Feb-13	05-Apr-13	80d	10 bays	8d/bay/formwork																■ TPCWAE - Construct tunnel wall & roof slab
TPCWAE - CCT (Remaining Half - near Mined Tunnel)																							
S6_7385	TPCWAE Construct tunnel base slab	23d	19-Mar-13	18-Apr-13	80d	9 bays	5d/bay/formwork																■ TPCWAE Construct tunnel base slab
S6_8480	TPCWAE - CCT SUMMARY (WEST SIDE)	80d	19-Mar-13	06-Jun-13	96d																		TPCWAE - CCT SUMMARY (WEST SIDE)
S6_7390	TPCWAE Construct tunnel wall & roof slab (incl. mucking out access at TZ5 area)	36d	06-Apr-13	20-May-13	80d	9 bays	8d/bay/formwork																■ TPCWAE Construct tunnel wall & roof slab (incl. mucking
S6_7392	TPCWAE - external waterproofing on top of completed CCT box (incl. screeding)	24d	27-Apr-13	27-May-13	83d																		■ TPCWAE - external waterproofing on top of completed C
S6_8410	TPCWAE - backfilling to sea bed level	30d	02-May-13	06-Jun-13	80d	89,850m3	3000m3/d																■ TPCWAE - backfilling to sea bed level
TPCWAE - Removal of Temporary Reclamation																							
Submission Deadline																							
S6_8190	Prepare and submit CMC model for removal of temp reclamation and TZ5 construction	24d	31-Jan-13	02-Mar-13	88d																		■ Prepare and submit CMC model for removal of temp reclamation
S6_8180	Submit design of bulkhead at TZ5	24d	01-Feb-13	04-Mar-13	101d																		■ Submit design of bulkhead at TZ5
S6_8185	Submit MS for removal of temp reclamation	24d	04-Mar-13	03-Apr-13	88d																		■ Submit MS for removal of temp reclamation
S6_8170	Engineers review and approval - design of bulkhead at TZ5	48d	05-Mar-13	04-May-13	101d																		■ Engineers review and approval - design of bulkhead at TZ
S6_8175	Engineers review and approval - MS for removal of temp reclamation	24d	05-Apr-13	03-May-13	88d																		■ Engineers review and approval - MS for removal of temp re
Removal of Temporary Reclamation & Form TZ5																							
S6_7510	DURATION OF TEMP. RECLAMATION TPCWAE (1003D)	894d	20-Feb-11	02-Aug-13	97d																		DURATION OF TEMP. RECLAMATION TPCWAE (1
S6_4550	Drive box type sheet pile SW corner of TPCWAE (to form TZ5)	36d	18-Mar-13	03-May-13	88d																		■ Drive box type sheet pile SW corner of TPCWAE (to form
S6_7490	REMOVAL OF TEMP. RECLAMATION SUMMARY	93d	02-May-13	02-Aug-13	97d																		REMOVAL OF TEMP. RECLAMATION SUMMARY
S6_7830	Removal of ELS inside cofferdam	36d	02-May-13	14-Jun-13	80d	6 layers	6d/layer																■ Removal of ELS inside cofferdam
S6_7515	Remove general fill (between D Wall & seawall block)	6d	04-May-13	10-May-13	88d	16,726 m3	3,000 m3/d																■ Remove general fill (between D Wall & seawall block)

- Remaining Work
- Critical Remaining Work
- Milestone

44 of 53

China State Construction Engineering (Hong Kong) Ltd

Contract No. HY/2009/15 - Central Wan Chai By Pass - Tunnel (Causeway Bay Typhoon Shelter Section)

WORKS PROGRAMME REV. B

Prepared by William Caluza

Date	Revision	Checked	Approved
15-Feb...	Date prepared	ST	KL
	(progress updated		
	to 17 December 2010)		



中國建築工程(香港)有限公司
CHINA STATE CONSTRUCTION ENGINEERING (HONG KONG) LTD.

Activity ID	Activity Name	Original Duration	Start	Finish	Total Float	Quantity	Prod Rate	2011				2012				2013				2014				2015				2016
								J	A	J	A	J	A	J	A	J	A	J	A	J	A	J	A	J	A	J	A	J
Removal of Temporary Reclamation																												
S6_9500	DURATION OF TEMP. RECLAMATION TZ5 (1668D)	1599d	20-Feb-11	07-Jul-15	118d																				DURATION O			
S6_9095	DURATION OF TEMP. RECLAMATION TPCWAW (616D)	676d	31-Aug-13	07-Jul-15	118d																				DURATION O			
S6_9090	REMOVAL OF TEMP. RECLAMATION SUMMARY	81d	18-Apr-15	07-Jul-15	118d																				REMOVAL O			
S6_9140	Removal of ELS inside cofferdam	36d	18-Apr-15	01-Jun-15	6d	6 layers	6d/layer																		■ Removal of ELS			
S6_9100	Remove general fill (between D Wall & seawall block)	8d	21-Apr-15	29-Apr-15	6d	23,086 m3	3,000 m3/d																		■ Remove general			
S6_9105	Remove seawall block	9d	22-Apr-15	02-May-15	6d	541 nos	64nos/d																		■ Remove seawall			
S6_9107	Remove box type sheet pile & struts (at south east side)	24d	04-May-15	01-Jun-15	6d																				■ Remove box ty			
S6_9120	Saw cut diaphragm wall (nos.)	33d	22-May-15	02-Jul-15	6d	49 panels	2d/panel/rig																		■ Saw cut diapr			
S6_9125	Start reinstate vertical seawall at Portion 11	0d	22-May-15		6d																				◆ Start reinstate w			
S26185	Remove mass concrete block at PCWA	6d	02-Jun-15	08-Jun-15	121d																				■ Remove mass			
S6_9130	Reinstate seabed	22d	10-Jun-15	07-Jul-15	98d																				■ Reinstate sea			
S6_9135	Completion of Section 5	0d		02-Nov-15	0d																				◆ Compl			
TPCWAW - OHVD / Cable Trough																												
S6_9085	TPCWAW - Cable Trough (access through temp. opening at Portion 19)	120d	22-May-15*	15-Oct-15	86d																				■ TPCWA			
S6_9080	TPCWAW - OHVD Slab (access through temp. opening at Portion 19)	120d	18-Aug-15*	11-Jan-16	14d	172 panels	7 panels/d																		■ TP			
Works in Wan Chai PCWA (Portion 11)																												
Interface with Other Contractor - WDII(2)																												
S4_2740	Bulkhead completed by WDII/2	0d		04-May-14	8d																				◆ Bulkhead completed by WDII/2			
S4_2780	132kV cable diverted by WDII/2	0d		04-May-14	8d																				◆ 132kV cable diverted by WDII/2			
S4_2790	Temporary outfall for Culvert O completed by WDII/2	0d		04-May-14	8d																				◆ Temporary outfall for Culvert O compl			
Initial Works & Utilities Works																												
CD_5580	Site Possession - Portion XI (11), Day 1316	0d	05-May-14		8d																				◆ Site Possession - Portion XI (11), Day			
CD_5585	Site Possession - Portion XII (12), Day 1316	0d	05-May-14*		0d																				◆ Site Possession - Portion XII (12), Day			
S4_2720	Remove existing rock mound	24d	05-May-14	03-Jun-14	6d																				■ Remove existing rock mound			
S4_2701	Commencement of works at Portion 11	0d	05-May-14		6d																				◆ Commencement of works at Portion 1			
S4_2750	Carry out Site Investigation for BW1/BW2	6d	05-May-14	12-May-14	6d	2 nos																			■ Carry out Site Investigation for BW1/B			
S4_2800	Install instrumentation (GSM, Incl. , Piezometer, or Ext.)	24d	05-May-14	03-Jun-14	36d	2 nos	6d/no																		■ Install instrumentation (GSM, Incl. , P			
S4_2810	Installation of Hoarding	24d	05-May-14	03-Jun-14	36d																				■ Installation of Hoarding			

- Remaining Work
- Critical Remaining Work
- Milestone

50 of 53

China State Construction Engineering (Hong Kong) Ltd

Contract No. HY/2009/15 - Central Wan Chai By Pass - Tunnel (Causeway Bay Typhoon Shelter Section)

WORKS PROGRAMME REV. B

Prepared by William Caluza

Date	Revision	Checked	Approved
15-Feb...	Date prepared	ST	KL
	(progress updated		
	to 17 December 2010)		



中國建築工程(香港)有限公司
CHINA STATE CONSTRUCTION ENGINEERING (HONG KONG) LTD.

Activity ID	Activity Name	Original Duration	Start	Finish	Total Float	Quantity	Prod Rate	2011			2012			2013			2014			2015			2016
								J	A	J	J	A	J	J	J	A	J	J	J	A	J	J	J
S4_2755	BW1/BW2 Engineers confirmation of provisional Barrettes	0d		12-May-14	6d																	◆ BW1/BW2 Engineers confirmation of	
S4_2700	Existing drainage pipe/manholes to be temp. supported	12d	19-May-14	31-May-14	21d																	■ Existing drainage pipe/manholes to b	
S4_2730	Existing watermain to be temp. supported	12d	28-May-14	11-Jun-14	21d																	■ Existing watermain to be temp. supp	
S4_2710	Existing LV cable to be temp. supported	12d	07-Jun-14	20-Jun-14	21d																	■ Existing LV cable to be temp. supp	
Reinstatement of Seawall (After Completion of TPCWAW)																							
S4_2770	Reinstatement of vertical seawall	24d	22-May-15	19-Jun-15	6d																	■ Reinstatement	
S4_2775	Backfill utilities and reinstate pavement at Portion 11	11d	10-Jun-15	23-Jun-15	6d																	■ Backfill utilities	
S4_2785	Complete Section 4	0d		01-Jul-15	0d																	◆ Complete Sec	
Interface works with other Contracts																							
S6_5278	Handover Bulk Head at CCT/EV Adit at East V. Adit to CWB(IEC)	0d	27-Feb-12*		0d																	◆ Handover Bulk Head at CCT/EV Adit at East V. Adit to CWB(IEC)	
S6_5279	CWB(IEC) Provide access to CWB(T1) TS1/TS2 Area from East Section of CWB Tunnel	0d	07-Aug-13*		0d																	◆ CWB(IEC) Provide access to CWB(T1) TS1/TS2 Are	
S6_5282	Handover TZ2/TZ3 to CWB(T2)	0d	22-Nov-13*		0d																	◆ Handover TZ2/TZ3 to CWB(T2)	
S6_5283	Handover TZ4/TZ6 to CWB(T2)	0d	22-Nov-13*		0d																	◆ Handover TZ4/TZ6 to CWB(T2)	
S6_5275	Provide access to CWB (RW) Contractor- TS1 & TS2	0d	15-May-14*		0d																	◆ Provide access to CWB (RW) Contra	
S6_5276	Provide access to CWB (TCSS) Contractor - TS1 & TS2	0d	15-May-14*		0d																	◆ Provide access to CWB (TCSS) Cont	
S6_5277	Tree Transplanting to CWB (CI) Contract, start date to be re-confirmed	48d	15-May-14*	11-Jul-14	0d																	■ Tree Transplanting to CWB (CI) C	
S6_5280	Provide access to CWB (RW) Contractor- TS4, TPCWA, Mined Tunnel	0d	02-Jul-15*		0d																	◆ Provide acces	
S6_5281	Provide access to CWB (TCSS) Contractor- TS4, TPCWA, Mined Tunnel	0d	02-Jul-15*		0d																	◆ Provide acces	
Stage and Section Completion																							
KD_5660	KD1- Achievement of Stage 1, (67d)	0d		04-Dec-10 A																		◆ KD1- Achievement of Stage 1, (67d)	
KD_5805	KD2 - Achievement of Stage 2, (142d)	0d		15-Feb-11*	0d																	◆ KD2 - Achievement of Stage 2, (142d)	
KD_5710	KD3 - Achievement of Stage 3, (493d)	0d		01-Feb-12*	0d																	◆ KD3 - Achievement of Stage 3, (493d)	
KD_5715	KD4 - Achievement of Stage 4, (517d)	0d		25-Feb-12*	0d																	◆ KD4 - Achievement of Stage 4, (517d)	
KD_5725	KD6 - Completion of Section 1, (517d)	0d		25-Feb-12*	0d																	◆ KD6 - Completion of Section 1, (517d)	
KD_5720	KD5 - Achievement of Stage 5, (1152d)	0d		21-Nov-13*	0d																	◆ KD5 - Achievement of Stage 5, (1152d)	
KD_5730	KD7 - Completion of Section 2, (1152d)	0d		21-Nov-13*	0d																	◆ KD7 - Completion of Section 2, (1152d)	
KD_5755	KD12 - Completion of Section 7A, (1152d)	0d		21-Nov-13*	0d																	◆ KD12 - Completion of Section 7A, (1152d)	
KD_5760	KD13 - Completion of Section 7B, (1152d)	0d		21-Nov-13*	0d																	◆ KD13 - Completion of Section 7B, (1152d)	
KD_5735	KD8 - Completion of Section 3, (1326d)	0d		14-May-14*	0d																	◆ KD8 - Completion of Section 3, (1326d)	

- Remaining Work
- Critical Remaining Work
- ◆ Milestone

51 of 53

China State Construction Engineering (Hong Kong) Ltd

Contract No. HY/2009/15 - Central Wan Chai By Pass - Tunnel (Causeway Bay Typhoon Shelter Section)

WORKS PROGRAMME REV. B





Prepared by William Caluza

Date	Revision	Checked	Approved
15-Feb...	Date prepared	ST	KL
	(progress updated to 17 December 2010)		



中國建築工程(香港)有限公司
CHINA STATE CONSTRUCTION ENGINEERING (HONG KONG) LTD.

Activity ID	Activity Name	Original Duration	Start	Finish	Total Float	Quantity	Prod Rate	2011				2012				2013				2014				2015				2016					
								J	A	J	A	J	A	J	A	J	A	J	A	J	A	J	A	J	A	J	A	J					
CD_5795	Portion Handover - Portion XXI (21), KD11 +28	0d		24-Feb-16*	0d																												

 Remaining Work
 Critical Remaining Work
  Milestone

53 of 53

China State Construction Engineering (Hong Kong) Ltd

Contract No. HY/2009/15 - Central Wan Chai By Pass - Tunnel (Causeway Bay Typhoon Shelter Section)

WORKS PROGRAMME REV. B

Prepared by William Caluza			
Date	Revision	Checked	Approved
15-Feb...	Date prepared	ST	KL
	(progress updated to 17 December 2010)		



中國建築工程(香港)有限公司

CHINA STATE CONSTRUCTION ENGINEERING (HONG KONG) LTD.

